

DAQ M Series

NI USB-621x User Manual

Bus-Powered M Series USB Devices

[Français](#) [Deutsch](#) [日本語](#) [한국어](#) [简体中文](#)

ni.com/manuals

Worldwide Technical Support and Product Information

ni.com

National Instruments Corporate Headquarters

11500 North Mopac Expressway Austin, Texas 78759-3504 USA Tel: 512 683 0100

Worldwide Offices

Australia 1800 300 800, Austria 43 662 457990-0, Belgium 32 (0) 2 757 0020, Brazil 55 11 3262 3599,
Canada 800 433 3488, China 86 21 5050 9800, Czech Republic 420 224 235 774, Denmark 45 45 76 26 00,
Finland 358 (0) 9 725 72511, France 01 57 66 24 24, Germany 49 89 7413130, India 91 80 41190000,
Israel 972 3 6393737, Italy 39 02 41309277, Japan 0120-527196, Korea 82 02 3451 3400,
Lebanon 961 (0) 1 33 28 28, Malaysia 1800 887710, Mexico 01 800 010 0793, Netherlands 31 (0) 348 433 466,
New Zealand 0800 553 322, Norway 47 (0) 66 90 76 60, Poland 48 22 328 90 10, Portugal 351 210 311 210,
Russia 7 495 783 6851, Singapore 1800 226 5886, Slovenia 386 3 425 42 00, South Africa 27 0 11 805 8197,
Spain 34 91 640 0085, Sweden 46 (0) 8 587 895 00, Switzerland 41 56 2005151, Taiwan 886 02 2377 2222,
Thailand 662 278 6777, Turkey 90 212 279 3031, United Kingdom 44 (0) 1635 523545

For further support information, refer to the *Technical Support and Professional Services* appendix. To comment on National Instruments documentation, refer to the National Instruments Web site at ni.com/info and enter the info code `feedback`.

Important Information

Warranty

The NI USB-6210, NI USB-6211, NI USB-6212, NI USB-6215, NI USB-6216, and NI USB-6218 are warranted against defects in materials and workmanship for a period of one year from the date of shipment, as evidenced by receipts or other documentation. National Instruments will, at its option, repair or replace equipment that proves to be defective during the warranty period. This warranty includes parts and labor.

The media on which you receive National Instruments software are warranted not to fail to execute programming instructions, due to defects in materials and workmanship, for a period of 90 days from date of shipment, as evidenced by receipts or other documentation. National Instruments will, at its option, repair or replace software media that do not execute programming instructions if National Instruments receives notice of such defects during the warranty period. National Instruments does not warrant that the operation of the software shall be uninterrupted or error free.

A Return Material Authorization (RMA) number must be obtained from the factory and clearly marked on the outside of the package before any equipment will be accepted for warranty work. National Instruments will pay the shipping costs of returning to the owner parts which are covered by warranty.

National Instruments believes that the information in this document is accurate. The document has been carefully reviewed for technical accuracy. In the event that technical or typographical errors exist, National Instruments reserves the right to make changes to subsequent editions of this document without prior notice to holders of this edition. The reader should consult National Instruments if errors are suspected. In no event shall National Instruments be liable for any damages arising out of or related to this document or the information contained in it.

EXCEPT AS SPECIFIED HEREIN, NATIONAL INSTRUMENTS MAKES NO WARRANTIES, EXPRESS OR IMPLIED, AND SPECIFICALLY DISCLAIMS ANY WARRANTY OF MERCHANTABILITY OR FITNESS FOR A PARTICULAR PURPOSE. CUSTOMER'S RIGHT TO RECOVER DAMAGES CAUSED BY FAULT OR NEGLIGENCE ON THE PART OF NATIONAL INSTRUMENTS SHALL BE LIMITED TO THE AMOUNT THEREOF PAID BY THE CUSTOMER. NATIONAL INSTRUMENTS WILL NOT BE LIABLE FOR DAMAGES RESULTING FROM LOSS OF DATA, PROFITS, USE OF PRODUCTS, OR INCIDENTAL OR CONSEQUENTIAL DAMAGES, EVEN IF ADVISED OF THE POSSIBILITY THEREOF. This limitation of the liability of National Instruments will apply regardless of the form of action, whether in contract or tort, including negligence. Any action against National Instruments must be brought within one year after the cause of action accrues. National Instruments shall not be liable for any delay in performance due to causes beyond its reasonable control. The warranty provided herein does not cover damages, defects, malfunctions, or service failures caused by owner's failure to follow the National Instruments installation, operation, or maintenance instructions; owner's modification of the product; owner's abuse, misuse, or negligent acts; and power failure or surges, fire, flood, accident, actions of third parties, or other events outside reasonable control.

Copyright

Under the copyright laws, this publication may not be reproduced or transmitted in any form, electronic or mechanical, including photocopying, recording, storing in an information retrieval system, or translating, in whole or in part, without the prior written consent of National Instruments Corporation.

National Instruments respects the intellectual property of others, and we ask our users to do the same. NI software is protected by copyright and other intellectual property laws. Where NI software may be used to reproduce software or other materials belonging to others, you may use NI software only to reproduce materials that you may reproduce in accordance with the terms of any applicable license or other legal restriction.

Trademarks

National Instruments, NI, ni.com, and LabVIEW are trademarks of National Instruments Corporation. Refer to the *Terms of Use* section on ni.com/legal for more information about National Instruments trademarks.

Other product and company names mentioned herein are trademarks or trade names of their respective companies.

Members of the National Instruments Alliance Partner Program are business entities independent from National Instruments and have no agency, partnership, or joint-venture relationship with National Instruments.

Patents

For patents covering National Instruments products/technology, refer to the appropriate location: **Help»Patents** in your software, the `patents.txt` file on your media, or the *National Instruments Patent Notice* at ni.com/patents.

WARNING REGARDING USE OF NATIONAL INSTRUMENTS PRODUCTS

(1) NATIONAL INSTRUMENTS PRODUCTS ARE NOT DESIGNED WITH COMPONENTS AND TESTING FOR A LEVEL OF RELIABILITY SUITABLE FOR USE IN OR IN CONNECTION WITH SURGICAL IMPLANTS OR AS CRITICAL COMPONENTS IN ANY LIFE SUPPORT SYSTEMS WHOSE FAILURE TO PERFORM CAN REASONABLY BE EXPECTED TO CAUSE SIGNIFICANT INJURY TO A HUMAN.

(2) IN ANY APPLICATION, INCLUDING THE ABOVE, RELIABILITY OF OPERATION OF THE SOFTWARE PRODUCTS CAN BE IMPAIRED BY ADVERSE FACTORS, INCLUDING BUT NOT LIMITED TO FLUCTUATIONS IN ELECTRICAL POWER SUPPLY, COMPUTER HARDWARE MALFUNCTIONS, COMPUTER OPERATING SYSTEM SOFTWARE FITNESS, FITNESS OF COMPILERS AND DEVELOPMENT SOFTWARE USED TO DEVELOP AN APPLICATION, INSTALLATION ERRORS, SOFTWARE AND HARDWARE COMPATIBILITY PROBLEMS, MALFUNCTIONS OR FAILURES OF ELECTRONIC MONITORING OR CONTROL DEVICES, TRANSIENT FAILURES OF ELECTRONIC SYSTEMS (HARDWARE AND/OR SOFTWARE), UNANTICIPATED USES OR MISUSES, OR ERRORS ON THE PART OF THE USER OR APPLICATIONS DESIGNER (ADVERSE FACTORS SUCH AS THESE ARE HEREAFTER COLLECTIVELY TERMED "SYSTEM FAILURES"). ANY APPLICATION WHERE A SYSTEM FAILURE WOULD CREATE A RISK OF HARM TO PROPERTY OR PERSONS (INCLUDING THE RISK OF BODILY INJURY AND DEATH) SHOULD NOT BE RELIANT SOLELY UPON ONE FORM OF ELECTRONIC SYSTEM DUE TO THE RISK OF SYSTEM FAILURE. TO AVOID DAMAGE, INJURY, OR DEATH, THE USER OR APPLICATION DESIGNER MUST TAKE REASONABLY PRUDENT STEPS TO PROTECT AGAINST SYSTEM FAILURES, INCLUDING BUT NOT LIMITED TO BACK-UP OR SHUT DOWN MECHANISMS, BECAUSE EACH END-USER SYSTEM IS CUSTOMIZED AND DIFFERS FROM NATIONAL INSTRUMENTS' TESTING PLATFORMS AND BECAUSE A USER OR APPLICATION DESIGNER MAY USE NATIONAL INSTRUMENTS PRODUCTS IN COMBINATION WITH OTHER PRODUCTS IN A MANNER NOT EVALUATED OR CONTEMPLATED BY NATIONAL INSTRUMENTS, THE USER OR APPLICATION DESIGNER IS ULTIMATELY RESPONSIBLE FOR VERIFYING AND VALIDATING THE SUITABILITY OF NATIONAL INSTRUMENTS PRODUCTS WHENEVER NATIONAL INSTRUMENTS PRODUCTS ARE INCORPORATED IN A SYSTEM OR APPLICATION, INCLUDING, WITHOUT LIMITATION, THE APPROPRIATE DESIGN, PROCESS AND SAFETY LEVEL OF SUCH SYSTEM OR APPLICATION.

Contents

About This Manual

Conventions	xiii
Related Documentation.....	xiv

Chapter 1

Getting Started

Installing NI-DAQmx	1-1
Installing Other Software.....	1-1
Installing the Hardware.....	1-1
Device Self-Calibration	1-2
Device Pinouts	1-2
Device Specifications	1-2
Applying Signal Labels to the USB-621x.....	1-3
USB Cable Strain Relief.....	1-4
Mounting the USB-621x.....	1-6
Desktop Use.....	1-6
DIN Rail Mounting.....	1-6
Panel Mounting	1-7
USB Device Security Cable Slot	1-8

Chapter 2

DAQ System Overview

DAQ Hardware	2-1
DAQ-STC2.....	2-2
Calibration Circuitry.....	2-2
Signal Conditioning	2-3
Sensors and Transducers	2-3
Cables and Accessories.....	2-4
USB-621x Mass Termination Custom Cabling.....	2-4
Programming Devices in Software	2-5

Chapter 3

Connector and LED Information

I/O Connector Signal Descriptions.....	3-1
+5 V Power.....	3-3
+5 V Power as an Output.....	3-3
+5 V Power as an Input.....	3-3
USB Chassis Ground.....	3-4
USB Device Fuse Replacement.....	3-4
PWR/ACT LED Indicator.....	3-6

Chapter 4

Analog Input

Analog Input Range.....	4-2
Analog Input Ground-Reference Settings.....	4-3
Configuring AI Ground-Reference Settings in Software.....	4-5
Multichannel Scanning Considerations.....	4-5
Analog Input Data Acquisition Methods.....	4-8
Analog Input Digital Triggering.....	4-10
Field Wiring Considerations.....	4-10
Analog Input Timing Signals.....	4-11
AI Sample Clock Signal.....	4-14
Using an Internal Source.....	4-14
Using an External Source.....	4-14
Routing AI Sample Clock to an Output Terminal.....	4-14
Other Timing Requirements.....	4-14
AI Sample Clock Timebase Signal.....	4-15
AI Convert Clock Signal.....	4-16
Using an Internal Source.....	4-16
Using an External Source.....	4-16
Routing AI Convert Clock to an Output Terminal.....	4-16
Using a Delay from Sample Clock to Convert Clock.....	4-17
Other Timing Requirements.....	4-17
AI Convert Clock Timebase Signal.....	4-19
AI Hold Complete Event Signal.....	4-19
AI Start Trigger Signal.....	4-20
Using a Digital Source.....	4-20
Routing AI Start Trigger to an Output Terminal.....	4-20
AI Reference Trigger Signal.....	4-21
Using a Digital Source.....	4-22
Routing AI Reference Trigger to an Output Terminal.....	4-22
AI Pause Trigger Signal.....	4-22
Using a Digital Source.....	4-22

Getting Started with AI Applications in Software	4-22
Connecting Analog Input Signals on USB-6210/6211/6212 Devices	4-23
Connecting Floating Signal Sources	4-25
What Are Floating Signal Sources?	4-25
When to Use Differential Connections with Floating Signal Sources.....	4-25
When to Use Referenced Single-Ended Connections with Floating Signal Sources.....	4-25
When to Use Non-Referenced Single-Ended Connections with Floating Signal Sources.....	4-26
Using Differential Connections for Floating Signal Sources.....	4-27
Using Non-Referenced Single-Ended Connections for Floating Signal Sources.....	4-30
Using Referenced Single-Ended Connections for Floating Signal Sources.....	4-31
Connecting Ground-Referenced Signal Sources	4-31
What Are Ground-Referenced Signal Sources?.....	4-31
When to Use Differential Connections with Ground-Referenced Signal Sources	4-32
When to Use Non-Referenced Single-Ended Connections with Ground-Referenced Signal Sources	4-32
When to Use Referenced Single-Ended Connections with Ground-Referenced Signal Sources	4-33
Using Differential Connections for Ground-Referenced Signal Sources	4-34
Using Non-Referenced Single-Ended Connections for Ground-Referenced Signal Sources	4-35
Connecting Analog Input Signals on USB-6215/6216/6218 Devices	4-36
Taking Differential Measurements.....	4-36
Taking Referenced Single-Ended Measurements	4-37
Taking Non-Referenced Single-Ended Measurements	4-38

Chapter 5

Analog Output

AO Range	5-2
Minimizing Glitches on the Output Signal	5-2
Analog Output Data Generation Methods	5-2
Analog Output Digital Triggering	5-4
Connecting Analog Output Signals	5-4
Analog Output Timing Signals	5-5
AO Start Trigger Signal.....	5-5
Using a Digital Source	5-5
Routing AO Start Trigger to an Output Terminal.....	5-6

AO Pause Trigger Signal	5-6
Using a Digital Source.....	5-7
AO Sample Clock Signal	5-8
Using an Internal Source	5-8
Using an External Source	5-8
Routing AO Sample Clock to an Output Terminal	5-8
Other Timing Requirements	5-8
AO Sample Clock Timebase Signal.....	5-9
Getting Started with AO Applications in Software.....	5-10

Chapter 6

Digital I/O

Digital I/O on USB-6210/6211/6215/6218 Devices	6-1
Static DIO on USB-6210/6211/6215/6218 Devices	6-2
I/O Protection on USB-6210/6211/6215/6218 Devices.....	6-2
Increasing Current Drive on USB-6210/6211/6215/6218 Devices	6-3
Connecting Digital I/O Signals on USB-6210/6211/6215/6218 Devices.....	6-3
Getting Started with DIO Applications in Software on USB-6210/6211/6215/6218 Devices	6-4
Digital I/O on USB-6212/6216 Devices.....	6-4
Static DIO on USB-6212/6216 Devices	6-5
I/O Protection on USB-6212/6216 Devices.....	6-5
Programmable Power-Up States on USB-6212/6216 Devices	6-6
Increasing Current Drive on USB-6212/6216 Devices.....	6-6
Connecting Digital I/O Signals on USB-6212/6216 Devices.....	6-6
Getting Started with DIO Applications in Software on USB-6212/6216 Devices.....	6-7

Chapter 7

PFI

Using PFI Terminals as Timing Input Signals	7-2
Exporting Timing Output Signals Using PFI Terminals	7-3
Using PFI Terminals as Static Digital I/Os	7-3
Connecting PFI Input Signals.....	7-4
PFI Filters	7-4
I/O Protection	7-6
Programmable Power-Up States.....	7-6

Chapter 8

Counters

Counter Input Applications	8-2
Counting Edges	8-2
Single Point (On-Demand) Edge Counting	8-2
Buffered (Sample Clock) Edge Counting	8-3
Controlling the Direction of Counting	8-4
Pulse-Width Measurement	8-4
Single Pulse-Width Measurement	8-4
Buffered Pulse-Width Measurement	8-5
Period Measurement	8-6
Single Period Measurement	8-6
Buffered Period Measurement	8-7
Semi-Period Measurement	8-8
Single Semi-Period Measurement	8-8
Buffered Semi-Period Measurement	8-9
Frequency Measurement	8-10
Choosing a Method for Measuring Frequency	8-14
Position Measurement	8-15
Measurements Using Quadrature Encoders	8-16
Measurements Using Two Pulse Encoders	8-18
Buffered (Sample Clock) Position Measurement	8-18
Two-Signal Edge-Separation Measurement	8-19
Single Two-Signal Edge-Separation Measurement	8-20
Buffered Two-Signal Edge-Separation Measurement	8-20
Counter Output Applications	8-21
Simple Pulse Generation	8-21
Single Pulse Generation	8-21
Single Pulse Generation with Start Trigger	8-22
Retriggerable Single Pulse Generation	8-22
Pulse Train Generation	8-23
Continuous Pulse Train Generation	8-23
Finite Pulse Train Generation	8-24
Frequency Generation	8-25
Using the Frequency Generator	8-25
Frequency Division	8-26
Pulse Generation for ETS	8-26
Counter Timing Signals	8-27
Counter n Source Signal	8-28
Routing a Signal to Counter n Source	8-28
Routing Counter n Source to an Output Terminal	8-28

Counter <i>n</i> Gate Signal	8-29
Routing a Signal to Counter <i>n</i> Gate	8-29
Routing Counter <i>n</i> Gate to an Output Terminal	8-29
Counter <i>n</i> Aux Signal	8-29
Routing a Signal to Counter <i>n</i> Aux	8-29
Counter <i>n</i> A, Counter <i>n</i> B, and Counter <i>n</i> Z Signals	8-30
Routing Signals to A, B, and Z Counter Inputs	8-30
Counter <i>n</i> Up_Down Signal	8-30
Counter <i>n</i> HW Arm Signal	8-30
Routing Signals to Counter <i>n</i> HW Arm Input	8-31
Counter <i>n</i> Internal Output and Counter <i>n</i> TC Signals	8-31
Routing Counter <i>n</i> Internal Output to an Output Terminal	8-31
Frequency Output Signal	8-31
Routing Frequency Output to a Terminal	8-31
Default Counter/Timer Pinouts	8-32
Counter Triggering	8-33
Other Counter Features	8-34
Sample Clock	8-34
Cascading Counters	8-35
Counter Filters	8-35
Prescaling	8-36
Duplicate Count Prevention	8-37
Example Application That Works Correctly	
(No Duplicate Counting)	8-37
Example Application That Works Incorrectly	
(Duplicate Counting)	8-38
Example Application That Prevents Duplicate Count	8-38
Enabling Duplicate Count Prevention in NI-DAQmx	8-39

Chapter 9

Isolation and Digital Isolators on USB-6215/6216/6218 Devices

Digital Isolation	9-2
Benefits of an Isolated DAQ Device	9-3
Reducing Common-Mode Noise	9-3
Creating an AC Return Path	9-4
Isolated Systems	9-4
Non-Isolated Systems	9-4

Chapter 10
Digital Routing and Clock Generation

80 MHz Timebase..... 10-1
 20 MHz Timebase..... 10-1
 100 kHz Timebase 10-1

Chapter 11
Bus Interface

USB Signal Stream 11-1
 Data Transfer Methods 11-1
 Changing Data Transfer Methods 11-2

Chapter 12
Triggering

Triggering with a Digital Source 12-1

Appendix A
Device-Specific Information

USB-6210 A-2
 USB-6211/6215 A-4
 USB-6212/6216 Screw Terminal..... A-6
 USB-6212/6216 Mass Termination A-8
 USB-6212/6216 BNC A-13
 USB-6218 Screw Terminal..... A-19
 USB-6218 BNC A-21

Appendix B
Troubleshooting

Appendix C
Technical Support and Professional Services

Glossary

Index

Device Pinouts

Figure A-1.	USB-6210 Pinout	A-2
Figure A-2.	USB-6211/6215 Pinout	A-4
Figure A-3.	USB-6212/6216 Screw Terminal Pinout	A-6
Figure A-4.	USB-6212/6216 Mass Termination Pinout.....	A-9
Figure A-5.	USB-6212/6216 BNC Top Panel and Pinout.....	A-14
Figure A-13.	USB-6218 Screw Terminal Pinout	A-19
Figure A-14.	USB-6218 BNC Top Panel and Pinout.....	A-22

About This Manual

The *NI USB-621x User Manual* contains information about using the National Instruments USB-621x data acquisition (DAQ) devices with NI-DAQmx 8.9 and later. NI USB-6210, USB-6211, USB-6212, USB-6215, USB-6216, and USB-6218 devices feature up to 32 analog input (AI) channels, up to two analog output (AO) channels, two counters, and up to eight lines of digital input (DI) and up to eight lines of digital output (DO), or 32 bidirectional static DIO lines.

Conventions

The following conventions are used in this manual:

<>

Angle brackets that contain numbers separated by an ellipsis represent a range of values associated with a bit or signal name—for example, AO <3..0>.

»

The » symbol leads you through nested menu items and dialog box options to a final action. The sequence **File»Page Setup»Options** directs you to pull down the **File** menu, select the **Page Setup** item, and select **Options** from the last dialog box.



This icon denotes a note, which alerts you to important information.



This icon denotes a caution, which advises you of precautions to take to avoid injury, data loss, or a system crash. When this symbol is marked on a product, refer to the *Read Me First: Safety and Electromagnetic Compatibility* document for information about precautions to take.

bold

Bold text denotes items that you must select or click in the software, such as menu items and dialog box options. Bold text also denotes parameter names.

italic

Italic text denotes variables, emphasis, a cross-reference, or an introduction to a key concept. Italic text also denotes text that is a placeholder for a word or value that you must supply.

`monospace` Text in this font denotes text or characters that you should enter from the keyboard, sections of code, programming examples, and syntax examples. This font is also used for the proper names of disk drives, paths, directories, programs, subprograms, subroutines, device names, functions, operations, variables, filenames, and extensions.

Platform Text in this font denotes a specific platform and indicates that the text following it applies only to that platform.

Related Documentation

Each application software package and driver includes information about writing applications for taking measurements and controlling measurement devices. The following references to documents assume you have NI-DAQ 8.9 or later, and where applicable, version 7.1 or later of the NI application software.

NI-DAQmx for Windows

The *NI-DAQmx for USB Devices Getting Started Guide* describes how to install your NI-DAQmx for Windows software, your NI-DAQmx-supported DAQ device, and how to confirm that your device is operating properly. Select **Start»All Programs»National Instruments»NI-DAQ»NI-DAQmx for USB Devices Getting Started**.

The *NI-DAQ Readme* lists which devices are supported by this version of NI-DAQ. Select **Start»All Programs»National Instruments»NI-DAQ»NI-DAQ Readme**.

The *NI-DAQmx Help* contains general information about measurement concepts, key NI-DAQmx concepts, and common applications that are applicable to all programming environments. Select **Start»All Programs»National Instruments»NI-DAQ»NI-DAQmx Help**.

NI-DAQmx Base (Linux/Mac OS X/LabVIEW Mobile Module 8.x/ LabVIEW Touch Panel Module 8.x)

The *NI-DAQmx Base Getting Started Guide* describes how to install your NI-DAQmx Base software, your NI-DAQmx Base-supported DAQ device, and how to confirm that your device is operating properly. In Windows, select **Start»All Programs»National Instruments»NI-DAQmx Base»Documentation»Getting Started Guide**.

Getting Started with NI-DAQmx Base for Linux and Mac Users describes how to install your NI-DAQmx Base software, your NI-DAQmx Base-supported DAQ device, and how to confirm that your device is operating properly on your Mac/Linux machine.

The *NI-DAQmx Base Readme* lists which devices are supported by this version of NI-DAQmx Base. In Windows, select **Start»All Programs»National Instruments»NI-DAQmx Base»DAQmx Base Readme**.

The *NI-DAQmx Base VI Reference Help* contains VI reference and general information about measurement concepts. In LabVIEW, select **Help»NI-DAQmx Base VI Reference Help**.

The *NI-DAQmx Base C Reference Help* contains C reference and general information about measurement concepts. In Windows, select **Start»All Programs»National Instruments»NI-DAQmx Base»Documentation»C Function Reference Help**.



Note All NI-DAQmx Base documentation for Linux is installed at `/usr/local/natinst/nidaqmxbase/documentation`.



Note All NI-DAQmx Base documentation for Mac OS X is installed at `/Applications/National Instruments/NI-DAQmx Base/documentation`.

LabVIEW

If you are a new user, use the *Getting Started with LabVIEW* manual to familiarize yourself with the LabVIEW graphical programming environment and the basic LabVIEW features you use to build data acquisition and instrument control applications. Open the *Getting Started with LabVIEW* manual by selecting **Start»All Programs»National Instruments»LabVIEW»LabVIEW Manuals** or by navigating to the `labview\manuals` directory and opening `LV_Getting_Started.pdf`.

Use the *LabVIEW Help*, available by selecting **Help»Search the LabVIEW Help** in LabVIEW, to access information about LabVIEW programming concepts, step-by-step instructions for using LabVIEW, and reference information about LabVIEW VIs, functions, palettes, menus, and tools. Refer to the following locations on the **Contents** tab of the *LabVIEW Help* for information about NI-DAQmx:

- **Getting Started with LabVIEW»Getting Started with DAQ**—Includes overview information and a tutorial to learn how to take an NI-DAQmx measurement in LabVIEW using the DAQ Assistant.
- **VI and Function Reference»Measurement I/O VIs and Functions**—Describes the LabVIEW NI-DAQmx VIs and properties.
- **Taking Measurements**—Contains the conceptual and how-to information you need to acquire and analyze measurement data in LabVIEW, including common measurements, measurement fundamentals, NI-DAQmx key concepts, and device considerations.

LabWindows/CVI

The **Data Acquisition** book of the *LabWindows/CVI Help* contains measurement concepts for NI-DAQmx. This book also contains *Taking an NI-DAQmx Measurement in LabWindows/CVI*, which includes step-by-step instructions about creating a measurement task using the DAQ Assistant. In LabWindows™/CVI™, select **Help»Contents**, then select **Using LabWindows/CVI»Data Acquisition**.

The **NI-DAQmx Library** book of the *LabWindows/CVI Help* contains API overviews and function reference for NI-DAQmx. Select **Library Reference»NI-DAQmx Library** in the *LabWindows/CVI Help*.

Measurement Studio

If you program your NI-DAQmx-supported device in Measurement Studio using Visual C++, Visual C#, or Visual Basic .NET, you can interactively create channels and tasks by launching the DAQ Assistant from MAX or from within Visual Studio .NET. You can generate the configuration code based on your task or channel in Measurement Studio. Refer to the *DAQ Assistant Help* for additional information about generating code. You also can create channels and tasks, and write your own applications in your ADE using the NI-DAQmx API.

For help with NI-DAQmx methods and properties, refer to the NI-DAQmx .NET Class Library or the NI-DAQmx Visual C++ Class Library included in the *NI Measurement Studio Help*. For general help with programming

in Measurement Studio, refer to the *NI Measurement Studio Help*, which is fully integrated with the Microsoft Visual Studio .NET help. To view this help file in Visual Studio .NET, select **Measurement Studio»NI Measurement Studio Help**.

To create an application in Visual C++, Visual C#, or Visual Basic .NET, follow these general steps:

1. In Visual Studio .NET, select **File»New»Project** to launch the New Project dialog box.
2. Find the Measurement Studio folder for the language you want to create a program in.
3. Choose a project type. You add DAQ tasks as a part of this step.

ANSI C without NI Application Software

The *NI-DAQmx Help* contains API overviews and general information about measurement concepts. Select **Start»All Programs»National Instruments»NI-DAQmx Help**.

The *NI-DAQmx C Reference Help* describes the NI-DAQmx Library functions, which you can use with National Instruments data acquisition devices to develop instrumentation, acquisition, and control applications. Select **Start»All Programs»National Instruments»NI-DAQ»NI-DAQmx C Reference Help**.

.NET Languages without NI Application Software

With the Microsoft .NET Framework version 1.1 or later, you can use NI-DAQmx to create applications using Visual C# and Visual Basic .NET without Measurement Studio. You need Microsoft Visual Studio .NET 2003 or Microsoft Visual Studio 2005 for the API documentation to be installed.

The installed documentation contains the NI-DAQmx API overview, measurement tasks and concepts, and function reference. This help is fully integrated into the Visual Studio .NET documentation. To view the NI-DAQmx .NET documentation, go to **Start»Programs»National Instruments»NI-DAQ»NI-DAQmx .NET Reference Help**. Expand **NI Measurement Studio Help»NI Measurement Studio .NET Class Library»Reference** to view the function reference. Expand **NI Measurement Studio Help»NI Measurement Studio .NET Class Library»Using the Measurement Studio .NET Class Libraries** to view conceptual topics for using NI-DAQmx with Visual C# and Visual Basic .NET.

To get to the same help topics from within Visual Studio, go to **Help» Contents**. Select **Measurement Studio** from the **Filtered By** drop-down list and follow the previous instructions.

Device Documentation and Specifications

The *NI USB-621x Specifications* contains all specifications for the USB-6210, USB-6211, USB-6212, USB-6215, USB-6216, and USB-6218 M Series devices.

Documentation for supported devices and accessories, including PDF and help files describing device terminals, specifications, features, and operation are on the NI-DAQmx media that includes Device Documentation. Insert the media, open the Device Documentation directory, and double-click the Device Documents shortcut for your language to find, view, and print device documents.

Training Courses

If you need more help getting started developing an application with NI products, NI offers training courses. To enroll in a course or obtain a detailed course outline, refer to ni.com/training.

Technical Support on the Web

For additional support, refer to ni.com/support or zone.ni.com.



Note You can download these documents at ni.com/manuals.

DAQ specifications and manuals are available as PDFs. You must have Adobe Acrobat Reader with Search and Accessibility 5.0.5 or later installed to view the PDFs. Refer to the Adobe Systems Incorporated Web site at www.adobe.com to download Acrobat Reader. Refer to the National Instruments Product Manuals Library at ni.com/manuals for updated documentation resources.

Getting Started

NI USB-621x devices feature up to 32 analog input (AI) channels, up to two analog output (AO) channels, two counters, and up to eight lines of digital input (DI) and up to eight lines of digital output (DO), or 32 bidirectional static DIO lines.

Installing NI-DAQmx

The *NI-DAQmx for USB Devices Getting Started Guide*, which you can download from ni.com/manuals, offers NI-DAQmx users step-by-step instructions for installing software and hardware, configuring channels and tasks, and getting started developing an application.

Installing Other Software

If you are using other software, refer to the installation instructions that accompany your software.

Installing the Hardware

The *NI-DAQmx for USB Devices Getting Started Guide* contains non-software-specific information about how to install USB devices. Before installing your DAQ device, you must install the software you plan to use with the device.

Device Self-Calibration

NI recommends that you self-calibrate your USB-621x device after installation and whenever the ambient temperature changes. Self-calibration should be performed after the device has warmed up for the recommended time period. Refer to the *NI USB-621x Specifications* to find your device warm-up time. This function measures the onboard reference voltage of the device and adjusts the self-calibration constants to account for any errors caused by short-term fluctuations in the environment. Disconnect all external signals when you self-calibrate a device.

You can initiate self-calibration using Measurement & Automation Explorer (MAX), by completing the following steps.

1. Launch MAX.
2. Select **My System»Devices and Interfaces»NI-DAQmx Devices»your device**.
3. Initiate self-calibration using one of the following methods:
 - Click **Self-Calibrate** in the upper right corner of MAX.
 - Right-click the name of the device in the MAX configuration tree and select **Self-Calibrate** from the drop-down menu.



Note You can also programmatically self-calibrate your device with NI-DAQmx, as described in *Device Calibration* in the *NI-DAQmx Help* or the *LabVIEW Help* in version 8.0 or later.

Device Pinouts

Refer to Appendix A, *Device-Specific Information*, for USB-621x device pinouts.

Device Specifications

Refer to the *NI USB-621x Specifications*, available on the NI-DAQ Device Documentation Browser or from ni.com/manuals, for more detailed information about USB-621x devices.

Applying Signal Labels to the USB-621x

(USB-621x Screw Terminal Devices) Your USB-621x kit includes labels for the combicon connectors on USB-621x Screw Terminal devices. You can choose labels with pin numbers or signal names or blank labels. Choose one of the labels, align the correct label with the terminals printed on the top panel of your device or the 16-position combicon connector, and apply the label, as shown in Figure 1-1.

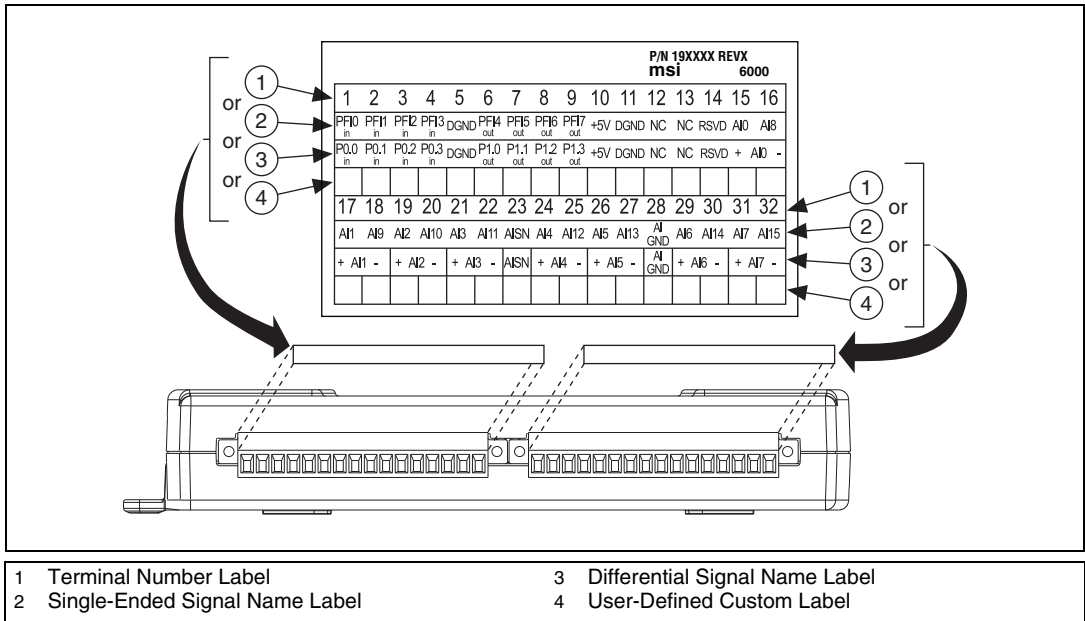

Figure 1-1. USB-621x Screw Terminal Signal Labels

USB Cable Strain Relief

You can provide strain relief for the USB cable in the following ways:

- **Cable Strain Relief Groove Method—(USB-621x Screw Terminal/Mass Termination Devices)** Press the USB cable into one of the two grooves on the underside of the USB-621x. Choose the USB cable groove that matches your USB cable size, as shown in Figure 1-2a.
- **Zip Tie Method—(USB-621x Screw Terminal/Mass Termination Devices)** Thread a zip tie through the zip tie bar on the underside of the USB-621x and tighten around the USB cable, as shown in Figure 1-2b.

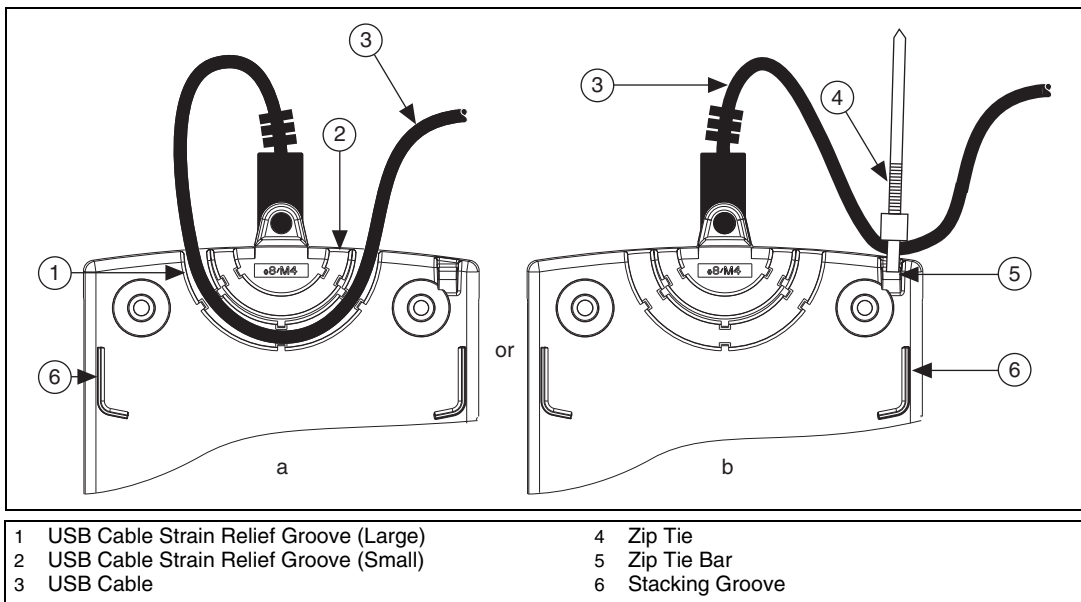

Figure 1-2. USB Cable Strain Relief Options on USB-621x Screw Terminal/Mass Termination Devices

- Locking USB Cable Method—(USB-621x BNC Devices)** Use the jackscrew on the locking USB cable (included in the USB-621x BNC kit) to securely attach the cable to the device, as shown in Figure 1-3.

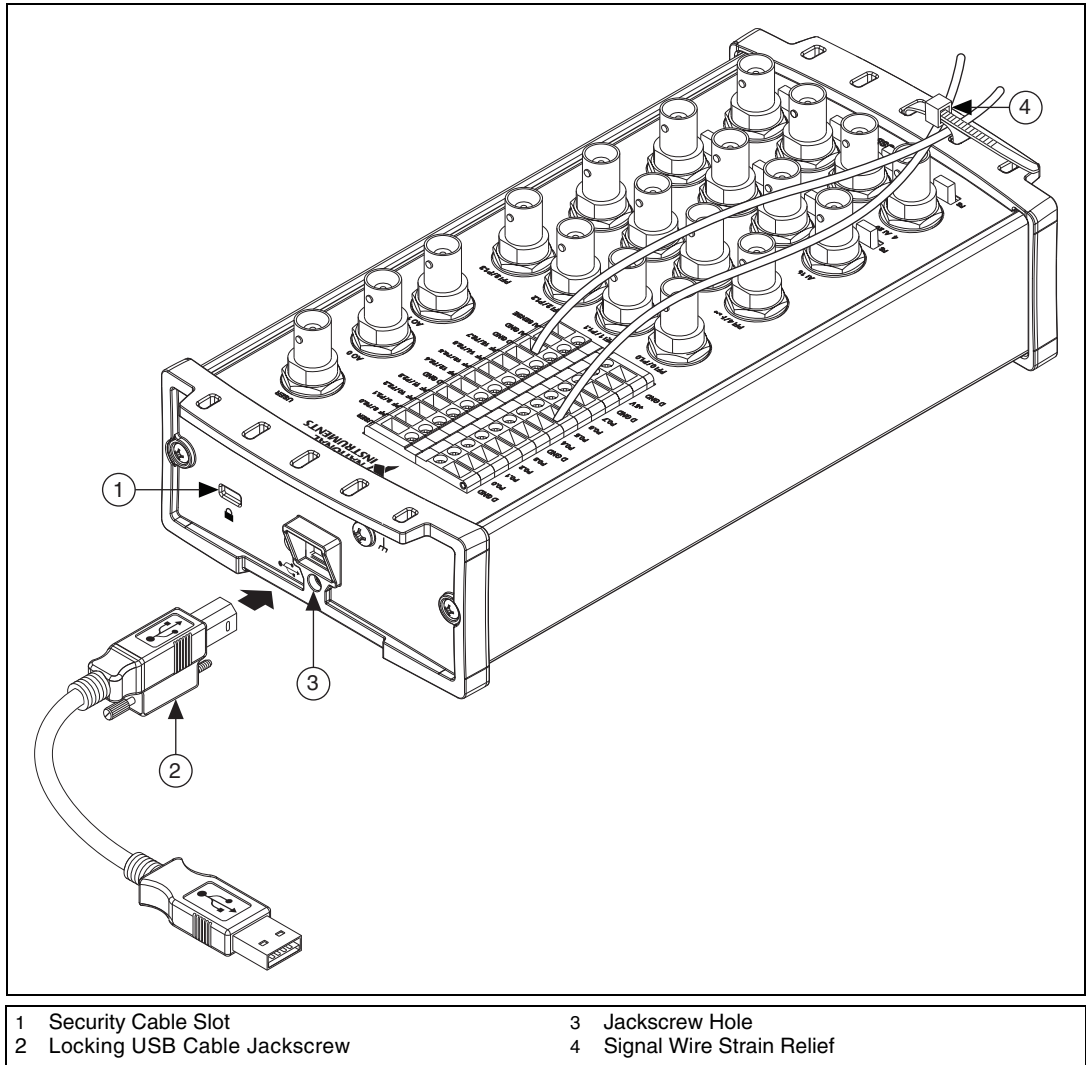

Figure 1-3. USB Cable Strain Relief on USB-621x BNC Devices



Note You can provide cable management for signal wires to/from the screw terminals and BNC connectors on USB-621x BNC devices by threading a zip tie through the strain relief holes and tightening it around the signal wires and BNC cables, as shown in Figure 1-3.

Mounting the USB-621x

You can use the USB-621x on a desktop or mount it to a standard DIN rail or a panel.

Desktop Use

You can use the USB-621x on a desktop. USB-621x Screw Terminal/Mass Termination devices have grooves on the underside that allow it to be stacked with other like-sized USB-621x devices, as shown in Figure 1-2.



Note USB-621x BNC devices cannot be stacked.

(USB-621x Screw Terminal/Mass Termination Devices) For secure desktop use, adhere the supplied rubber non-skid feet to the underside of the USB-621x device, as shown in Figure 1-4.



Note Do *not* apply the rubber feet if you are panel mounting the USB-621x or stacking the device on another USB-621x device.

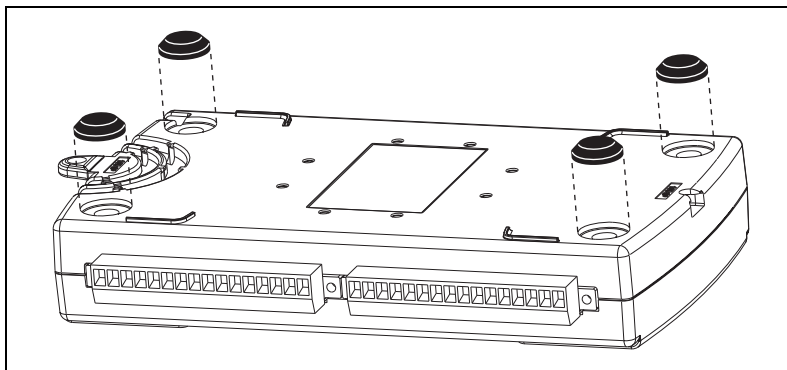

Figure 1-4. Rubber Feet Application

DIN Rail Mounting

The DIN rail mounting kit (part number 779689-01, not included in your USB-621x kit) is an accessory you can use to mount the USB-621x family of products to a standard DIN rail.



Note Apply strain relief, as described in the [USB Cable Strain Relief](#) section, *before* mounting the USB-621x to a DIN rail.

Panel Mounting

(USB-621x Screw Terminal/Mass Termination Devices) To mount the USB-621x to a board or panel, complete the following steps while referring to Figure 1-5.

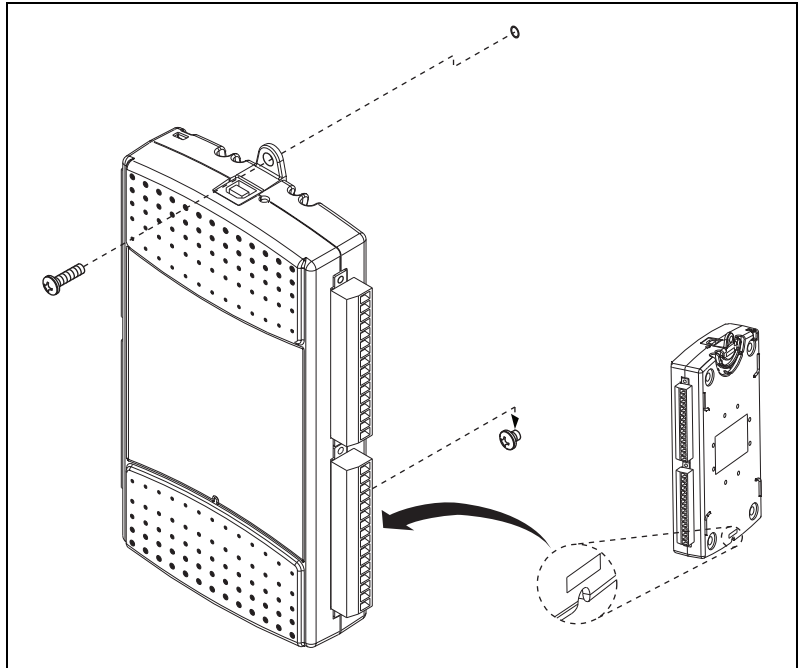

Figure 1-5. Mounting the USB-621x on a Panel



Note Do *not* apply the rubber feet to the USB-621x when panel mounting the device.



Note Apply strain relief, as described in the [USB Cable Strain Relief](#) section, *before* panel mounting the USB-621x.

1. Download and print the panel mounting template PDF attached in the KnowledgeBase document, *USB-621x Panel Mounting Template*. Go to ni.com/info and enter the info code `ex3x98` to locate the KnowledgeBase.
2. Using the template, mark the bottom point and top point on the panel.
 - (USB-621x Screw Terminal Devices)** The points will be 171.45 mm (6.75 in.) from each other.
 - (USB-621x Mass Termination Devices)** The points will be 182.56 mm (7.188 in.) from each other.

3. Remove the USB cable from the connector on the USB-621x.
4. Screw a #8 or M4 screw into the bottom point on the panel.
5. Set the USB-621x on the screw by fitting it into the bottom screw notch on the underside of the USB-621x.
6. Screw a #8 or M4 screw through the USB-621x top screw hole into the panel.

USB Device Security Cable Slot

(USB-621x BNC Devices) The security cable slot, shown in Figure 1-3, allows you to attach an optional antitheft device to your USB device.



Note The security cable is designed to act as a deterrent, but might not prevent the device from being mishandled or stolen. For more information, refer to the documentation that accompanied the security cable.



Note The security cable slot on the USB-621x BNC might not be compatible with all antitheft cables.

DAQ System Overview

Figure 2-1 shows a typical DAQ system, which includes the USB-621x device, programming software, and PC (DAQ systems involving the USB-621x Mass Termination device can also include signal conditioning devices and a cable for accessory connection). The following sections contain more information about the components of a typical DAQ system.

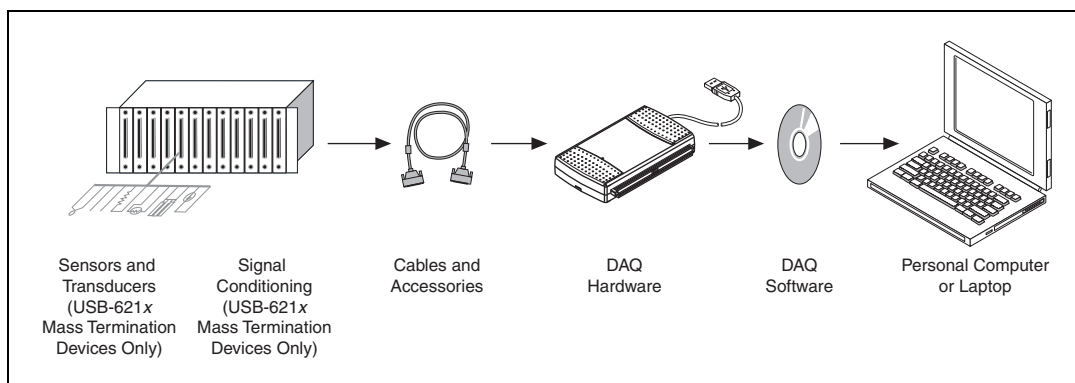

Figure 2-1. Components of a Typical DAQ System

DAQ Hardware

DAQ hardware digitizes signals, performs D/A conversions to generate analog output signals, and measures and controls digital I/O signals.

Figure 2-2 features components common to all USB-621x devices.

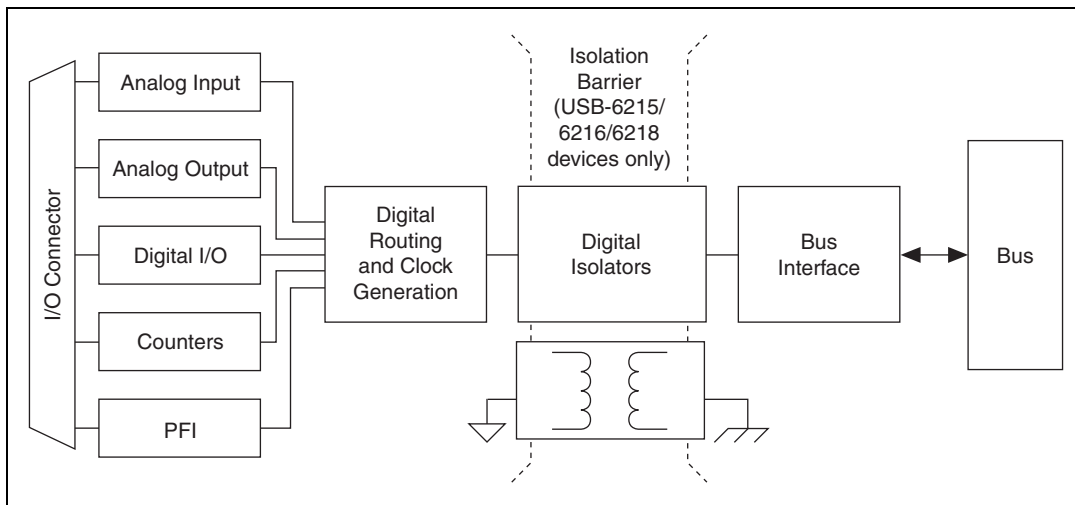

Figure 2-2. USB-621x Block Diagram

DAQ-STC2

The DAQ-STC2 implements a high-performance digital engine for M Series data acquisition hardware. Some key features of this engine include the following:

- Flexible AI and AO sample and convert timing
- Many triggering modes
- Independent AI, AO, and CTR FIFOs
- Generation and routing of internal and external timing signals
- Two flexible 32-bit counter/timer modules with hardware gating
- Static DI, DO, and DIO signals
- USB Hi-Speed 2.0 interface
- Up to four USB Signal Streams for acquisition and generation functions

Calibration Circuitry

The USB-621x analog inputs and outputs have calibration circuitry to correct gain and offset errors. You can calibrate the device to minimize AI and AO errors caused by time and temperature drift at run time. No external circuitry is necessary; an internal reference ensures high accuracy and stability over time and temperature changes.

Factory-calibration constants are permanently stored in an onboard EEPROM and cannot be modified. When you self-calibrate the device, software stores new constants in a user-modifiable section of the EEPROM. To return a device to its initial factory calibration settings, software can copy the factory-calibration constants to the user-modifiable section of the EEPROM. Refer to the *NI-DAQmx Help* or the *LabVIEW Help* in version 8.0 or later for more information about using calibration constants.

For a detailed calibration procedure for USB-621x devices, refer to the *B/E/M/S Series Calibration Procedure for NI-DAQmx* by clicking **Manual Calibration Procedures** on ni.com/calibration.

Signal Conditioning

Many sensors and transducers require signal conditioning before a measurement system can effectively and accurately acquire the signal. The front-end signal conditioning system can include functions such as signal amplification, attenuation, filtering, electrical isolation, simultaneous sampling, and multiplexing. In addition, many transducers require excitation currents or voltages, bridge completion, linearization, or high amplification for proper and accurate operation. Therefore, most computer-based measurement systems include some form of signal conditioning in addition to plug-in data acquisition DAQ devices.

Sensors and Transducers

Sensors can generate electrical signals to measure physical phenomena, such as temperature, force, sound, or light. Some commonly used sensors are strain gauges, thermocouples, thermistors, angular encoders, linear encoders, and resistance temperature detectors (RTDs).

To measure signals from these various transducers, you must convert them into a form that a DAQ device can accept. For example, the output voltage of most thermocouples is very small and susceptible to noise. Therefore, you may need to amplify or filter the thermocouple output before digitizing it. The manipulation of signals to prepare them for digitizing is called signal conditioning.

For more information about sensors, refer to the following documents:

- For general information about sensors, visit ni.com/sensors.
- If you are using LabVIEW, refer to the *LabVIEW Help* by selecting **Help»Search the LabVIEW Help** in LabVIEW and then navigate to the **Taking Measurements** book on the **Contents** tab.

- If you are using other application software, refer to *Common Sensors* in the *NI-DAQmx Help* or the *LabVIEW Help* in version 8.0 or later.

Cables and Accessories

Cable and accessory options for USB-621x devices are as follows:

- **Combicon Accessory for USB-621x Screw Terminal Devices (Optional)**—Your USB-621x kit includes combicon connectors with signal labels. The NI USB-621x Accessory Kit (part number 779807-01) contains four combicon connectors with screws, a screwdriver, and additional signal labels. You can use the combicon accessory to create custom connection solutions for USB-621x Screw Terminal devices.
- **Cables and Accessories for USB-621x Mass Termination Devices**—Refer to the [USB-6212/6216 Mass Termination Cables and Accessories](#) section of Appendix A, *Device-Specific Information*, for a list of cables and accessories for USB-621x Mass Termination devices.
- **BNC Cables for USB-621x BNC Devices**—Use standard BNC cables with the USB-621x BNC device. The BNC Male (Plug) to BNC Male (Plug) Cables Kit (part number 779697-01) contains four one-meter BNC cables for use with USB-621x BNC devices.

USB-621x Mass Termination Custom Cabling

NI offers cables and accessories for many applications. However, if you want to develop your own cable, adhere to the following guidelines for best results:

- For AI signals, use shielded, twisted-pair wires for each AI pair of differential inputs. Connect the shield for each signal pair to the ground reference at the source.
- Route the analog lines separately from the digital lines.
- When using a cable shield, use separate shields for the analog and digital sections of the cable. Failure to do so results in noise coupling into the analog signals from transient digital signals.

For more information about the connectors used for DAQ devices, refer to the KnowledgeBase document, *Specifications and Manufacturers for Board Mating Connectors*, by going to ni.com/info and entering the info code `rdspmb`.

Programming Devices in Software

National Instruments measurement devices are packaged with NI-DAQ driver software, an extensive library of functions and VIs you can call from your application software, such as LabVIEW or LabWindows/CVI, to program all the features of your NI measurement devices. Driver software has an application programming interface (API), which is a library of VIs, functions, classes, attributes, and properties for creating applications for your device.

USB-621*x* devices use the NI-DAQmx driver. NI-DAQmx includes a collection of programming examples to help you get started developing an application. You can modify example code and save it in an application. You can use examples to develop a new application or add example code to an existing application.

To locate LabVIEW, LabWindows/CVI, Measurement Studio, Visual Basic, and ANSI C examples, refer to the KnowledgeBase document, *Where Can I Find NI-DAQmx Examples?*, by going to ni.com/info and entering the info code `daqmxexp`.

For additional examples, refer to zone.ni.com.

Table 2-1 lists the earliest NI-DAQmx support version for each NI USB-621*x* device.

Table 2-1. NI USB-621*x* NI-DAQmx Software Support

Device	NI-DAQmx Version Support
USB-6210/6211/6215/6218 Screw Terminal	NI-DAQmx 8.3 and later
USB-6212/6216 Screw Terminal	NI-DAQmx 8.6 and later
USB-6212/6216 Mass Termination	NI-DAQmx 8.7.1 and later
USB-6212/6216/6218 BNC	NI-DAQmx 8.9 and later

Connector and LED Information

The *I/O Connector Signal Descriptions* and *+5 V Power* sections contain information about NI USB-621x connectors. The *PWR/ACT LED Indicator* section contains information about the NI USB-621x PWR/ACT LED. Refer to Appendix A, *Device-Specific Information*, for device I/O connector pinouts. Refer to the *Applying Signal Labels to the USB-621x* section of Chapter 1, *Getting Started*, for information about applying signal labels.

I/O Connector Signal Descriptions

Table 3-1 describes the signals found on the I/O connectors. Not all signals are available on all devices.

Table 3-1. I/O Connector Signals

Signal Name	Reference	Direction	Description
AI GND	—	—	Analog Input Ground —These terminals are the reference point for single-ended AI measurements in RSE mode and the bias current return point for differential measurements. All three ground references—AI GND, AO GND, and D GND—are connected on the device.
AI <0..31>	Varies	Input	Analog Input Channels 0 to 31 —For single-ended measurements, each signal is an analog input voltage channel. In RSE mode, AI GND is the reference for these signals. In NRSE mode, the reference for each AI <0..31> signal is AI SENSE. For differential measurements, AI 0 and AI 8 are the positive and negative inputs of differential analog input channel 0. Similarly, the following signal pairs also form differential input channels: <AI 1, AI 9>, <AI 2, AI 10>, <AI 3, AI 11>, <AI 4, AI 12>, <AI 5, AI 13>, <AI 6, AI 14>, <AI 7, AI 15>, <AI 16, AI 24>, <AI 17, AI 25>, <AI 18, AI 26>, <AI 19, AI 27>, <AI 20, AI 28>, <AI 21, AI 29>, <AI 22, AI 30>, <AI 23, AI 31>
AI SENSE	—	Input	Analog Input Sense —In NRSE mode, the reference for each AI <0..31> signal is AI SENSE.

Table 3-1. I/O Connector Signals (Continued)

Signal Name	Reference	Direction	Description
AO <0..1>	AO GND	Output	Analog Output Channels 0 to 1 —These terminals supply the voltage output of AO channels 0 to 1.
AO GND	—	—	Analog Output Ground —AO GND is the reference for AO <0..1>. All three ground references—AI GND, AO GND, and D GND—are connected on the device.
D GND	—	—	Digital Ground —D GND supplies the reference for PFI <0..15>/P0/P1 and +5 V. All three ground references—AI GND, AO GND, and D GND—are connected on the device.
+5 V	D GND	Input or Output	+5 V Power —These terminals provide a +5 V power source or can be used to externally power the digital outputs.
PFI <0..3>, PFI <8..11>/P0.<0..7>	D GND	Input	(USB-6210/6211/6215/6218 Devices) Programmable Function Interface or Static Digital Input Channels 0 to 7 —Each PFI terminal can be used to supply an external source for AI, AO, or counter/timer inputs. You also can use these terminals as static digital input lines.
PFI <4..7>, PFI <12..15>/P1.<0..7>	D GND	Output	(USB-6210/6211/6215/6218 Devices) Programmable Function Interface or Static Digital Output Channels 0 to 7 —You can route many different internal AI, AO, or counter/timer outputs to each PFI terminal. You also can use these terminals as static digital output lines.
P0.<0..15>*	D GND	Input or Output	(USB-6212/6216 Devices) Port 0 Digital I/O Channels 0 to 15 —You can individually configure each signal as an input or output.
PFI <0..7>/P1.<0..7>, PFI <8..15>/P2.<0..7>	D GND	Input or Output	(USB-6212/6216 Devices) Programmable Function Interface or Digital I/O Channels 0 to 15 —Each of these terminals can be individually configured as a PFI terminal or a digital I/O terminal. As a PFI input, each terminal can be used to supply an external source for AI, AO, DI, and DO timing signals or counter/timer inputs. As a PFI output, you can route many different internal AI, AO, DI, or DO timing signals to each PFI terminal. You also can route the counter/timer outputs to each PFI terminal. As a Port 1 or Port 2 digital I/O signal, you can individually configure each signal as an input or output.

Table 3-1. I/O Connector Signals (Continued)

Signal Name	Reference	Direction	Description
USER	—	—	(USB-621x BNC Devices) User-Defined Channel —The USER BNC connector allows you to use a BNC connector for a digital or timing I/O signal of your choice. The USER BNC connector is internally routed to the USER screw terminal. Refer to the appropriate <i>USER</i> section for your USB-621x BNC device in Appendix A, <i>Device-Specific Information</i> , for more information about the USER signal.
NC	—	—	No connect —Do not connect signals to these terminals.
* USB-6212/6216 BNC/Mass Termination devices have eight digital I/O lines, P0.<0..7>.			

+5 V Power

The +5 V terminals on the I/O connector can be use as either an output or an input. Both terminals are internally connected on the USB-621x.

+5 V Power as an Output

Because the USB-621x devices are bus powered, there is a 50 mA limit on the *total* current that can be drawn from the +5 V terminals and the digital outputs. The USB-621x monitors the total current and drops the voltage on all of the digital outputs and the +5 V terminals if the 50 mA limit is exceeded.

+5 V Power as an Input

If you have high current loads for the digital outputs to drive, you can exceed the 50 mA internal limit by connecting an external +5 V power source to the +5 V terminals. These terminals are protected against undervoltage and overvoltage, and they have a fuse to protect them from short circuit conditions¹. If your USB-621x device has more than one +5 V terminal, you can connect the external power supply to one terminal and use the other as a power source.

¹ USB-621x Screw Terminal/BNC devices have a 350 mA self-resetting fuse. USB-621x Mass Termination devices have a 750 mA user-replaceable socketed fuse. Refer to the *USB Device Fuse Replacement* section for information about replacing socketed fuses.

USB Chassis Ground

(USB-621x BNC Devices) For EMC compliance, the chassis of the USB-621x BNC device *must* be connected to earth ground through the chassis ground.

The wire should be AWG 16 or larger solid copper wire with a maximum length of 1.5 m (5 ft). Attach the wire to the earth ground of the facility's power system. For more information about earth ground connections, refer to the KnowledgeBase document, *Earth Grounding for Test and Measurement Devices*, by going to ni.com/info and entering the info code `earthground`.

You can attach a wire to the ground lug screw of any USB-621x BNC device, as shown in Figure 3-1.

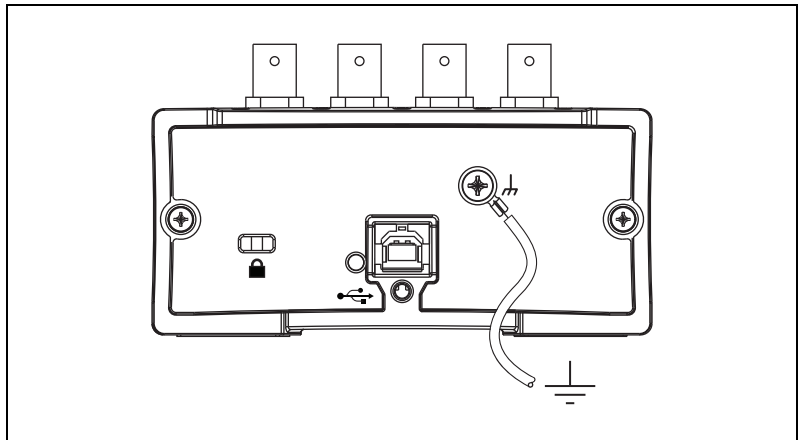

Figure 3-1. Grounding a USB-621x BNC Device through the Ground Lug Screw

USB Device Fuse Replacement

(USB-621x Mass Termination Devices) USB-621x Mass Termination devices have a replaceable 0.75A, 125V fuse (Littelfuse part number 0453.750) that protects the device from overcurrent through the +5 V terminal(s).

To replace a broken fuse in the USB-621x Mass Termination, complete the following steps while referring to Figure 3-2.

1. Remove the USB cable and any I/O signal wires from the device.
2. Remove the four Phillips screws on the bottom of the device to remove the device top. You may have to remove the rubber feet.

3. Replace the broken fuse in the socket. Figure 3-2 shows the fuse location.

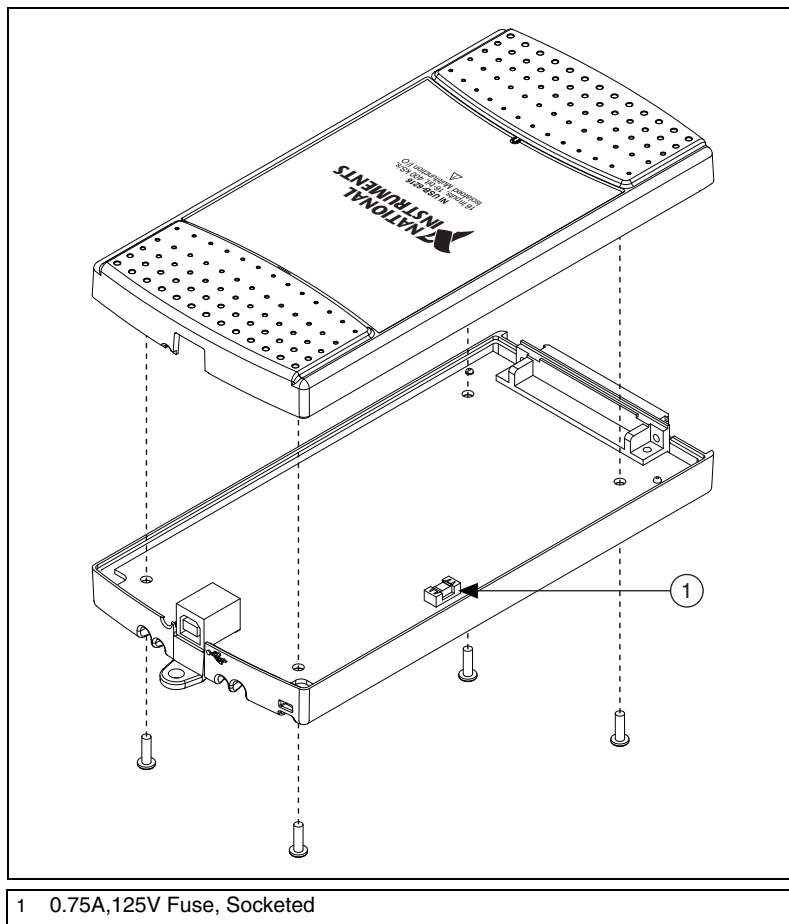

Figure 3-2. USB-621x Mass Termination Fuse Location

4. Replace the device top and reattach with the screws.



Note Unscrewing and reinstalling the thread-forming screws over time will produce a compromised connection between the device top and bottom.

PWR/ACT LED Indicator

The PWR/ACT LED indicator indicates device status. Table 3-2 shows the behavior of the PWR/ACT LED.

Table 3-2. PWR/ACT LED Status

LED State	Device Status
Not lit	Device not powered or device error. Refer to ni.com/support if device is powered.
On, not blinking	Device error. Refer to ni.com/support .
Single-blink	Operating normally. Connected to USB Hi-Speed port. Refer to the <i>NI USB-621x Specifications</i> for more information.
Double-blink	Connected to USB Full-Speed port. Device performance might be affected. Refer to the <i>NI USB-621x Specifications</i> for more information.

Analog Input

Figure 4-1 shows the analog input circuitry of USB-621x devices.

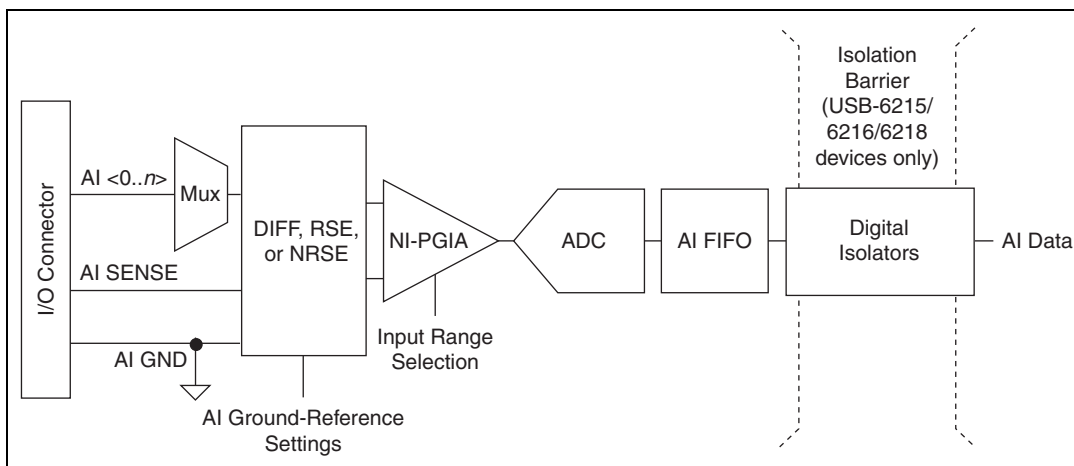

Figure 4-1. USB-621x Analog Input Circuitry

The main blocks featured in the USB-621x analog input circuitry are as follows:

- **I/O Connector**—You can connect analog input signals to the USB-621x device through the I/O connector. The proper way to connect analog input signals depends on the analog input ground-reference settings, described in the [Analog Input Ground-Reference Settings](#) section. Also refer to Appendix A, [Device-Specific Information](#), for device I/O connector pinouts.
- **Mux**—Each USB-621x device has one analog-to-digital converter (ADC). The multiplexers (mux) route one AI channel at a time to the ADC through the NI-PGIA.
- **AI Ground-Reference Settings**—The analog input ground-reference settings circuitry selects between differential (DIFF), referenced single-ended (RSE), and non-referenced single-ended (NRSE) input modes. Each AI channel can use a different mode.

- **NI-PGIA**—The NI programmable gain instrumentation amplifier (NI-PGIA) is a measurement and instrument class amplifier that minimizes settling times for all input ranges. The NI-PGIA can amplify or attenuate an AI signal to ensure that you use the maximum resolution of the ADC.

USB-621x devices use the NI-PGIA to deliver high accuracy even when sampling multiple channels with small input ranges at fast rates. USB-621x devices can sample channels in any order at the maximum conversion rate, and you can individually program each channel in a sample with a different input range.

- **ADC**—The analog-to-digital converter (ADC) digitizes the AI signal by converting the analog voltage into a digital number.
- **AI FIFO**—USB-621x devices can perform both single and multiple A/D conversions of a fixed or infinite number of samples. A large first-in-first-out (FIFO) buffer holds data during AI acquisitions to ensure that no data is lost. USB-621x devices can handle multiple A/D conversion operations with DMA, interrupts, or programmed I/O.
- **Isolation Barrier and Digital Isolators**—Refer to Chapter 9, [Isolation and Digital Isolators on USB-6215/6216/6218 Devices](#), for more information.

Analog Input Range

The input range affects the resolution of the USB-621x device for an AI channel. For example, a 16-bit ADC converts analog inputs into one of 65,536 ($= 2^{16}$) codes—that is, one of 65,536 possible digital values. So, for an input range of -10 V to 10 V , the voltage of each code of a 16-bit ADC is:

$$\frac{(10\text{ V} - (-10\text{ V}))}{2^{16}} = 305\ \mu\text{V}$$

USB-621x devices use a calibration method that requires some codes (typically about 5% of the codes) to lie outside of the specified range. This calibration method improves absolute accuracy, but it increases the nominal resolution of input ranges by about 5% over what the formula shown above would indicate.

Choose an input range that matches the expected input range of your signal. A large input range can accommodate a large signal variation, but reduces the voltage resolution. Choosing a smaller input range improves the voltage resolution, but may result in the input signal going out of range.

For more information about setting ranges, refer to the *NI-DAQmx Help* or the *LabVIEW Help* in version 8.0 or later.

The following table shows the input ranges and resolutions supported by USB-621x devices.

Input Range	Nominal Resolution Assuming 5% Over Range
-10 V to 10 V	320 μ V
-5 V to 5 V	160 μ V
-1 V to 1 V	32 μ V
-200 mV to 200 mV	6.4 μ V

Analog Input Ground-Reference Settings

USB-621x devices support the following analog input ground-reference settings:

- **Differential Mode**—In DIFF mode, USB-621x devices measure the difference in voltage between two AI signals.
- **Referenced Single-Ended Mode**—In RSE mode, USB-621x devices measure the voltage of an AI signal relative to AI GND.
- **Non-Referenced Single-Ended Mode**—In NRSE mode, USB-621x devices measure the voltage of an AI signal relative to the AI SENSE input.

The AI ground-reference setting determines how you should connect your AI signals to the USB-621x device. For more information, refer to one of the following sections depending on your device:

- [Connecting Analog Input Signals on USB-6210/6211/6212 Devices](#)
- [Connecting Analog Input Signals on USB-6215/6216/6218 Devices](#)

Ground-reference settings are programmed on a per-channel basis. For example, you might configure the device to scan 12 channels—four differentially-configured channels and eight single-ended channels.

USB-621x devices implement the different analog input ground-reference settings by routing different signals to the NI-PGIA. The NI-PGIA is a differential amplifier. That is, the NI-PGIA amplifies (or attenuates) the difference in voltage between its two inputs. The NI-PGIA drives the ADC

with this amplified voltage. The amount of amplification (the gain) is determined by the analog input range, as shown in Figure 4-2.

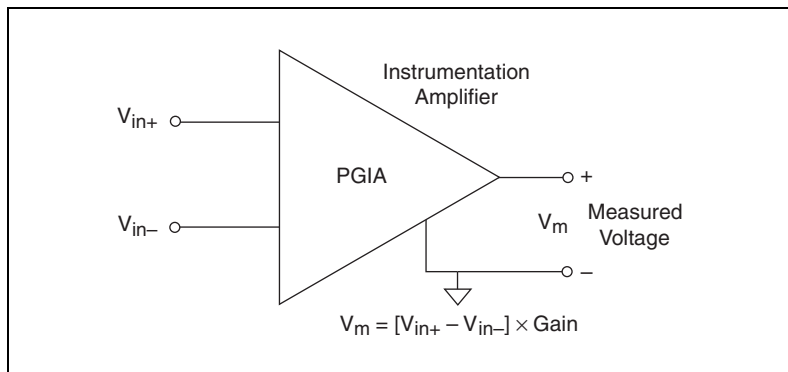

Figure 4-2. NI-PGIA

Table 4-1 shows how signals are routed to the NI-PGIA.

Table 4-1. Signals Routed to the NI-PGIA

AI Ground-Reference Settings	Signals Routed to the Positive Input of the NI-PGIA (V_{in+})	Signals Routed to the Negative Input of the NI-PGIA (V_{in-})
RSE	AI <0..31>	AI GND
NRSE	AI <0..31>	AI SENSE
DIFF	AI <0..7>	AI <8..15>
	AI <16..23>	AI <24..31>

For differential measurements, AI 0 and AI 8 are the positive and negative inputs of differential analog input channel 0. For a complete list of signal pairs that form differential input channels, refer to the [I/O Connector Signal Descriptions](#) section of Chapter 3, [Connector and LED Information](#). AI ground-reference setting is sometimes referred to as AI terminal configuration.



Caution The maximum input voltages rating of AI signals with respect to AI GND (and for differential signals with respect to each other) are listed in the *NI USB-621x Specifications*. Exceeding the maximum input voltage of AI signals distorts the measurement results. Exceeding the maximum input voltage rating also can damage the device and the computer. NI is *not* liable for any damage resulting from such signal connections.

Configuring AI Ground-Reference Settings in Software

You can program channels on an USB-621x device to acquire with different ground references.

To enable multimode scanning in LabVIEW, use NI-DAQmx `Create Virtual Channel.vi` of the NI-DAQmx API. You must use a new VI for each channel or group of channels configured in a different input mode. In Figure 4-3, channel 0 is configured in differential mode, and channel 1 is configured in referenced single-ended mode.

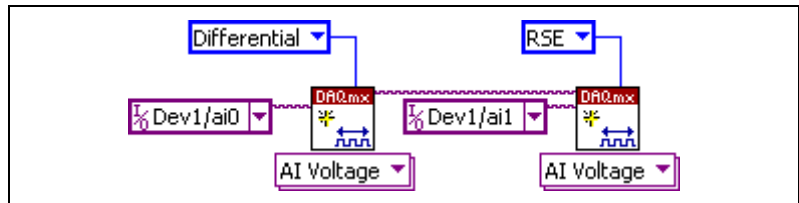

Figure 4-3. Enabling Multimode Scanning in LabVIEW

To configure the input mode of your voltage measurement using the DAQ Assistant, use the **Terminal Configuration** drop-down list. Refer to the *DAQ Assistant Help* for more information about the DAQ Assistant.

To configure the input mode of your voltage measurement using the NI-DAQmx C API, set the **terminalConfig** property. Refer to the *NI-DAQmx C Reference Help* for more information.

Multichannel Scanning Considerations

USB-621x devices can scan multiple channels at high rates and digitize the signals accurately. However, you should consider several issues when designing your measurement system to ensure the high accuracy of your measurements.

In multichannel scanning applications, accuracy is affected by settling time. When your USB-621x device switches from one AI channel to another AI channel, the device configures the NI-PGIA with the input range of the new channel. The NI-PGIA then amplifies the input signal with the gain for the new input range. Settling time refers to the time it takes the NI-PGIA to amplify the input signal to the desired accuracy before it is sampled by the ADC. The *NI USB-621x Specifications* lists settling time.

USB-621x devices are designed to have fast settling times. However, several factors can increase the settling time which decreases the accuracy

of your measurements. To ensure fast settling times, you should do the following (in order of importance):

- **Use Low Impedance Sources**—To ensure fast settling times, your signal sources should have an impedance of $<1\text{ k}\Omega$. Large source impedances increase the settling time of the NI-PGIA, and so decrease the accuracy at fast scanning rates.

Settling times increase when scanning high-impedance signals due to a phenomenon called charge injection. Multiplexers contain switches, usually made of switched capacitors. When one of the channels, for example channel 0, is selected in a multiplexer, those capacitors accumulate charge. When the next channel, for example channel 1, is selected, the accumulated charge leaks backward through channel 1. If the output impedance of the source connected to channel 1 is high enough, the resulting reading of channel 1 can be partially affected by the voltage on channel 0. This effect is referred to as ghosting.

If your source impedance is high, you can decrease the scan rate to allow the NI-PGIA more time to settle. Another option is to use a voltage follower circuit external to your DAQ device to decrease the impedance seen by the DAQ device. Refer to the KnowledgeBase document, *Decreasing the Source Impedance of an Analog Input Signal*, by going to ni.com/info and entering the info code `rdbbis`.

- **Use Short High-Quality Cabling**—Using short high-quality cables can minimize several effects that degrade accuracy including crosstalk, transmission line effects, and noise. The capacitance of the cable also can increase the settling time.

National Instruments recommends using individually shielded, twisted-pair wires that are 2 m or less to connect AI signals to the device. Refer to the [Connecting Analog Input Signals on USB-6210/6211/6212 Devices](#) or [Connecting Analog Input Signals on USB-6215/6216/6218 Devices](#) section for more information.

- **Carefully Choose the Channel Scanning Order**
 - **Avoid Switching from a Large to a Small Input Range**—Switching from a channel with a large input range to a channel with a small input range can greatly increase the settling time.

Suppose a 4 V signal is connected to channel 0 and a 1 mV signal is connected to channel 1. The input range for channel 0 is -10 V to 10 V and the input range of channel 1 is -200 mV to 200 mV .

When the multiplexer switches from channel 0 to channel 1, the input to the NI-PGIA switches from 4 V to 1 mV. The approximately 4 V step from 4 V to 1 mV is 1,000% of the new

full-scale range. For a 16-bit device to settle within 0.0015% (15 ppm or 1 LSB) of the ± 200 mV full-scale range on channel 1, the input circuitry must settle to within 0.000031% (0.31 ppm or 1/50 LSB) of the ± 10 V range. Some devices can take many microseconds for the circuitry to settle this much.

To avoid this effect, you should arrange your channel scanning order so that transitions from large to small input ranges are infrequent.

In general, you do not need this extra settling time when the NI-PGIA is switching from a small input range to a larger input range.

- **Insert Grounded Channel between Signal Channels**—Another technique to improve settling time is to connect an input channel to ground. Then insert this channel in the scan list between two of your signal channels. The input range of the grounded channel should match the input range of the signal after the grounded channel in the scan list.

Consider again the example above where a 4 V signal is connected to channel 0 and a 1 mV signal is connected to channel 1. Suppose the input range for channel 0 is -10 V to 10 V and the input range of channel 1 is -200 mV to 200 mV.

You can connect channel 2 to AI GND (or you can use the internal ground signal; refer to *Internal Channels* in the *NI-DAQmx Help*). Set the input range of channel 2 to -200 mV to 200 mV to match channel 1. Then scan channels in the order: 0, 2, 1.

Inserting a grounded channel between signal channels improves settling time because the NI-PGIA adjusts to the new input range setting faster when the input is grounded.

- **Minimize Voltage Step between Adjacent Channels**—When scanning between channels that have the same input range, the settling time increases with the voltage step between the channels. If you know the expected input range of your signals, you can group signals with similar expected ranges together in your scan list.

For example, suppose all channels in a system use a -5 to 5 V input range. The signals on channels 0, 2, and 4 vary between 4.3 V and 5 V. The signals on channels 1, 3, and 5 vary between -4 V and 0 V. Scanning channels in the order 0, 2, 4, 1, 3, 5 produces more accurate results than scanning channels in the order 0, 1, 2, 3, 4, 5.

- **Avoid Scanning Faster Than Necessary**—Designing your system to scan at slower speeds gives the NI-PGIA more time to settle to a more accurate level. Consider the following examples:
 - Example 1—Averaging many AI samples can increase the accuracy of the reading by decreasing noise effects. In general, the more points you average, the more accurate the final result. However, you may choose to decrease the number of points you average and slow down the scanning rate.

Suppose you want to sample 10 channels over a period of 20 ms and average the results. You could acquire 250 points from each channel at a scan rate of 125 kS/s. Another method would be to acquire 500 points from each channel at a scan rate of 250 kS/s. Both methods take the same amount of time. Doubling the number of samples averaged (from 250 to 500) decreases the effect of noise by a factor of 1.4 (the square root of 2). However, doubling the number of samples (in this example) decreases the time the NI-PGIA has to settle from 8 μ s to 4 μ s. In some cases, the slower scan rate system returns more accurate results.
 - Example 2—If the time relationship between channels is not critical, you can sample from the same channel multiple times and scan less frequently. For example, suppose an application requires averaging 100 points from channel 0 and averaging 100 points from channel 1. You could alternate reading between channels—that is, read one point from channel 0, then one point from channel 1, and so on. You also could read all 100 points from channel 0 then read 100 points from channel 1. The second method switches between channels much often and is affected less by settling time.

Analog Input Data Acquisition Methods

When performing analog input measurements, you either can perform software-timed or hardware-timed acquisitions:

- **Software-Timed Acquisitions**—With a software-timed acquisition, software controls the rate of the acquisition. Software sends a separate command to the hardware to initiate each ADC conversion. In NI-DAQmx, software-timed acquisitions are referred to as having on-demand timing. Software-timed acquisitions are also referred to as immediate or static acquisitions and are typically used for reading a single sample of data.

- **Hardware-Timed Acquisitions**—With hardware-timed acquisitions, a digital hardware signal, AI Sample Clock, controls the rate of the acquisition. This signal can be generated internally on your device or provided externally.

Hardware-timed acquisitions have several advantages over software-timed acquisitions:

- The time between samples can be much shorter.
- The timing between samples is deterministic.
- Hardware-timed acquisitions can use hardware triggering.

Hardware-timed operations are buffered. In a buffered acquisition, data is moved from the DAQ device's onboard FIFO memory to a PC buffer using USB signal streams or programmed I/O before it is transferred to application memory. Buffered acquisitions typically allow for much faster transfer rates than non-buffered acquisitions because data is moved in large blocks, rather than one point at a time.

One property of buffered I/O operations is the sample mode. The sample mode can be either finite or continuous:

- Finite sample mode acquisition refers to the acquisition of a specific, predetermined number of data samples. After the specified number of samples has been read in, the acquisition stops. If you use a reference trigger, you must use finite sample mode.
- Continuous acquisition refers to the acquisition of an unspecified number of samples. Instead of acquiring a set number of data samples and stopping, a continuous acquisition continues until you stop the operation. Continuous acquisition is also referred to as double-buffered or circular-buffered acquisition.

If data cannot be transferred across the bus fast enough, the FIFO becomes full. New acquisitions will overwrite data in the FIFO before it can be transferred to host memory. The device generates an error in this case. With continuous operations, if the user program does not read data out of the PC buffer fast enough to keep up with the data transfer, the buffer could reach an overflow condition, causing an error to be generated.

Analog Input Digital Triggering

Analog input supports three different triggering actions:

- Start trigger
- Reference trigger
- Pause trigger

Refer to the *AI Start Trigger Signal*, *AI Reference Trigger Signal*, and *AI Pause Trigger Signal* sections for information about these triggers.

A digital trigger can initiate these actions. All USB-621x devices support digital triggering. USB-621x devices do not support analog triggering.

Field Wiring Considerations

Environmental noise can seriously affect the measurement accuracy of the device if you do not take proper care when running signal wires between signal sources and the device. The following recommendations apply mainly to AI signal routing to the device, although they also apply to signal routing in general.

Minimize noise pickup and maximize measurement accuracy by taking the following precautions:

- Use differential AI connections to reject common-mode noise.
- Use individually shielded, twisted-pair wires to connect AI signals to the device. With this type of wire, the signals attached to the positive and negative input channels are twisted together and then covered with a shield. You then connect this shield only at one point to the signal source ground. This kind of connection is required for signals traveling through areas with large magnetic fields or high electromagnetic interference.

Refer to the NI Developer Zone document, *Field Wiring and Noise Considerations for Analog Signals*, for more information. To access this document, go to ni.com/info and enter the info code `rdfwn3`.



Caution Electromagnetic interference can adversely affect the measurement accuracy of this product. Refer to the *NI USB-621x Specifications* for more information about the performance of this product.

Analog Input Timing Signals

In order to provide all of the timing functionality described throughout this section, USB-621x devices have a flexible timing engine. Figure 4-4 summarizes all of the timing options provided by the analog input timing engine.

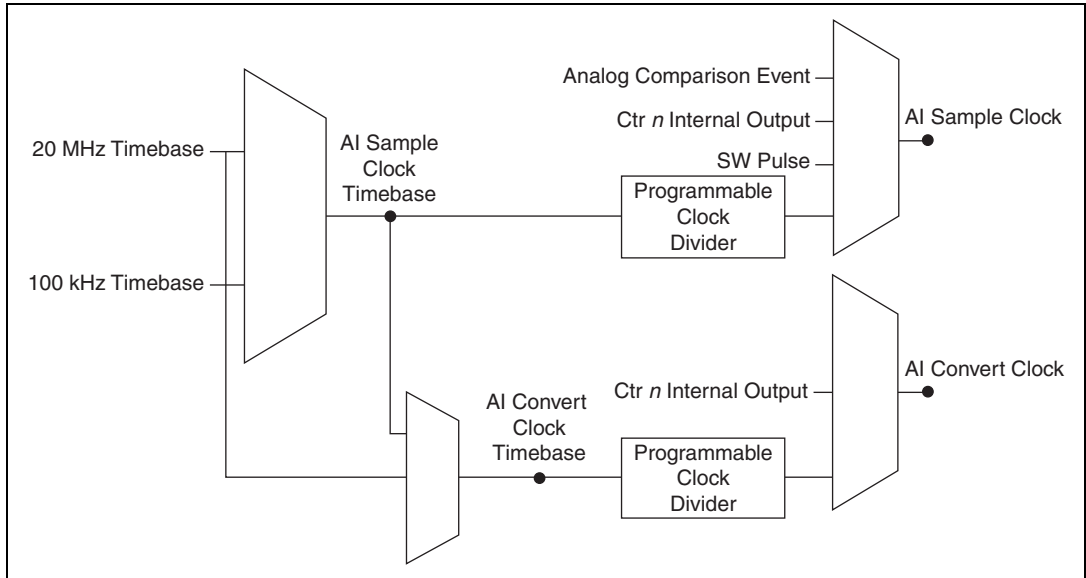

Figure 4-4. Analog Input Timing Options

USB-621x devices use AI Sample Clock (ai/SampleClock) and AI Convert Clock (ai/ConvertClock) to perform interval sampling. As Figure 4-5 shows, AI Sample Clock controls the sample period, which is determined by the following equation:

$$1/\text{Sample Period} = \text{Sample Rate}$$

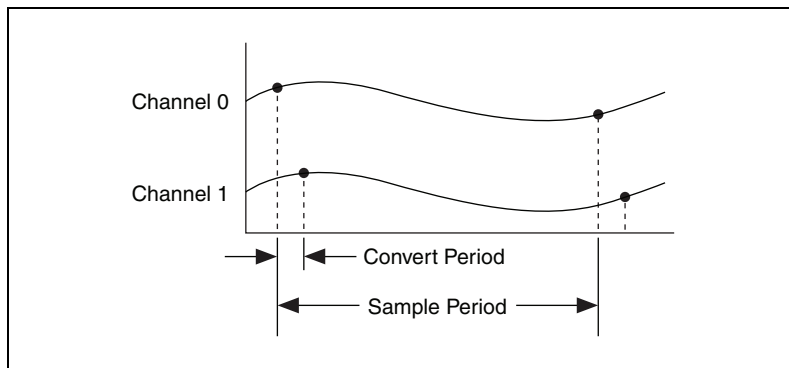

Figure 4-5. Interval Sampling

AI Convert Clock controls the Convert Period, which is determined by the following equation:

$$1/\text{Convert Period} = \text{Convert Rate}$$



Note The sampling rate is the fastest you can acquire data on the device and still achieve accurate results. For example, if a USB-621x device has a sampling rate of 250 kS/s, this sampling rate is aggregate—one channel at 250 kS/s or two channels at 125 kS/s per channel illustrates the relationship.

Posttriggered data acquisition allows you to view only data that is acquired after a trigger event is received. A typical posttriggered DAQ sequence is shown in Figure 4-6. The sample counter is loaded with the specified number of posttrigger samples, in this example, five. The value decrements with each pulse on AI Sample Clock, until the value reaches zero and all desired samples have been acquired.

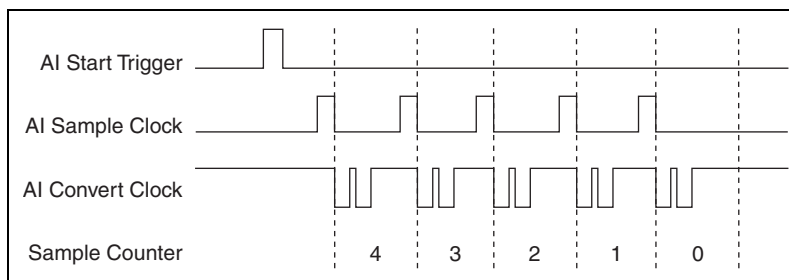

Figure 4-6. Posttriggered Data Acquisition Example

Pretriggered data acquisition allows you to view data that is acquired before the trigger of interest, in addition to data acquired after the trigger.

Figure 4-7 shows a typical pretriggered DAQ sequence. AI Start Trigger (ai/StartTrigger) can be either a hardware or software signal. If AI Start Trigger is set up to be a software start trigger, an output pulse appears on the AI Start Trigger line when the acquisition begins. When the AI Start Trigger pulse occurs, the sample counter is loaded with the number of pretriggered samples, in this example, four. The value decrements with each pulse on AI Sample Clock, until the value reaches zero. The sample counter is then loaded with the number of posttriggered samples, in this example, three.

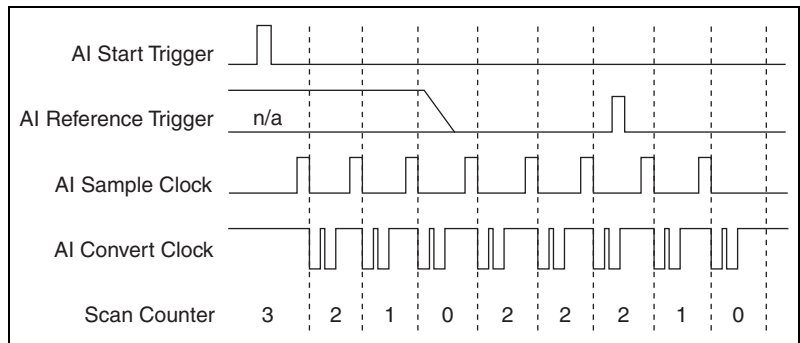

Figure 4-7. Pretriggered Data Acquisition Example

If an AI Reference Trigger (ai/ReferenceTrigger) pulse occurs before the specified number of pretrigger samples are acquired, the trigger pulse is ignored. Otherwise, when the AI Reference Trigger pulse occurs, the sample counter value decrements until the specified number of posttrigger samples have been acquired.

USB-621x devices feature the following analog input timing signals:

- *AI Sample Clock Signal*
- *AI Sample Clock Timebase Signal*
- *AI Convert Clock Signal*
- *AI Convert Clock Timebase Signal*
- *AI Hold Complete Event Signal*
- *AI Start Trigger Signal*
- *AI Reference Trigger Signal*
- *AI Pause Trigger Signal*

AI Sample Clock Signal

Use the AI Sample Clock (ai/SampleClock) signal to initiate a set of measurements. Your USB-621x device samples the AI signals of every channel in the task once for every AI Sample Clock. A measurement acquisition consists of one or more samples.

You can specify an internal or external source for AI Sample Clock. You also can specify whether the measurement sample begins on the rising edge or falling edge of AI Sample Clock.

Using an Internal Source

One of the following internal signals can drive AI Sample Clock:

- Counter n Internal Output
- AI Sample Clock Timebase (divided down)
- A pulse initiated by host software

A programmable internal counter divides down the sample clock timebase.

Using an External Source

Use any input PFI line as the source of AI Sample Clock.

Routing AI Sample Clock to an Output Terminal

You can route AI Sample Clock out to any output PFI terminal. This pulse is always active high.

You can specify the output to have one of two behaviors. With the pulse behavior, your DAQ device briefly pulses the PFI terminal once for every occurrence of AI Sample Clock.

With level behavior, your DAQ device drives the PFI terminal high during the entire sample.

Other Timing Requirements

Your DAQ device only acquires data during an acquisition. The device ignores AI Sample Clock when a measurement acquisition is not in progress. During a measurement acquisition, you can cause your DAQ device to ignore AI Sample Clock using the AI Pause Trigger signal.

A counter on your device internally generates AI Sample Clock unless you select some external source. AI Start Trigger starts this counter and either

software or hardware can stop it once a finite acquisition completes. When using an internally generated AI Sample Clock, you also can specify a configurable delay from AI Start Trigger to the first AI Sample Clock pulse. By default, this delay is set to two ticks of the AI Sample Clock Timebase signal. When using an externally generated AI Sample Clock, you must ensure the clock signal is consistent with respect to the timing requirements of AI Convert Clock. Failure to do so may result in AI Sample Clock pulses that are masked off and acquisitions with erratic sampling intervals. Refer to the *AI Convert Clock Signal* section for more information about the timing requirements between AI Convert Clock and AI Sample Clock.

Figure 4-8 shows the relationship of AI Sample Clock to AI Start Trigger.

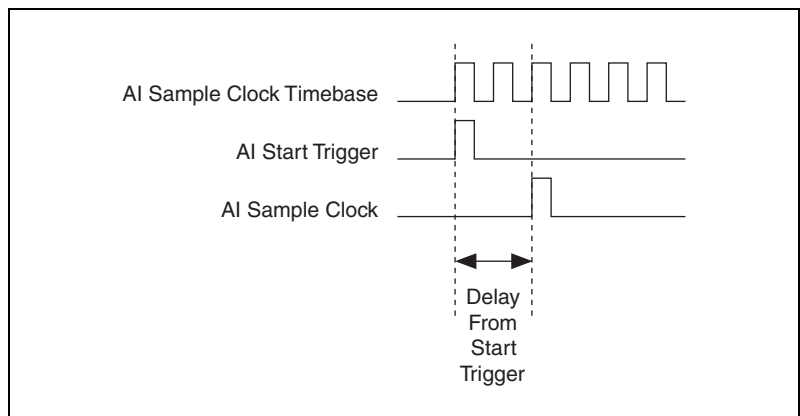

Figure 4-8. AI Sample Clock and AI Start Trigger

AI Sample Clock Timebase Signal

You can route any of the following signals to be the AI Sample Clock Timebase (`ai/SampleClockTimebase`) signal:

- 20 MHz Timebase
- 100 kHz Timebase
- **(USB-6210/6211/6215 Devices)** PFI <0..3>
- **(USB-6212/6216 Devices)** PFI <0..15>
- **(USB-6218 Devices)** PFI <0..3>, PFI <8..11>

AI Sample Clock Timebase is not available as an output on the I/O connector. AI Sample Clock Timebase is divided down to provide one of the possible sources for AI Sample Clock. You can configure the polarity selection for AI Sample Clock Timebase as either rising or falling edge.

AI Convert Clock Signal

Use the AI Convert Clock (ai/ConvertClock) signal to initiate a single A/D conversion on a single channel. A sample (controlled by the AI Sample Clock) consists of one or more conversions.

You can specify either an internal or external signal as the source of AI Convert Clock. You also can specify whether the measurement sample begins on the rising edge or falling edge of AI Convert Clock.

By default, NI-DAQmx chooses the fastest conversion rate possible based on the speed of the A/D converter and adds 10 μ s of padding between each channel to allow for adequate settling time. This scheme enables the channels to approximate simultaneous sampling and still allow for adequate settling time. If the AI Sample Clock rate is too fast to allow for this 10 μ s of padding, NI-DAQmx chooses the conversion rate so that the AI Convert Clock pulses are evenly spaced throughout the sample.

To explicitly specify the conversion rate, use **AI Convert Clock Rate DAQmx Timing** property node or function.



Caution Setting the conversion rate higher than the maximum rate specified for your device will result in errors.

Using an Internal Source

One of the following internal signals can drive AI Convert Clock:

- AI Convert Clock Timebase (divided down)
- Counter n Internal Output

A programmable internal counter divides down the AI Convert Clock Timebase to generate AI Convert Clock. Started by AI Sample Clock, the counter counts down to zero, produces an AI Convert Clock, reloads itself, and repeats the process until the sample is finished. It then reloads itself in preparation for the next AI Sample Clock pulse.

Using an External Source

Use any input PFI line as the source of AI Convert Clock.

Routing AI Convert Clock to an Output Terminal

You can route AI Convert Clock (as an active low signal) out to any output PFI terminal.

Using a Delay from Sample Clock to Convert Clock

When using an internally generated AI Convert Clock, you also can specify a configurable delay from AI Sample Clock to the first AI Convert Clock pulse within the sample. By default, this delay is three ticks of AI Convert Clock Timebase.

Figure 4-9 shows the relationship of AI Sample Clock to AI Convert Clock.

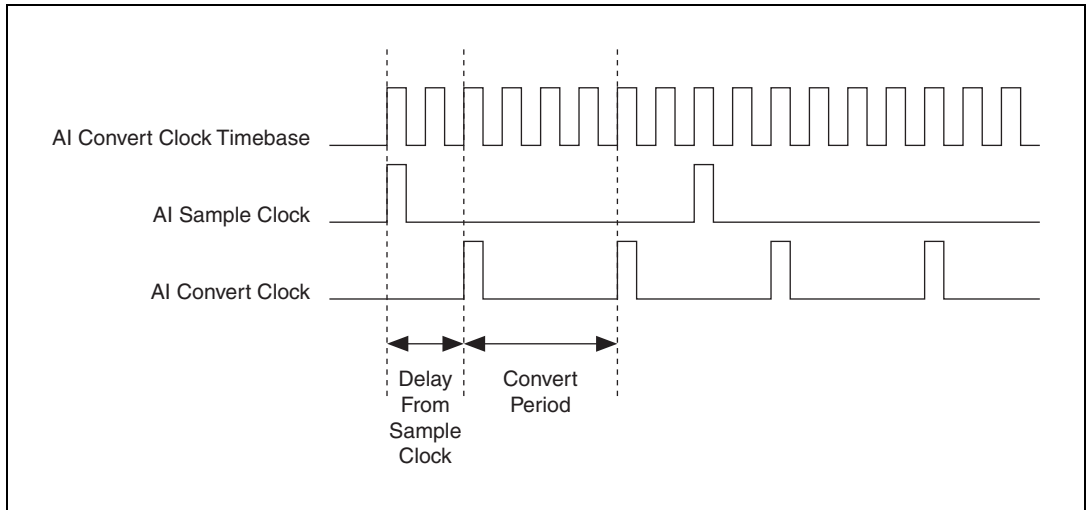

Figure 4-9. AI Sample Clock and AI Convert Clock

Other Timing Requirements

The sample and conversion level timing of USB-621x devices work such that clock signals are gated off unless the proper timing requirements are met. For example, the device ignores both AI Sample Clock and AI Convert Clock until it receives a valid AI Start Trigger signal. Once the device recognizes an AI Sample Clock pulse, it ignores subsequent AI Sample Clock pulses until it receives the correct number of AI Convert Clock pulses.

Similarly, the device ignores all AI Convert Clock pulses until it recognizes an AI Sample Clock pulse. Once the device receives the correct number of AI Convert Clock pulses, it ignores subsequent AI Convert Clock pulses until it receives another AI Sample Clock. Figures 4-10, 4-11, 4-12, and 4-13 show timing sequences for a four-channel acquisition (using AI channels 0, 1, 2, and 3) and demonstrate proper and improper sequencing of AI Sample Clock and AI Convert Clock.

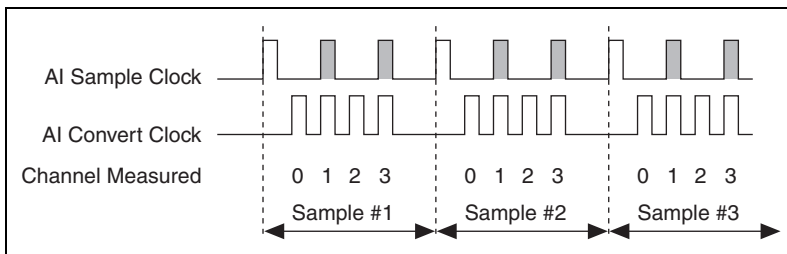

Figure 4-10. AI Sample Clock Too Fast For AI Convert Clock; AI Sample Clock Pulses Are Gated Off

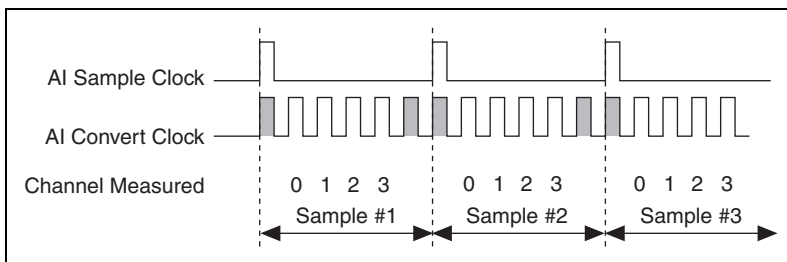

Figure 4-11. AI Convert Clock Too Fast For AI Sample Clock; AI Convert Clock Pulses Are Gated Off

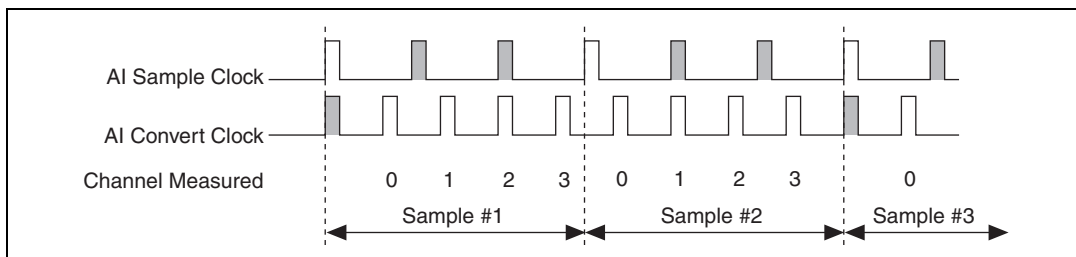

Figure 4-12. AI Sample Clock and AI Convert Clock Improperly Matched; Leads To Aperiodic Sampling

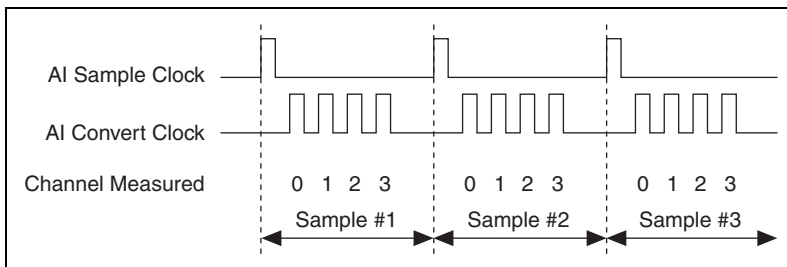

Figure 4-13. AI Sample Clock and AI Convert Clock Properly Matched

A single external signal can drive both AI Sample Clock and AI Convert Clock at the same time. In this mode, each tick of the external clock causes a conversion on the ADC. Figure 4-14 shows this timing relationship.

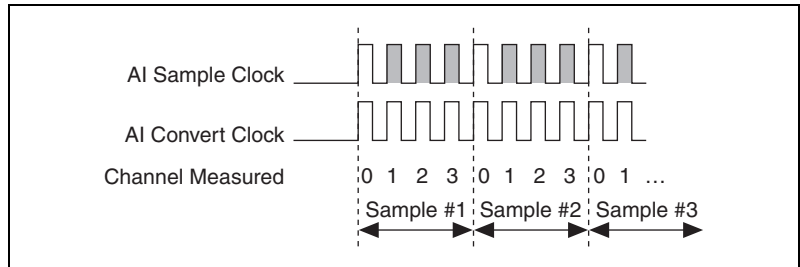

Figure 4-14. Single External Signal Driving AI Sample Clock and AI Convert Clock Simultaneously

AI Convert Clock Timebase Signal

The AI Convert Clock Timebase (`ai/ConvertClockTimebase`) signal is divided down to provide one of the possible sources for AI Convert Clock. Use one of the following signals as the source of AI Convert Clock Timebase:

- AI Sample Clock Timebase
- 20 MHz Timebase

AI Convert Clock Timebase is not available as an output on the I/O connector.

AI Hold Complete Event Signal

The AI Hold Complete Event (`ai/HoldCompleteEvent`) signal generates a pulse after each A/D conversion begins. You can route AI Hold Complete Event out to any output PFI terminal.

The polarity of AI Hold Complete Event is software-selectable, but is typically configured so that a low-to-high leading edge can clock external AI multiplexers indicating when the input signal has been sampled and can be removed.

AI Start Trigger Signal

Use the AI Start Trigger (ai/StartTrigger) signal to begin a measurement acquisition. A measurement acquisition consists of one or more samples. If you do not use triggers, begin a measurement with a software command. After the acquisition begins, configure the acquisition to stop:

- When a certain number of points are sampled (in finite mode)
- After a hardware reference trigger (in finite mode)
- With a software command (in continuous mode)

An acquisition that uses a start trigger (but not a reference trigger) is sometimes referred to as a posttriggered acquisition.

Using a Digital Source

To use AI Start Trigger with a digital source, specify a source and an edge. The source can be any of the following signals:

- **(USB-6210/6211/6215 Devices)** PFI <0..3>
- **(USB-6212/6216 Devices)** PFI <0..15>
- **(USB-6218 Devices)** PFI <0..3>, PFI <8..11>
- Counter n Internal Output

The source also can be one of several other internal signals on your DAQ device. Refer to *Device Routing in MAX* in the *NI-DAQmx Help* or the *LabVIEW Help* in version 8.0 or later for more information.

You also can specify whether the measurement acquisition begins on the rising edge or falling edge of AI Start Trigger.

Routing AI Start Trigger to an Output Terminal

You can route AI Start Trigger out to any output PFI terminal.

The output is an active high pulse.

The device also uses AI Start Trigger to initiate pretriggered DAQ operations. In most pretriggered applications, a software trigger generates AI Start Trigger. Refer to the *AI Reference Trigger Signal* section for a complete description of the use of AI Start Trigger and AI Reference Trigger in a pretriggered DAQ operation.

AI Reference Trigger Signal

Use a reference trigger (`ai/ReferenceTrigger`) signal to stop a measurement acquisition. To use a reference trigger, specify a buffer of finite size and a number of pretrigger samples (samples that occur before the reference trigger). The number of posttrigger samples (samples that occur after the reference trigger) desired is the buffer size minus the number of pretrigger samples.

After the acquisition begins, the DAQ device writes samples to the buffer. After the DAQ device captures the specified number of pretrigger samples, the DAQ device begins to look for the reference trigger condition. If the reference trigger condition occurs before the DAQ device captures the specified number of pretrigger samples, the DAQ device ignores the condition.

If the buffer becomes full, the DAQ device continuously discards the oldest samples in the buffer to make space for the next sample. This data can be accessed (with some limitations) before the DAQ device discards it. Refer to the KnowledgeBase document, *Can a Pretriggered Acquisition be Continuous?*, for more information. To access this KnowledgeBase, go to `ni.com/info` and enter the info code `rdcanq`.

When the reference trigger occurs, the DAQ device continues to write samples to the buffer until the buffer contains the number of posttrigger samples desired. Figure 4-15 shows the final buffer.

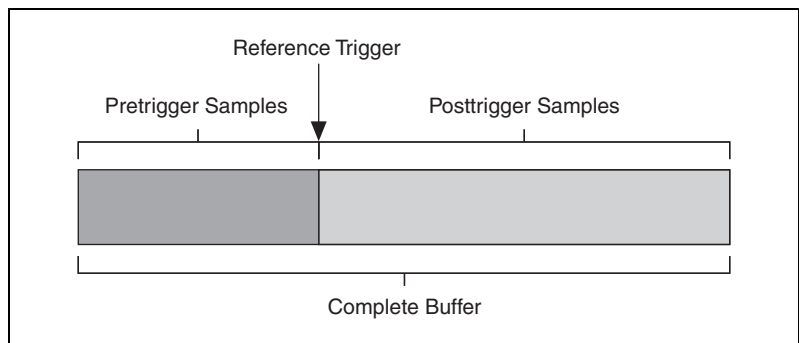

Figure 4-15. Reference Trigger Final Buffer

Using a Digital Source

To use AI Reference Trigger with a digital source, specify a source and an edge. The source can be any input PFI signal.

The source also can be one of several internal signals on your DAQ device. Refer to *Device Routing in MAX* in the *NI-DAQmx Help* or the *LabVIEW Help* in version 8.0 or later for more information.

You also can specify whether the measurement acquisition stops on the rising edge or falling edge of AI Reference Trigger.

Routing AI Reference Trigger to an Output Terminal

You can route AI Reference Trigger out to any output PFI terminal.

AI Pause Trigger Signal

You can use the AI Pause Trigger (ai/PauseTrigger) signal to pause and resume a measurement acquisition. The internal sample clock pauses while the external trigger signal is active and resumes when the signal is inactive. You can program the active level of the pause trigger to be high or low.

Using a Digital Source

To use AI Sample Clock, specify a source and a polarity. The source can be any input PFI signal.

The source also can be one of several other internal signals on your DAQ device. Refer to *Device Routing in MAX* in the *NI-DAQmx Help* or the *LabVIEW Help* in version 8.0 or later for more information.

Getting Started with AI Applications in Software

You can use the USB-621x device in the following analog input applications:

- Single-point analog input
- Finite analog input
- Continuous analog input

You can perform these applications through DMA, interrupt, or programmed I/O data transfer mechanisms. Some of the applications also use start, reference, and pause triggers.



Note For more information about programming analog input applications and triggers in software, refer to the *NI-DAQmx Help* or the *LabVIEW Help* in version 8.0 or later.

Connecting Analog Input Signals on USB-6210/6211/6212 Devices

Table 4-2 summarizes the recommended input configuration for both types of signal sources on USB-6210/6211/6212 devices.

Table 4-2. USB-6210/6211/6212 Analog Input Configuration

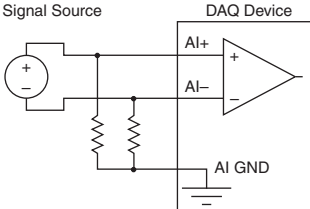
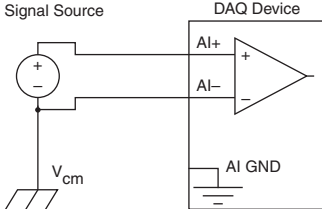
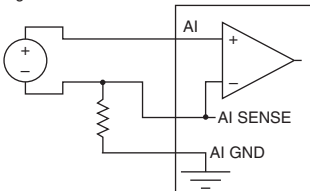
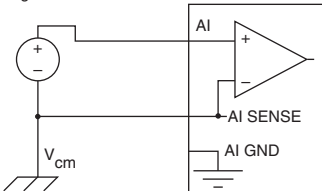
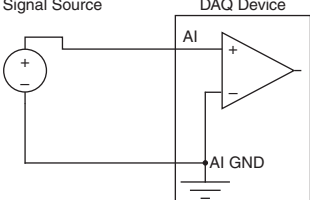
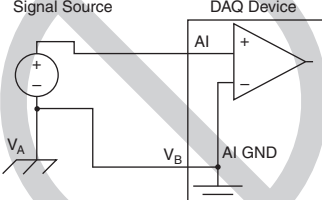
AI Ground-Reference Setting*	Floating Signal Sources (Not Connected to Building Ground)	Ground-Referenced Signal Sources†
	Examples: <ul style="list-style-type: none"> • Ungrounded thermocouples • Signal conditioning with isolated outputs • Battery devices 	Example: <ul style="list-style-type: none"> • Plug-in instruments with non-isolated outputs
Differential (DIFF)		
Non-Referenced Single-Ended (NRSE)		
Referenced Single-Ended (RSE)		<p style="text-align: center;">NOT RECOMMENDED for the USB-6210/6211/6212</p>  <p style="text-align: center;">Ground-loop potential ($V_A - V_B$) are added to measured signal.</p>
<p>* Refer to the Analog Input Ground-Reference Settings section for descriptions of the RSE, NRSE, and DIFF modes and software considerations.</p> <p>† Refer to the Connecting Ground-Referenced Signal Sources section for more information.</p> <p>Note: (USB-621x BNC Devices) Refer to the appropriate Analog Input section for your USB-621x BNC device in Appendix A, Device-Specific Information, for more information about using grounded and floating signal sources with your device.</p>		

Connecting Floating Signal Sources

What Are Floating Signal Sources?

A floating signal source is not connected to the building ground system, but has an isolated ground-reference point. Some examples of floating signal sources are outputs of transformers, thermocouples, battery-powered devices, optical isolators, and isolation amplifiers. An instrument or device that has an isolated output is a floating signal source.

When to Use Differential Connections with Floating Signal Sources

Use differential input connections for any channel that meets any of the following conditions:

- The input signal is low level (less than 1 V).
- The leads connecting the signal to the device are greater than 3 m (10 ft).
- The input signal requires a separate ground-reference point or return signal.
- The signal leads travel through noisy environments.
- Two analog input channels, AI+ and AI–, are available for the signal.

Differential signal connections reduce noise pickup and increase common-mode noise rejection. Differential signal connections also allow input signals to float within the common-mode limits of the NI-PGIA.

Refer to the [Using Differential Connections for Floating Signal Sources](#) section for more information about differential connections.

When to Use Referenced Single-Ended Connections with Floating Signal Sources

Only use referenced single-ended input connections if the input signal meets the following conditions:

- The input signal can share a common reference point, AI GND, with other signals that use referenced single-ended.
- The input signal is high-level (greater than 1 V).
- The leads connecting the signal to the device are less than 3 m (10 ft).

Differential input connections are recommended for greater signal integrity for any input signal that does not meet the preceding conditions.

In the single-ended modes, more electrostatic and magnetic noise couples into the signal connections than in differential configurations. The coupling is the result of differences in the signal path. Magnetic coupling is proportional to the area between the two signal conductors. Electrical coupling is a function of how much the electric field differs between the two conductors.

With this type of connection, the NI-PGIA rejects both the common-mode noise in the signal and the ground potential difference between the signal source and the device ground.

Refer to the [Using Referenced Single-Ended Connections for Floating Signal Sources](#) section for more information about referenced single-ended connections.

When to Use Non-Referenced Single-Ended Connections with Floating Signal Sources

Only use non-referenced single-ended input connections if the input signal meets the following conditions:

- The input signal is high-level (greater than 1 V).
- The leads connecting the signal to the device are less than 3 m (10 ft).

Differential input connections are recommended for greater signal integrity for any input signal that does not meet the preceding conditions.

In the single-ended modes, more electrostatic and magnetic noise couples into the signal connections than in differential configurations. The coupling is the result of differences in the signal path. Magnetic coupling is proportional to the area between the two signal conductors. Electrical coupling is a function of how much the electric field differs between the two conductors.

With this type of connection, the NI-PGIA rejects both the common-mode noise in the signal and the ground potential difference between the signal source and the device ground.

Refer to the [Using Non-Referenced Single-Ended Connections for Floating Signal Sources](#) section for more information about non-referenced single-ended connections.

Using Differential Connections for Floating Signal Sources

It is important to connect the negative lead of a floating source to AI GND (either directly or through a bias resistor). Otherwise, the source may float out of the maximum working voltage range of the NI-PGIA and the DAQ device returns erroneous data.

The easiest way to reference the source to AI GND is to connect the positive side of the signal to AI+ and connect the negative side of the signal to AI GND as well as to AI- without using resistors. This connection works well for DC-coupled sources with low source impedance (less than 100 Ω).

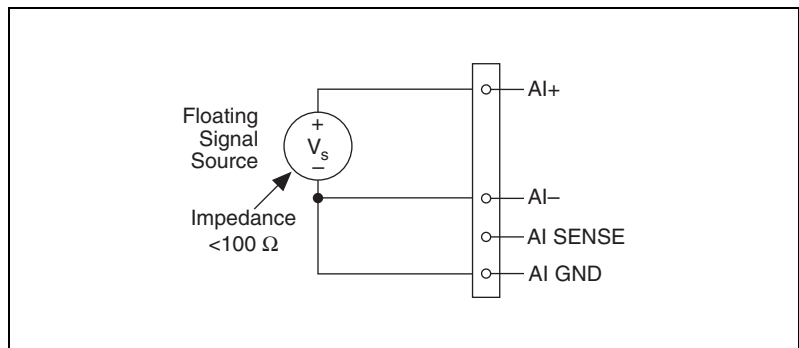

Figure 4-16. Differential Connections for Floating Signal Sources without Bias Resistors

However, for larger source impedances, this connection leaves the differential signal path significantly off balance. Noise that couples electrostatically onto the positive line does not couple onto the negative line because it is connected to ground. This noise appears as a differential mode signal instead of a common-mode signal, and thus appears in your data. In this case, instead of directly connecting the negative line to AI GND, connect the negative line to AI GND through a resistor that is about 100 times the equivalent source impedance. The resistor puts the signal path nearly in balance, so that about the same amount of noise couples onto both connections, yielding better rejection of electrostatically coupled noise. This configuration does not load down the source (other than the very high input impedance of the NI-PGIA).

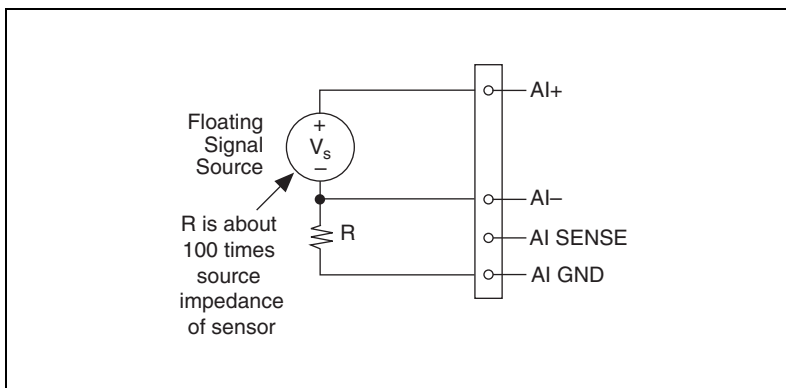

Figure 4-17. Differential Connections for Floating Signal Sources with Single Bias Resistor

You can fully balance the signal path by connecting another resistor of the same value between the positive input and AI GND on the USB-6210/6211/6212 device, as shown in Figure 4-18. This fully balanced configuration offers slightly better noise rejection, but has the disadvantage of loading the source down with the series combination (sum) of the two resistors. If, for example, the source impedance is $2\text{ k}\Omega$ and each of the two resistors is $100\text{ k}\Omega$, the resistors load down the source with $200\text{ k}\Omega$ and produce a -1% gain error.

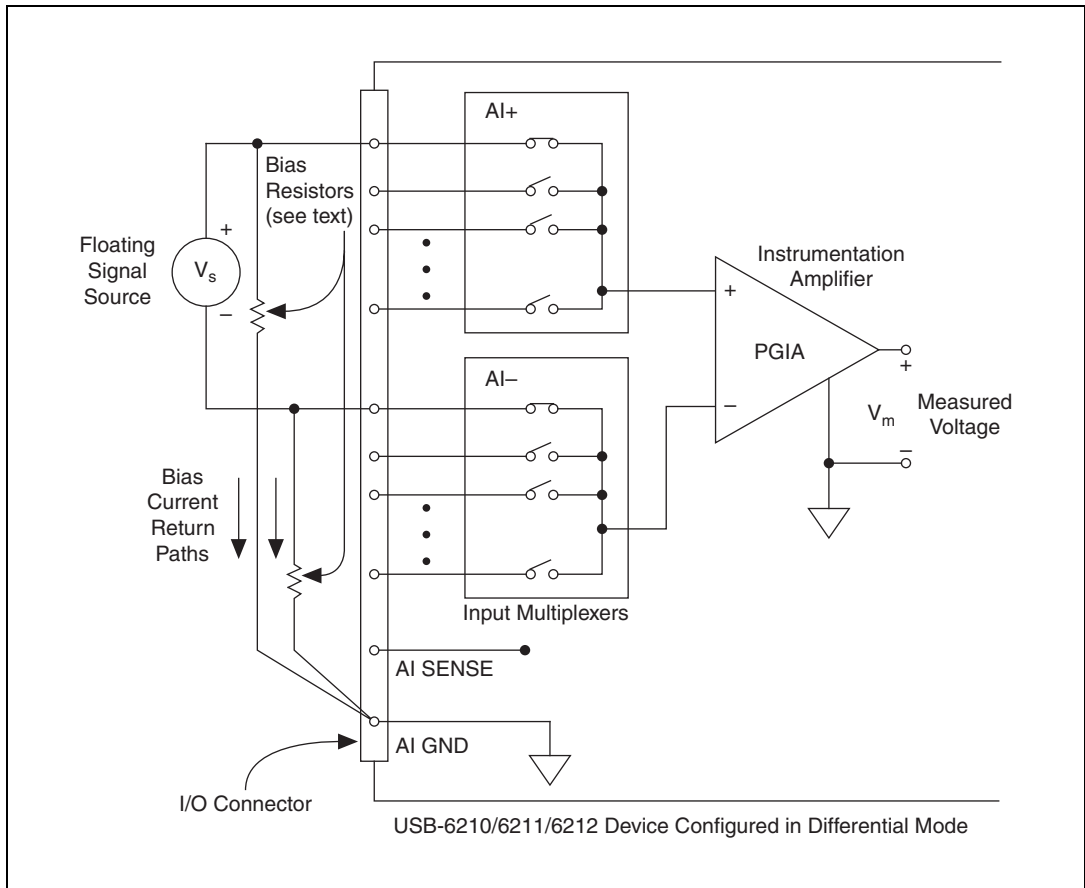

Figure 4-18. Differential Connections for Floating Signal Sources with Balanced Bias Resistors

Both inputs of the NI-PGIA require a DC path to ground in order for the NI-PGIA to work. If the source is AC coupled (capacitively coupled), the NI-PGIA needs a resistor between the positive input and AI GND. If the source has low-impedance, choose a resistor that is large enough not to significantly load the source, but small enough not to produce significant input offset voltage as a result of input bias current (typically 100 k Ω to 1 M Ω). In this case, connect the negative input directly to AI GND. If the source has high output impedance, balance the signal path as previously described using the same value resistor on both the positive and negative inputs; be aware that there is some gain error from loading down the source, as shown in Figure 4-19.

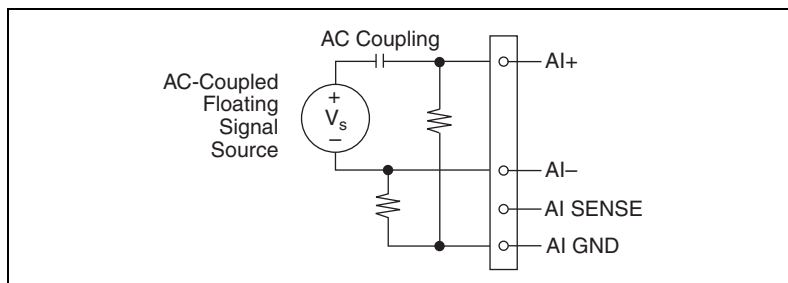

Figure 4-19. Differential Connections for AC Coupled Floating Sources with Balanced Bias Resistors

Using Non-Referenced Single-Ended Connections for Floating Signal Sources

It is important to connect the negative lead of a floating signals source to AI GND (either directly or through a resistor). Otherwise, the source may float out of the valid input range of the NI-PGIA and the DAQ device returns erroneous data.

Figure 4-20 shows a floating source connected to the DAQ device in non-referenced single-ended mode.

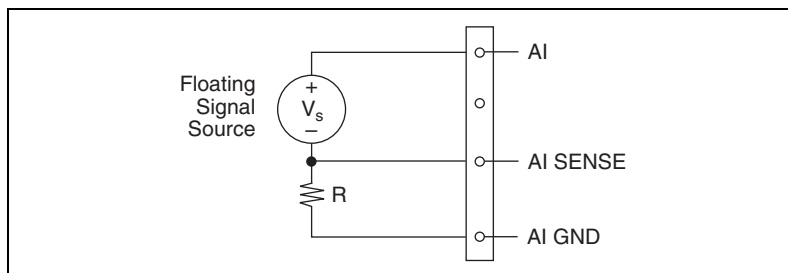

Figure 4-20. Non-Referenced Single-Ended Connections for Floating Signal Sources

All of the bias resistor configurations discussed in the [Using Differential Connections for Floating Signal Sources](#) section apply to the non-referenced single-ended bias resistors as well. Replace AI- with AI SENSE in Figures 4-16, 4-17, 4-18, and 4-19 for configurations with zero to two bias resistors. The noise rejection of non-referenced single-ended mode is better than referenced single-ended mode because the AI SENSE connection is made remotely near the source. However, the noise rejection of non-referenced single-ended mode is worse than differential mode because the AI SENSE connection is shared with all channels rather than being cabled in a twisted pair with the AI+ signal.

Using the DAQ Assistant, you can configure the channels for referenced single-ended or non-referenced single-ended input modes. Refer to the [Configuring AI Ground-Reference Settings in Software](#) section for more information about the DAQ Assistant.

Using Referenced Single-Ended Connections for Floating Signal Sources

Figure 4-21 shows how to connect a floating signal source to the USB-6210/6211/6212 device configured for referenced single-ended mode.

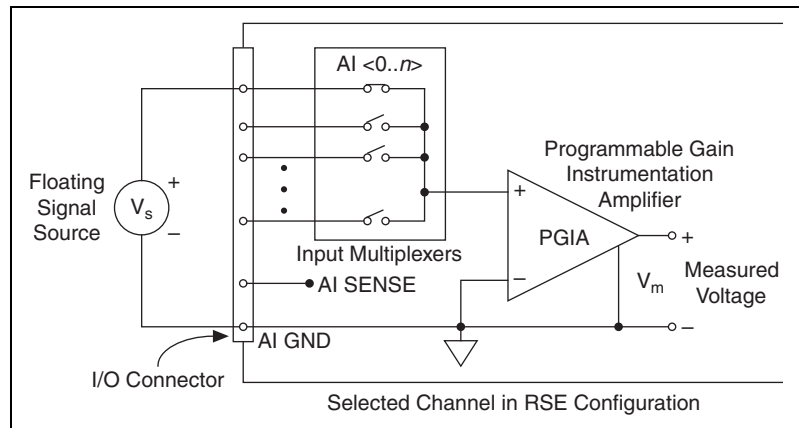

Figure 4-21. Referenced Single-Ended Connections for Floating Signal Sources

Using the DAQ Assistant, you can configure the channels for referenced single-ended or non-referenced single-ended input modes. Refer to the [Configuring AI Ground-Reference Settings in Software](#) section for more information about the DAQ Assistant.

Connecting Ground-Referenced Signal Sources

What Are Ground-Referenced Signal Sources?

A ground-referenced signal source is a signal source connected to the building system ground. It is already connected to a common ground point with respect to the device, assuming that the computer is plugged into the same power system as the source. Non-isolated outputs of instruments and devices that plug into the building power system fall into this category.

The difference in ground potential between two instruments connected to the same building power system is typically between 1 and 100 mV, but the difference can be much higher if power distribution circuits are improperly connected. If a grounded signal source is incorrectly measured, this difference can appear as measurement error. Follow the connection instructions for grounded signal sources to eliminate this ground potential difference from the measured signal.

When to Use Differential Connections with Ground-Referenced Signal Sources

Use differential input connections for any channel that meets any of the following conditions:

- The input signal is low level (less than 1 V).
- The leads connecting the signal to the device are greater than 3 m (10 ft).
- The input signal requires a separate ground-reference point or return signal.
- The signal leads travel through noisy environments.
- Two analog input channels, AI+ and AI-, are available.

Differential signal connections reduce noise pickup and increase common-mode noise rejection. Differential signal connections also allow input signals to float within the common-mode limits of the NI-PGIA.

Refer to the [Using Differential Connections for Ground-Referenced Signal Sources](#) section for more information about differential connections.

When to Use Non-Referenced Single-Ended Connections with Ground-Referenced Signal Sources

Only use non-referenced single-ended input connections if the input signal meets the following conditions:

- The input signal is high-level (greater than 1 V).
- The leads connecting the signal to the device are less than 3 m (10 ft).
- The input signal can share a common reference point with other signals.

Differential input connections are recommended for greater signal integrity for any input signal that does not meet the preceding conditions.

In the single-ended modes, more electrostatic and magnetic noise couples into the signal connections than in differential configurations. The coupling is the result of differences in the signal path. Magnetic coupling is proportional to the area between the two signal conductors. Electrical coupling is a function of how much the electric field differs between the two conductors.

With this type of connection, the NI-PGIA rejects both the common-mode noise in the signal and the ground potential difference between the signal source and the device ground.

Refer to the [Using Non-Referenced Single-Ended Connections for Ground-Referenced Signal Sources](#) section for more information about non-referenced single-ended connections.

When to Use Referenced Single-Ended Connections with Ground-Referenced Signal Sources

Do *not* use referenced single-ended connections with ground-referenced signal sources. Use non-referenced single-ended or differential connections instead.

As shown in the bottom-rightmost cell of Table 4-2, there can be a potential difference between AI GND and the ground of the sensor. In referenced single-ended mode, this ground loop causes measurement errors.

Using Differential Connections for Ground-Referenced Signal Sources

Figure 4-22 shows how to connect a ground-referenced signal source to the USB-6210/6211/6212 device configured in differential mode.

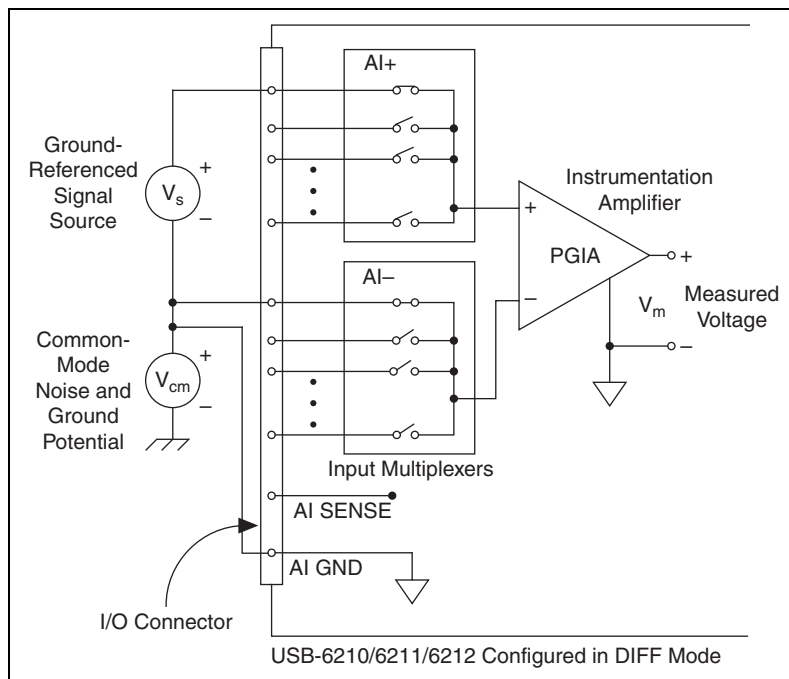

Figure 4-22. Differential Connections for Ground-Referenced Signal Sources

With this type of connection, the NI-PGIA rejects both the common-mode noise in the signal and the ground potential difference between the signal source and the device ground, shown as V_{cm} in the figure.

AI+ and AI- must both remain within ± 11 V of AI GND.

Using Non-Referenced Single-Ended Connections for Ground-Referenced Signal Sources

Figure 4-23 shows how to connect ground-reference signal sources to the USB-6210/6211/6212 device in non-referenced single-ended mode.

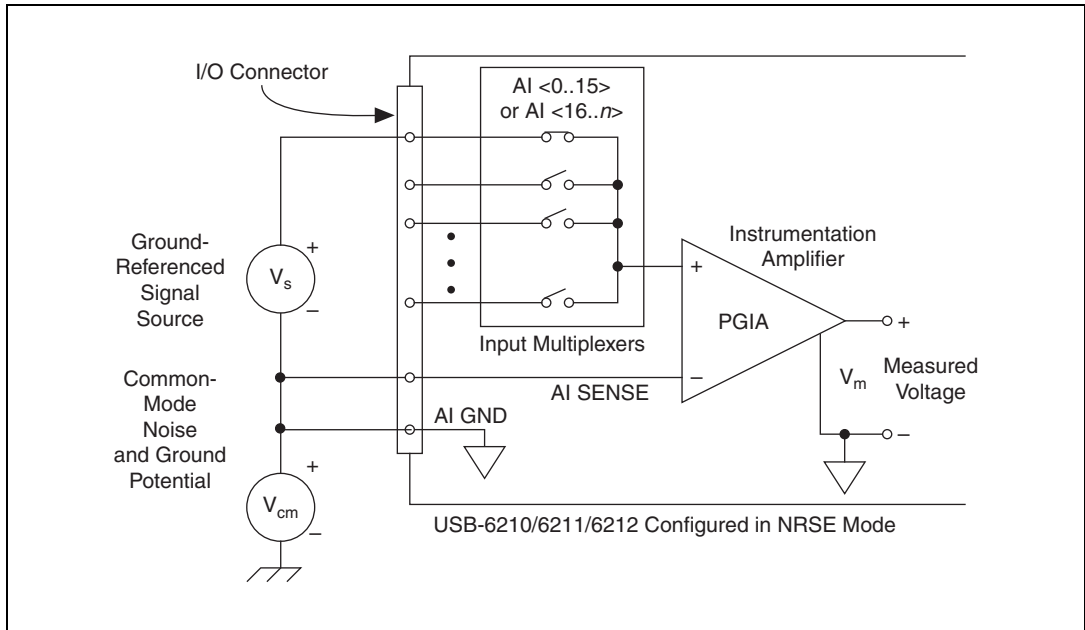

Figure 4-23. Single-Ended Connections for Ground-Referenced Signal Sources (NRSE Configuration)

AI+ and AI- must both remain within ± 11 V of AI GND.

To measure a single-ended, ground-referenced signal source, you must use the non-referenced single-ended ground-reference setting. Connect the signal to one of AI <0..31> and connect the signal local ground reference to AI SENSE. AI SENSE is internally connected to the negative input of the NI-PGIA. Therefore, the ground point of the signal connects to the negative input of the NI-PGIA.

Any potential difference between the device ground and the signal ground appears as a common-mode signal at both the positive and negative inputs of the NI-PGIA, and this difference is rejected by the amplifier. If the input circuitry of a device were referenced to ground, as it is in the referenced single-ended ground-reference setting, this difference in ground potentials would appear as an error in the measured voltage.

Using the DAQ Assistant, you can configure the channels for referenced single-ended or non-referenced single-ended input modes. Refer to the [Configuring AI Ground-Reference Settings in Software](#) section for more information about the DAQ Assistant.

Connecting Analog Input Signals on USB-6215/6216/6218 Devices

You can connect the USB-6215/6216/6218 directly to a variety of devices and other signal sources. Make sure the devices you connect to the USB-6215/6216/6218 are compatible with the input specifications of the module.

When connecting various sources to the USB-6215/6216/6218, you can use differential, single-ended, or a combination of single-ended and differential connections.



Note You must always connect AI GND to a local ground signal in your system using a low impedance connection. If you leave AI GND unconnected, you cannot ensure that AI <0..31> are within 10 V of AI GND, and your measurement may be unreliable.

Taking Differential Measurements

To attain more accurate measurements and less noise, use a differential measurement configuration. A differential measurement configuration requires two inputs for each measurement. The AI <0..31> description in Table 3-1, [I/O Connector Signals](#), lists the signal pairs that are valid for differential connection configurations with USB-621x devices.

Figure 4-24 shows a differential connection configuration.

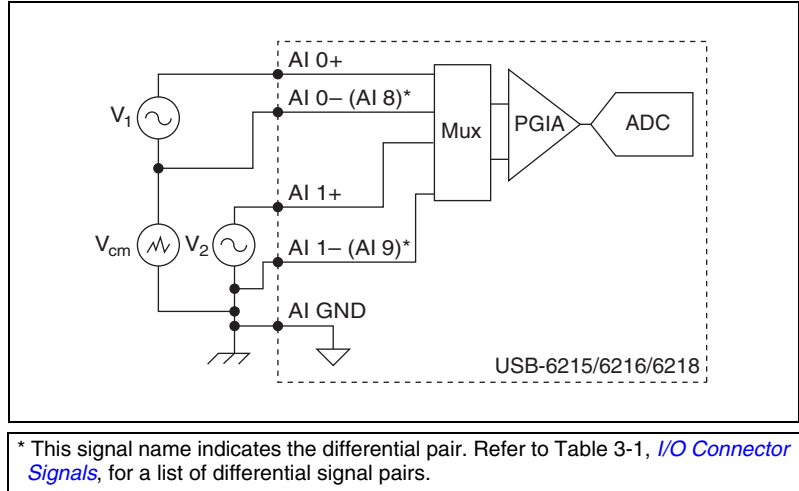

Figure 4-24. Connecting to the USB-6215/6216/6218 in Differential Mode

The differential connection configuration allows the common-mode noise voltage, V_{cm} , to be rejected during the measurement of V_1 .

You must connect the negative lead of your sensors and AI GND to a local ground signal on your system.

Taking Referenced Single-Ended Measurements

Using the referenced single-ended measurement configuration allows the USB-6215/6216/6218 to take measurements on all AI channels when all channels share a common ground. Figure 4-25 shows an referenced single-ended connection configuration.



Note If you leave the AI GND pin unconnected, the signals float outside the working input range of the USB-6215/6216/6218. This can result in unreliable measurements because you cannot ensure that the input signal is within 10 V of AI GND.

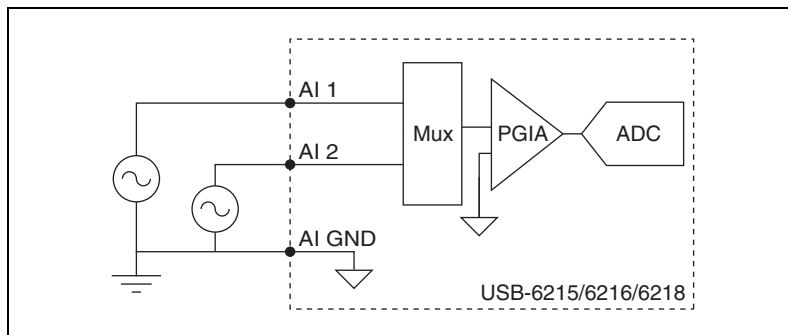

Figure 4-25. Connecting to the USB-6215/6216/6218 in Referenced Single-Ended Mode

In an referenced single-ended connection configuration, each input channel is measured with respect to AI GND.

Taking Non-Referenced Single-Ended Measurements

To reach a compromise between referenced single-ended and differential measurements, you can use an non-referenced single-ended measurement configuration. This configuration allows for a remote sense for the negative (–) input of the instrumentation amplifier (PGIA) that is shared among all channels configured for non-referenced single-ended mode. The behavior of this configuration is similar to that of referenced single-ended connections, except it provides improved noise rejection. Figure 4-26 shows an non-referenced single-ended connection configuration.

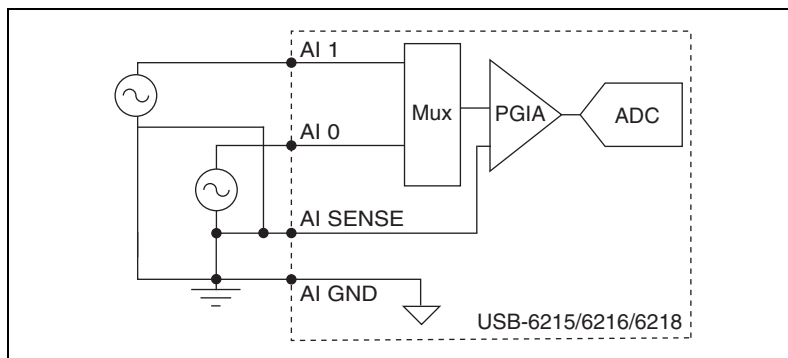

Figure 4-26. Connecting to the USB-6215/6216/6218 in Non-Referenced Single-Ended Mode

In non-referenced single-ended connection configuration, each input channel is measured with respect to AI SENSE.

Analog Output

Most USB-621x devices have analog output functionality. USB-621x devices that support analog output have two AO channels controlled by a single clock and capable of waveform generation. Refer to the *NI USB-621x Specifications* for information about your device capabilities.

Figure 5-1 shows the analog output circuitry of USB-621x devices.

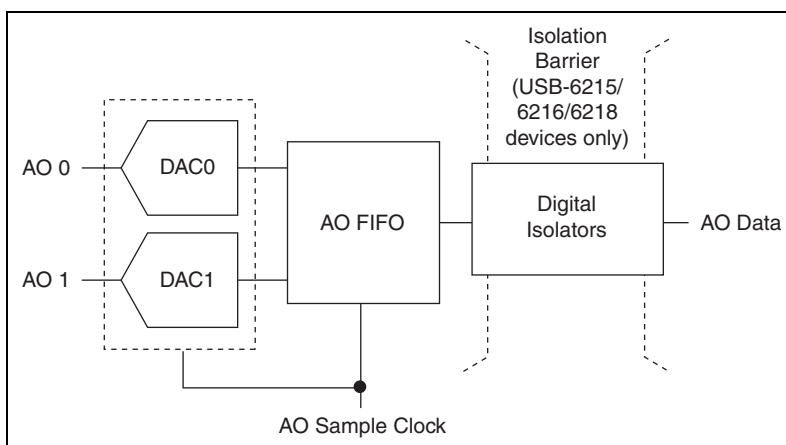

Figure 5-1. USB-621x Analog Output Circuitry

The main blocks featured in the USB-621x analog output circuitry are as follows:

- **DAC0 and DAC1**—Digital-to-analog converters (DACs) convert digital codes to analog voltages.
- **AO FIFO**—The AO FIFO enables analog output waveform generation. It is a first-in-first-out (FIFO) memory buffer between the computer and the DACs. It allows you to download the points of a waveform to your USB-621x device without host computer interaction.

- **AO Sample Clock**—The AO Sample Clock signal reads a sample from the DAC FIFO and generates the AO voltage. Refer to the [AO Sample Clock Signal](#) section for more information.
- **Isolation Barrier and Digital Isolators**—Refer to Chapter 9, [Isolation and Digital Isolators on USB-6215/6216/6218 Devices](#), for more information.

AO Range

The AO range is ± 10 V for USB-621x devices.

Minimizing Glitches on the Output Signal

When you use a DAC to generate a waveform, you may observe glitches on the output signal. These glitches are normal; when a DAC switches from one voltage to another, it produces glitches due to released charges. The largest glitches occur when the most significant bit of the DAC code changes. You can build a lowpass deglitching filter to remove some of these glitches, depending on the frequency and nature of the output signal. Visit ni.com/support for more information about minimizing glitches.

Analog Output Data Generation Methods

When performing an analog output operation, you can perform software-timed or hardware-timed generations:

- **Software-Timed Generations**—Software controls the rate at which data is generated. Software sends a separate command to the hardware to initiate each DAC conversion. In NI-DAQmx, software-timed generations are referred to as on-demand timing. Software-timed generations are also referred to as immediate or static operations. They are typically used for writing a single value out, such as a constant DC voltage.
- **Hardware-Timed Generations**—A digital hardware signal controls the rate of the generation. This signal can be generated internally on your device or provided externally.

Hardware-timed generations have several advantages over software-timed acquisitions:

- The time between samples can be much shorter.
- The timing between samples can be deterministic.

- Hardware-timed acquisitions can use hardware triggering.

Hardware-timed operations are buffered. During hardware-timed AO generation, data is moved from a PC buffer to the onboard FIFO on the USB-621x device using USB Signal Streams before it is written to the DACs one sample at a time. Buffered acquisitions allow for fast transfer rates because data is moved in large blocks rather than one point at a time.

One property of buffered I/O operations is the sample mode. The sample mode can be either finite or continuous:

- Finite sample mode generation refers to the generation of a specific, predetermined number of data samples. After the specified number of samples has been written out, the generation stops.
- Continuous generation refers to the generation of an unspecified number of samples. Instead of generating a set number of data samples and stopping, a continuous generation continues until you stop the operation. There are three methods of continuous generation that control what data is written. These methods are regeneration, FIFO regeneration, and non-regeneration modes.

Regeneration is the repetition of the data that is already in the buffer. Standard regeneration is when data from the PC buffer is continually downloaded to the FIFO to be written out. New data can be written to the PC buffer at any time without disrupting the output.

With FIFO regeneration, the entire buffer is downloaded to the FIFO and regenerated from there. Once the data is downloaded, new data cannot be written to the FIFO. To use FIFO regeneration, the entire buffer must fit within the FIFO size. The advantage of using FIFO regeneration is that it does not require communication with the main host memory once the operation is started, thereby preventing any problems that may occur due to excessive bus traffic.

With non-regeneration, old data is not repeated. New data must be continually written to the buffer. If the program does not write new data to the buffer at a fast enough rate to keep up with the generation, the buffer underflows and causes an error.

Analog Output Digital Triggering

Analog output supports two different triggering actions:

- Start trigger
- Pause trigger

A digital trigger can initiate these actions on USB-621x devices. Refer to the *AO Start Trigger Signal* and *AO Pause Trigger Signal* sections for more information about these triggering actions.

Connecting Analog Output Signals

AO <0..1> are the voltage output signals for AO channels 0 and 1.
AO GND is the ground reference for AO <0..1>.

Figure 5-2 shows how to make AO connections to the device.

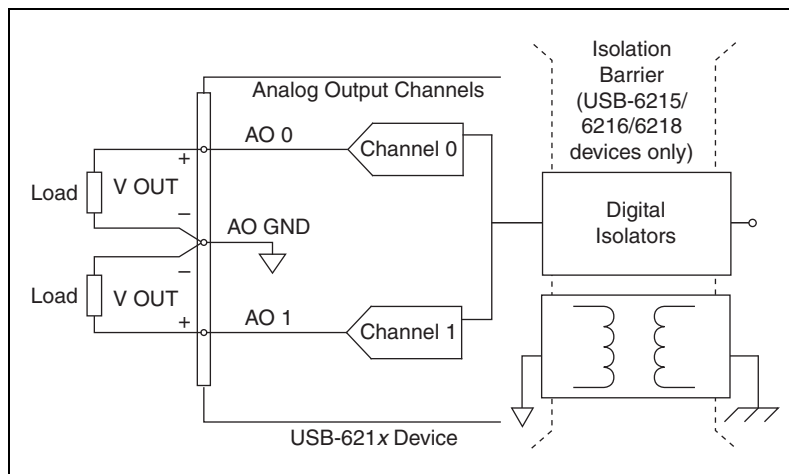

Figure 5-2. Analog Output Connections

Analog Output Timing Signals

Figure 5-3 summarizes all of the timing options provided by the analog output timing engine.

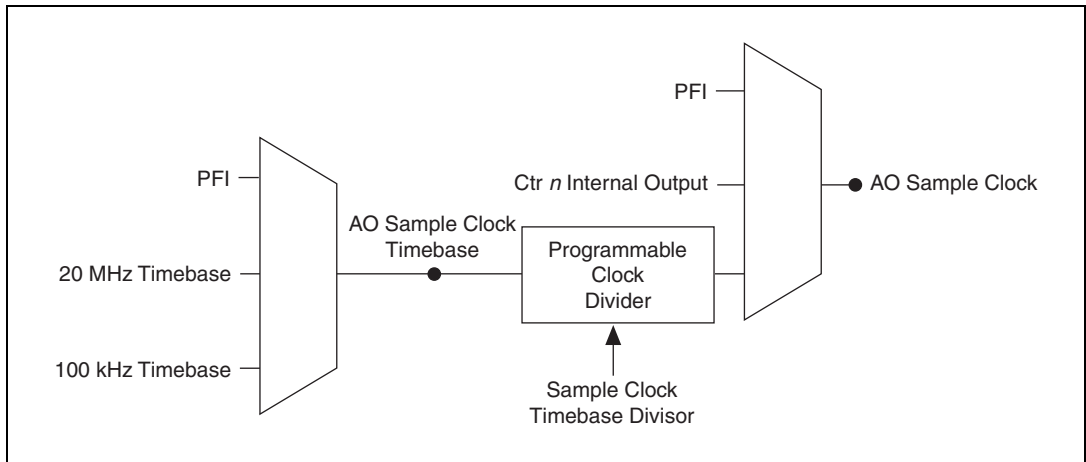

Figure 5-3. Analog Output Timing Options

USB-621x devices feature the following AO (waveform generation) timing signals:

- *AO Start Trigger Signal*
- *AO Pause Trigger Signal*
- *AO Sample Clock Signal*
- *AO Sample Clock Timebase Signal*

AO Start Trigger Signal

Use the AO Start Trigger (ao/StartTrigger) signal to initiate a waveform generation. If you do not use triggers, you can begin a generation with a software command.

Using a Digital Source

To use AO Start Trigger, specify a source and an edge. The source can be one of the following signals:

- A pulse initiated by host software
- **(USB-6211/6215 Devices)** PFI <0..3>
- **(USB-6212/6216 Devices)** PFI <0..15>

- **(USB-6218 Devices)** PFI <0..3>, PFI <8..11>
- AI Start Trigger (ai/StartTrigger)

The source also can be one of several internal signals on your USB-621x device. Refer to *Device Routing in MAX* in the *NI-DAQmx Help* or the *LabVIEW Help* in version 8.0 or later for more information.

You also can specify whether the waveform generation begins on the rising edge or falling edge of AO Start Trigger.

Routing AO Start Trigger to an Output Terminal

You can route AO Start Trigger out to any output PFI terminal. The output is an active high pulse.

AO Pause Trigger Signal

Use the AO Pause Trigger signal (ao/PauseTrigger) to pause the generation of AO samples in a DAQ sequence. That is, when AO Pause Trigger is active, no samples occur.

If the AO Sample Clock is derived from AO Sample Clock Timebase—for example, when you choose the onboard 20 MHz or 100 kHz Timebase—the AO Sample Clock Timebase is divided down by a programmable clock divider circuit and then drives AO Sample Clock, as shown in Figure 5-3.

In this case, AO Pause Trigger masks off AO Sample Clock Timebase pulses from the programmable clock divider.

For example, an internal timebase is routed to AO Sample Clock Timebase and the Timebase divisor is 5, as shown in Figure 5-4. AO Sample Clock normally asserts once for every five periods of AO Sample Clock Timebase; the programmable clock divider counts down from 4 to 0. When AO Pause Trigger is asserted, the programmable clock divider ignores pulses of AO Sample Clock Timebase.

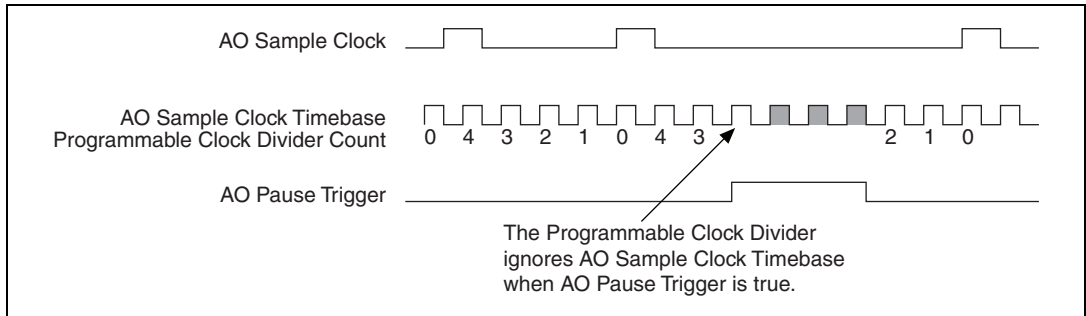

Figure 5-4. AO Pause Trigger Example

If you are using any signal as the source of your sample clock, the generation resumes as soon as AO Pause Trigger is deasserted and another edge of the sample clock is received, as shown in Figure 5-5.

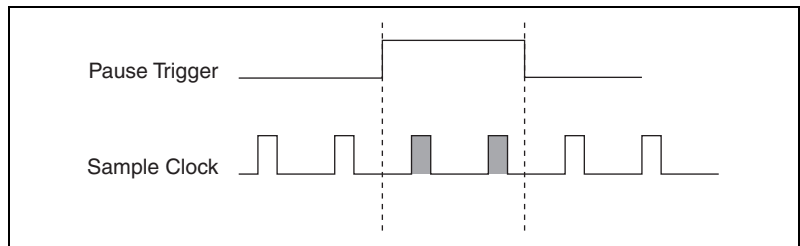

Figure 5-5. AO Pause Trigger with Other Signal Source

Using a Digital Source

To use AO Pause Trigger, specify a source and a polarity. The source can be any input PFI signal.

The source also can be one of several other internal signals on your USB-621x device. Refer to *Device Routing in MAX* in the *NI-DAQmx Help* or the *LabVIEW Help* in version 8.0 or later for more information.

You also can specify whether the samples are paused when AO Pause Trigger is at a logic high or low level.

AO Sample Clock Signal

Use the AO Sample Clock (ao/SampleClock) signal to initiate AO samples. Each sample updates the outputs of all of the DACs. You can specify an internal or external source for AO Sample Clock. You also can specify whether the DAC update begins on the rising edge or falling edge of AO Sample Clock.

Using an Internal Source

One of the following internal signals can drive AO Sample Clock:

- AO Sample Clock Timebase (divided down)
- Counter n Internal Output

A programmable internal counter divides down the AO Sample Clock Timebase signal.

Using an External Source

Use any input PFI line as the source of AO Sample Clock.

Routing AO Sample Clock to an Output Terminal

You can route AO Sample Clock (as an active low signal) out to any output PFI terminal.

Other Timing Requirements

A counter on your device internally generates AO Sample Clock unless you select an external source. AO Start Trigger starts the counter and either the software or hardware can stop it once a finite generation completes. When using an internally generated AO Sample Clock, you also can specify a configurable delay from AO Start Trigger to the first AO Sample Clock pulse. By default, this delay is two ticks of AO Sample Clock Timebase.

Figure 5-6 shows the relationship of AO Sample Clock to AO Start Trigger.

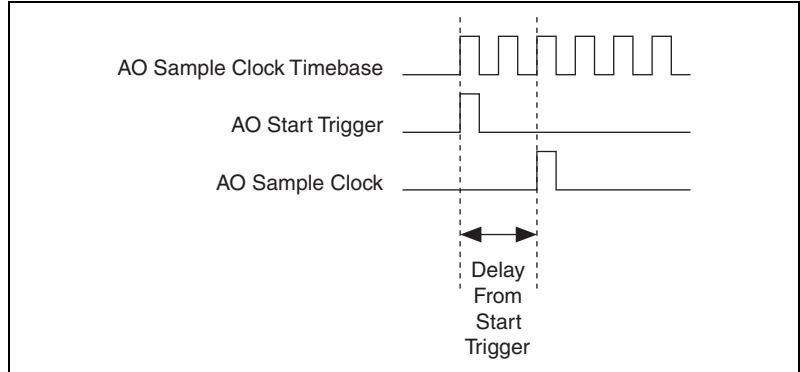

Figure 5-6. AO Sample Clock and AO Start Trigger

AO Sample Clock Timebase Signal

The AO Sample Clock Timebase (`ao/SampleClockTimebase`) signal is divided down to provide a source for AO Sample Clock.

You can route any of the following signals to be the AO Sample Clock Timebase signal:

- 20 MHz Timebase
- 100 kHz Timebase
- **(USB-6211/6215 Devices)** PFI <0..3>
- **(USB-6212/6216 Devices)** PFI <0..15>
- **(USB-6218 Devices)** PFI <0..3>, PFI <8..11>

AO Sample Clock Timebase is not available as an output on the I/O connector.

You might use AO Sample Clock Timebase if you want to use an external sample clock signal, but need to divide the signal down. If you want to use an external sample clock signal, but do not need to divide the signal, then you should use AO Sample Clock rather than AO Sample Clock Timebase.

Getting Started with AO Applications in Software

You can use a USB-621x device in the following analog output applications:

- Single-point (on-demand) generation
- Finite generation
- Continuous generation
- Waveform generation

You can perform these generations through programmed I/O or USB Signal Stream data transfer mechanisms. Some of the applications also use start triggers and pause triggers.



Note For more information about programming analog output applications and triggers in software, refer to the *NI-DAQmx Help* or the *LabVIEW Help* in version 8.0 or later.

Digital I/O

Refer to one of the following sections, depending on your device:

- *Digital I/O on USB-6210/6211/6215/6218 Devices*—USB-6210/6211/6215/6218 devices have up to eight lines of digital inputs (DI) and up to eight lines of digital output (DO).
- *Digital I/O on USB-6212/6216 Devices*—USB-6212/6216 devices have 32 bidirectional static digital I/O (DIO) lines.

Digital I/O on USB-6210/6211/6215/6218 Devices

USB-6210/6211/6215/6218 devices have up to eight static digital input lines, P0.<0..7>. These lines also can be used as PFI inputs.

USB-6210/6211/6215/6218 devices have up to eight static digital output lines, P1.<0..7>. These lines also can be used as PFI output. By default the digital output lines are disabled (high impedance with a 47 k Ω pull-down resistor) on power up. Software can enable or disable the entire port (software cannot enable individual lines). Once the port is enabled, you can individually configure each line to the following:

- Set a line to a static 0
- Set a line to a static 1
- Export a timing output signal to a line as a PFI pin

The voltage input and output levels and the current drive level of the DI and DO lines are listed in the *NI USB-621x Specifications*. Refer to Chapter 7, *PFI*, for more information on PFI inputs and outputs.

Figure 6-1 shows the circuitry of one DI line and one DO line. The following sections provide information about the various parts of the DIO circuit.

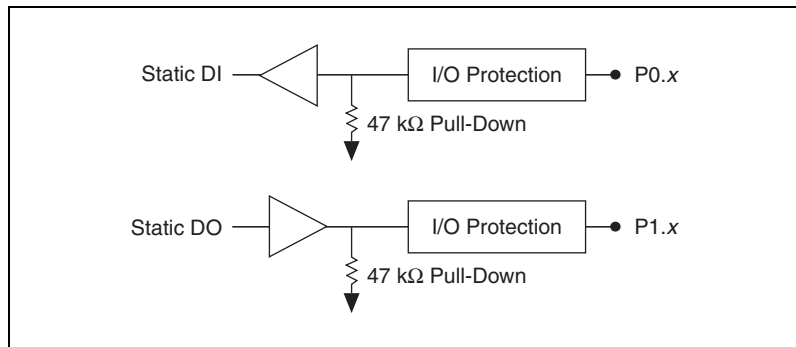

Figure 6-1. USB-6210/6211/6215/6218 Digital I/O Circuitry

The DI terminals are named P0.<0..7> on the USB-6210/6211/6215/6218 device I/O connector. The DO terminals are named P1.<0..7> on the USB-6210/6211/6215/6218 device I/O connector.

The voltage input and output levels and the current drive levels of the DIO lines are listed in the *NI USB-621x Specifications*.

Static DIO on USB-6210/6211/6215/6218 Devices

You can use static DI and DO lines to monitor or control digital signals. All samples of static DI lines and updates of DO lines are software-timed.

I/O Protection on USB-6210/6211/6215/6218 Devices

Each DI, DO, and PFI signal is protected against overvoltage, undervoltage, and overcurrent conditions as well as ESD events. However, you should avoid these fault conditions by following these guidelines:

- Do *not* connect a DO or PFI output lines to any external signal source, ground signal, or power supply.
- Understand the current requirements of the load connected to DO or PFI output signals. Do *not* exceed the specified current output limits of the DAQ device. NI has several signal conditioning solutions for digital applications requiring high current drive.
- Do *not* drive a DI or PFI input line with voltages outside of its normal operating range. The PFI or DI lines have a smaller operating range than the AI signals.

Increasing Current Drive on USB-6210/6211/6215/6218 Devices

The total internal current limit for digital outputs and power drawn from the +5 V terminals is 50 mA. You can increase this internal current limit by supplying an external +5 V supply. Refer to the [+5 V Power as an Input](#) section of Chapter 3, [Connector and LED Information](#).

Connecting Digital I/O Signals on USB-6210/6211/6215/6218 Devices

The DI and DO signals, P0.<0..7> and P1.<0..7> are referenced to D GND. Digital input applications include receiving TTL signals and sensing external device states, such as the state of the switch shown in the figure. Digital output applications include sending TTL signals and driving external devices, such as the LED shown in Figure 6-2.

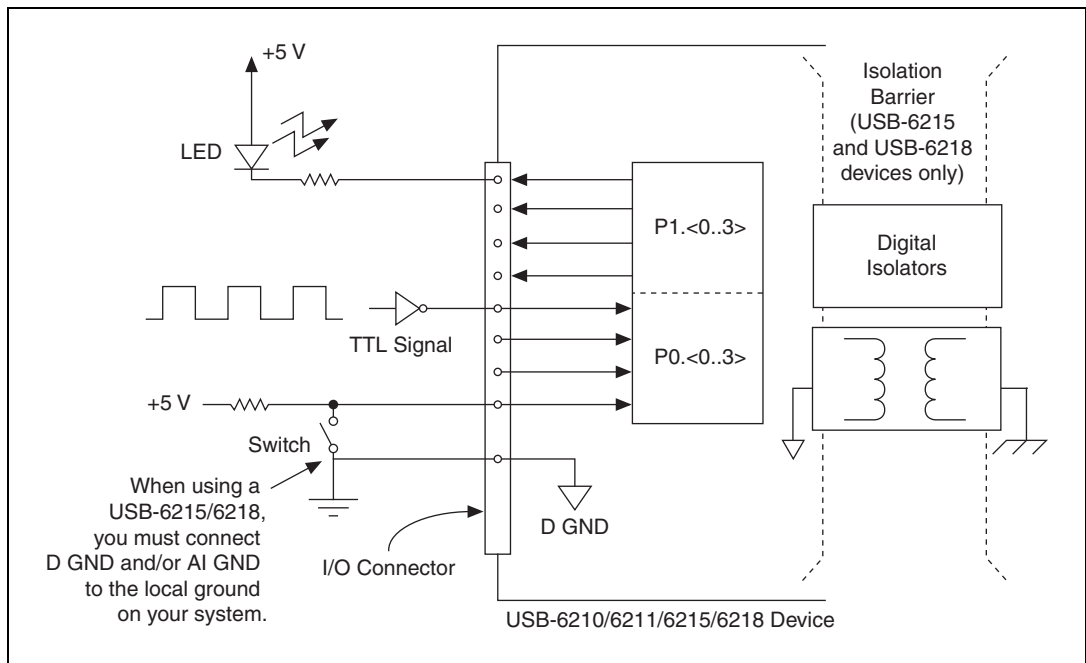

Figure 6-2. USB-6210/6211/6215/6218 Digital I/O Connections



Caution Exceeding the maximum input voltage ratings, which are listed in the *NI USB-621x Specifications*, can damage the DAQ device and the computer. NI is *not* liable for any damage resulting from such signal connections.

Getting Started with DIO Applications in Software on USB-6210/6211/6215/6218 Devices

You can use the USB-6210/6211/6215/6218 device in the following digital I/O applications:

- Static digital input
- Static digital output



Note For more information about programming digital I/O applications and triggers in software, refer to the *NI-DAQmx Help* or the *LabVIEW Help* in version 8.0 or later.

Digital I/O on USB-6212/6216 Devices

USB-6212/6216 devices contain:

- Up to 16 DIO signals (P0.<0..15>). Each signal can be individually configured as either:
 - Static digital input
 - Static digital output
- 16 PFI/DIO signals (PFI <0..7>/P1.<0..7> and PFI <8..15>/P2.<0..7>). Each signal can be individually configured as either:
 - Static digital input
 - Static digital output
 - PFI input
 - PFI output

Each pin is called PFI *x* when used as a PFI; each pin is named P1.*x* or P2.*x* when used as a digital input or output.

Figure 6-3 shows the circuitry of one DIO line. Each DIO line is similar. The voltage input and output levels and the current drive levels of the DIO lines are listed in the *NI USB-621x Specifications*.

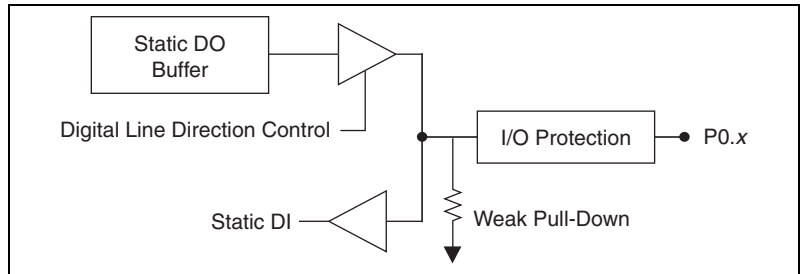

Figure 6-3. USB-6212/6216 Digital I/O Circuitry

The following sections provide information about the various parts of the DIO circuit.

Static DIO on USB-6212/6216 Devices

Each of the USB-6212/6216 DIO lines can be used as a static DI or DO line. You can use static DIO lines to monitor or control digital signals. Each DIO can be individually configured as a digital input (DI) or digital output (DO).

All samples of static DI lines and updates of DO lines are software-timed.

I/O Protection on USB-6212/6216 Devices

Each DIO and PFI signal is protected against overvoltage, undervoltage, and overcurrent conditions as well as ESD events. However, you should avoid these fault conditions by following these guidelines:

- If you configure a PFI or DIO line as an output, do *not* connect it to any external signal source, ground signal, or power supply.
- If you configure a PFI or DIO line as an output, understand the current requirements of the load connected to these signals. Do *not* exceed the specified current output limits of the DAQ device. NI has several signal conditioning solutions for digital applications requiring high current drive.
- If you configure a PFI or DIO line as an input, do *not* drive the line with voltages outside of its normal operating range. The PFI or DIO lines have a smaller operating range than the AI signals.
- Treat the DAQ device as you would treat any static sensitive device. *Always* properly ground yourself and the equipment when handling the DAQ device or connecting to it.

Programmable Power-Up States on USB-6212/6216 Devices

At system startup and reset, the hardware sets all PFI and DIO lines to high-impedance inputs by default. The DAQ device does not drive the signal high or low. Each line has a weak pull-down resistor connected to it, as described in the *NI USB-621x Specifications*.

NI-DAQmx supports programmable power-up states for PFI and DIO lines. Software can program any value at startup to the P0, P1, or P2 lines. The PFI and DIO lines can be set as:

- A high-impedance input with a weak pull-down resistor (default)
- An output driving a 0
- An output driving a 1

Refer to the *NI-DAQmx Help* or the *LabVIEW Help* in version 8.0 or later for more information about setting power-up states in NI-DAQmx or MAX.

Increasing Current Drive on USB-6212/6216 Devices

The total internal current limit for digital outputs and power drawn from the +5 V terminals is 50 mA. You can increase this internal current limit by supplying an external +5 V supply. Refer to the *+5 V Power as an Input* section of Chapter 3, *Connector and LED Information*.

Connecting Digital I/O Signals on USB-6212/6216 Devices

The DIO signals, P0.<0..15>, P1.<0..7>, and P2.<0..7> are referenced to D GND. You can individually program each line as an input or output. Figure 6-4 shows P0.<0..3> configured for digital input and P1.<0..3> configured for digital output. Digital input applications include receiving TTL signals and sensing external device states, such as the state of the switch shown in the figure. Digital output applications include sending TTL signals and driving external devices, such as the LED shown in the figure.

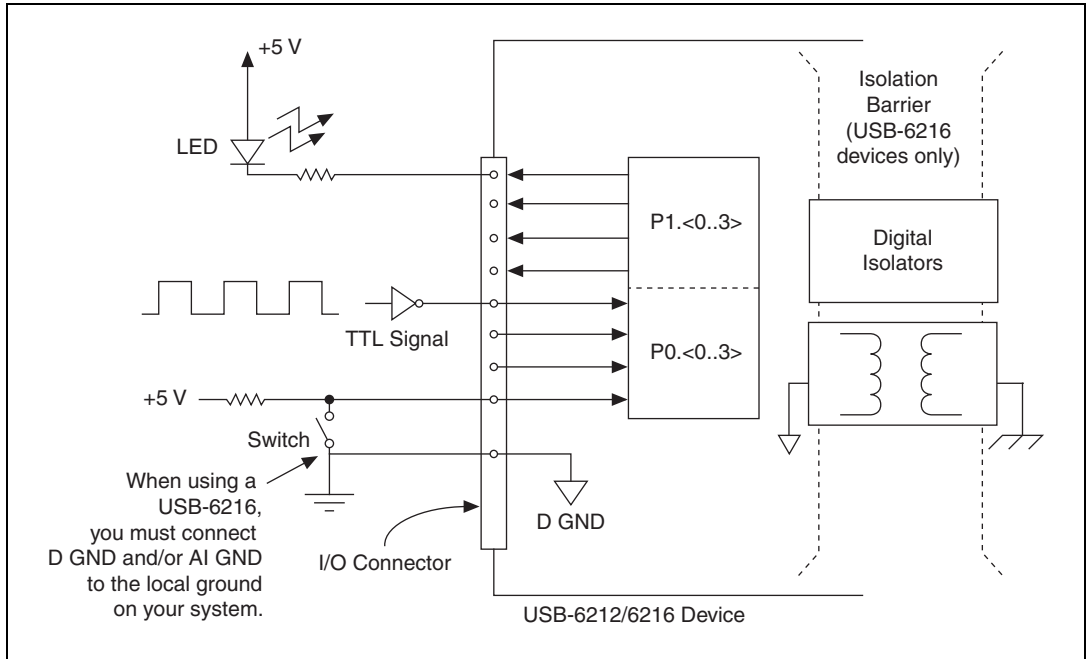

Figure 6-4. USB-6212/6216 Digital I/O Connections



Caution Exceeding the maximum input voltage ratings, which are listed in the *NI USB-621x Specifications*, can damage the DAQ device and the computer. NI is *not* liable for any damage resulting from such signal connections.

Getting Started with DIO Applications in Software on USB-6212/6216 Devices

You can use the USB-6212/6216 device in the following digital I/O applications:

- Static digital input
- Static digital output



Note For more information about programming digital I/O applications and triggers in software, refer to the *NI-DAQmx Help* or the *LabVIEW Help* in version 8.0 or later.

PFI

USB-621x devices have multiple Programmable Function Interface (PFI) signals.

Each input PFI can be individually configured as the following:

- A static digital input
- A timing input signal for AI, AO, or counter/timer functions

Each output PFI can be individually configured as the following:

- A static digital output
- A timing output signal from AI, AO, or counter/timer functions



Note (USB-6212/6216 Devices) PFI signals on USB-6212/6216 devices can be configured as input or output.

Each PFI input also has a programmable debouncing filter. Figure 7-1 shows the circuitry of an input PFI line.

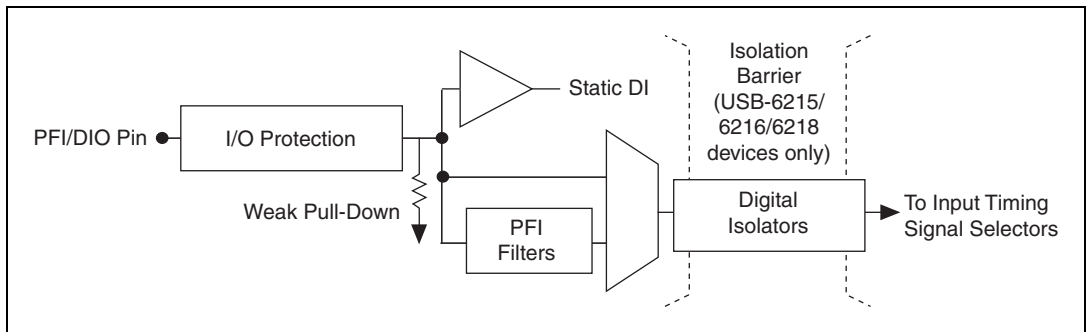

Figure 7-1. USB-621x PFI Input Circuitry

Figure 7-2 shows the circuitry of an output PFI line.

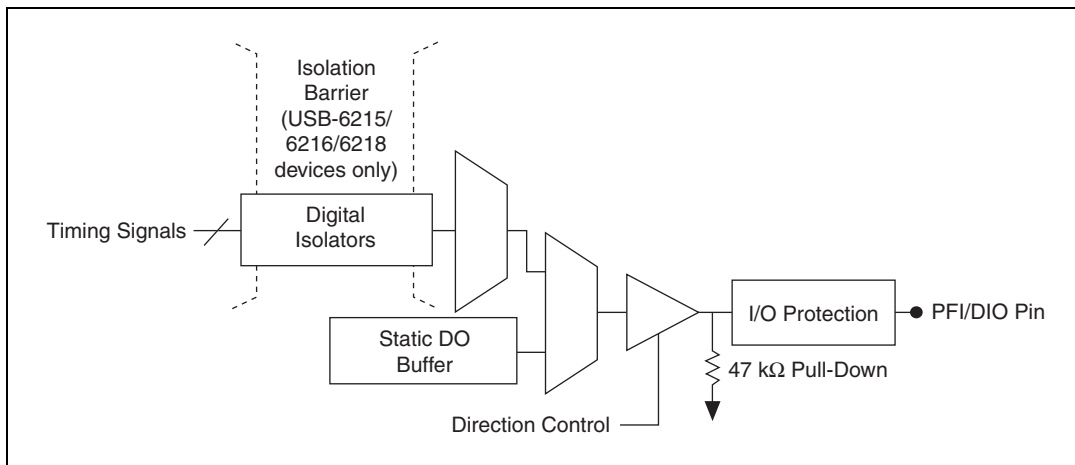

Figure 7-2. USB-621x PFI Output Circuitry

When a terminal is used as a timing input or output signal, it is called PFI *x*. When a terminal is used as a static digital input or output, it is called P0.*x*, P1.*x*, or P2.*x*.

The voltage input and output levels and the current drive levels of the PFI signals are listed in the *NI USB-621x Specifications*.

Using PFI Terminals as Timing Input Signals

Use PFI terminals to route external timing signals to many different USB-621x functions. Each input PFI terminal can be routed to any of the following signals:

- AI Convert Clock (ai/ConvertClock)
- AI Sample Clock (ai/SampleClock)
- AI Start Trigger (ai/StartTrigger)
- AI Reference Trigger (ai/ReferenceTrigger)
- AI Pause Trigger (ai/PauseTrigger)
- AI Sample Clock Timebase (ai/SampleClockTimebase)
- AO Start Trigger (ao/StartTrigger)
- AO Sample Clock (ao/SampleClock)

- AO Sample Clock Timebase (ao/SampleClockTimebase)
- AO Pause Trigger (ao/PauseTrigger)
- Counter input signals for either counter—Source, Gate, Aux, HW_Arm, A, B, Z

Most functions allow you to configure the polarity of PFI inputs and whether the input is edge or level sensitive.

Exporting Timing Output Signals Using PFI Terminals

You can route any of the following timing signals to any PFI output terminal:

- AI Convert Clock* (ai/ConvertClock)
- AI Hold Complete Event (ai/HoldCompleteEvent)
- AI Reference Trigger (ai/ReferenceTrigger)
- AI Sample Clock (ai/SampleClock)
- AI Start Trigger (ai/StartTrigger)
- AO Sample Clock* (ao/SampleClock)
- AO Start Trigger (ao/StartTrigger)
- Counter *n* Source
- Counter *n* Gate
- Counter *n* Internal Output
- Frequency Output



Note Signals with a * are inverted before being driven to a terminal; that is, these signals are active low.

Using PFI Terminals as Static Digital I/Os

Each input PFI line can be individually configured as a static digital input, called P0.x. Each output PFI line can be individually configured as a static digital output, called P1.x.¹

¹ On USB-6212/6216 devices, all PFI lines can be individually configured as static digital inputs or static digital outputs, called P0.x.

Connecting PFI Input Signals

All PFI input connections are referenced to D GND. Figure 7-3 shows this reference, and how to connect an external PFI 0 source and an external PFI 2 source to two PFI terminals.

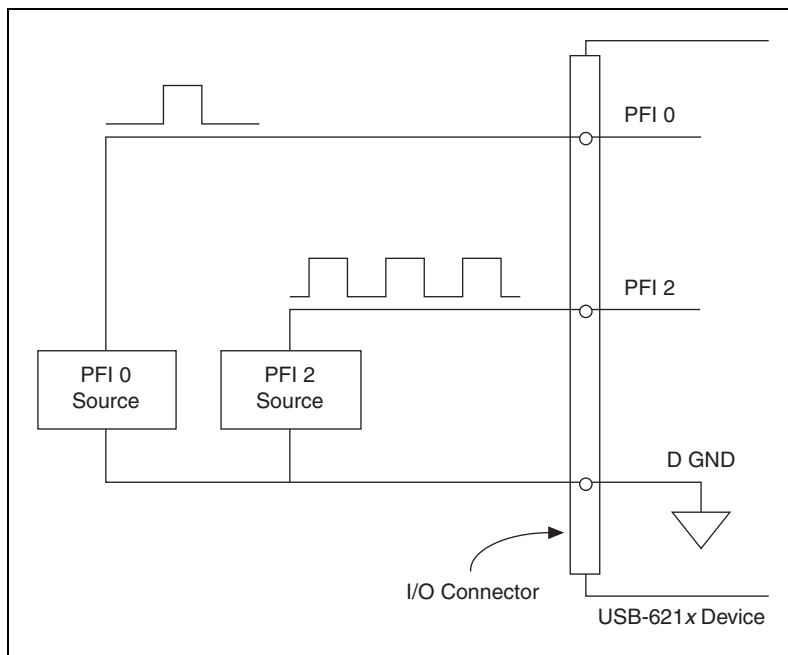

Figure 7-3. PFI Input Signals Connections

PFI Filters

You can enable a programmable debouncing filter on each PFI signal. When the filters are enabled, your device samples the input on each rising edge of a filter clock. USB-621x devices use an onboard oscillator to generate the filter clock with a 40 MHz frequency.



Note NI-DAQmx *only* supports filters on counter inputs.

The following is an example of low to high transitions of the input signal. High to low transitions work similarly.

Assume that an input terminal has been low for a long time. The input terminal then changes from low to high, but glitches several times. When the filter clock has sampled the signal high on N consecutive edges, the low to high transition is propagated to the rest of the circuit. The value of N depends on the filter setting; refer to Table 7-1.

Table 7-1. Filters

Filter Setting	N (Filter Clocks Needed to Pass Signal)	Pulse Width Guaranteed to Pass Filter	Pulse Width Guaranteed to Not Pass Filter
125 ns	5	125 ns	100 ns
6.425 μ s	257	6.425 μ s	6.400 μ s
2.56 ms	~101,800	2.56 ms	2.54 ms
Disabled	—	—	—

The filter setting for each input can be configured independently. On power up, the filters are disabled. Figure 7-4 shows an example of a low to high transition on an input that has its filter set to 125 ns ($N = 5$).

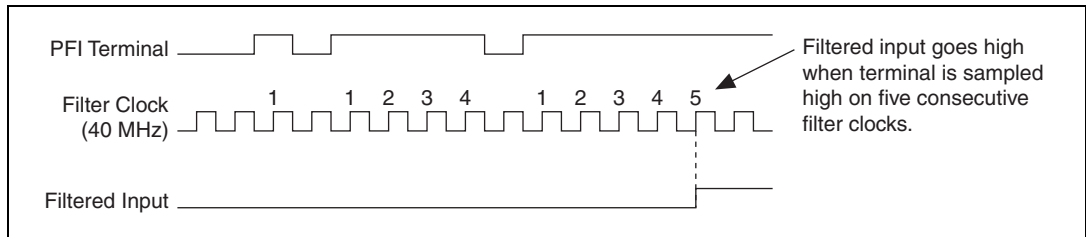

Figure 7-4. Filter Example

Enabling filters introduces jitter on the input signal. For the 125 ns and 6.425 μ s filter settings, the jitter is up to 25 ns. On the 2.56 ms setting, the jitter is up to 10.025 μ s.

Refer to the KnowledgeBase document, *Digital Filtering with M Series*, for more information about digital filters and counters. To access this KnowledgeBase, go to ni.com/info and enter the info code `rddfms`.

I/O Protection

Each DI, DO, and PFI signal is protected against overvoltage, undervoltage, and overcurrent conditions as well as ESD events. However, you should avoid these fault conditions by following these guidelines:

- Do *not* connect a DO or PFI output lines to any external signal source, ground signal, or power supply.
- Understand the current requirements of the load connected to DO or PFI output signals. Do *not* exceed the specified current output limits of the DAQ device. NI has several signal conditioning solutions for digital applications requiring high current drive.
- Do *not* drive a DI or PFI input line with voltages outside of its normal operating range. The PFI or DI lines have a smaller operating range than the AI signals.
- Treat the DAQ device as you would treat any static sensitive device. *Always* properly ground yourself and the equipment when handling the DAQ device or connecting to it.

Programmable Power-Up States

At system startup and reset, the hardware sets all output PFI and DO lines to high-impedance by default. The DAQ device does not drive the signal high or low. Each line has a weak pull-down resistor connected to it, as described in the *NI USB-621x Specifications*.

NI-DAQmx supports programmable power-up states for PFI and DIO lines. Software can program any value at startup to the P1 lines. The output PFI and DO lines can be set as:

- A high-impedance input with a weak pull-down resistor (default)
- An output driving a 0
- An output driving a 1

Refer to the *NI-DAQmx Help* or the *LabVIEW Help* in version 8.0 or later for more information about setting power-up states in NI-DAQmx or MAX.

Counters

USB-621x devices have two general-purpose 32-bit counter/timers and one frequency generator, as shown in Figure 8-1. The general-purpose counter/timers can be used for many measurement and pulse generation applications.

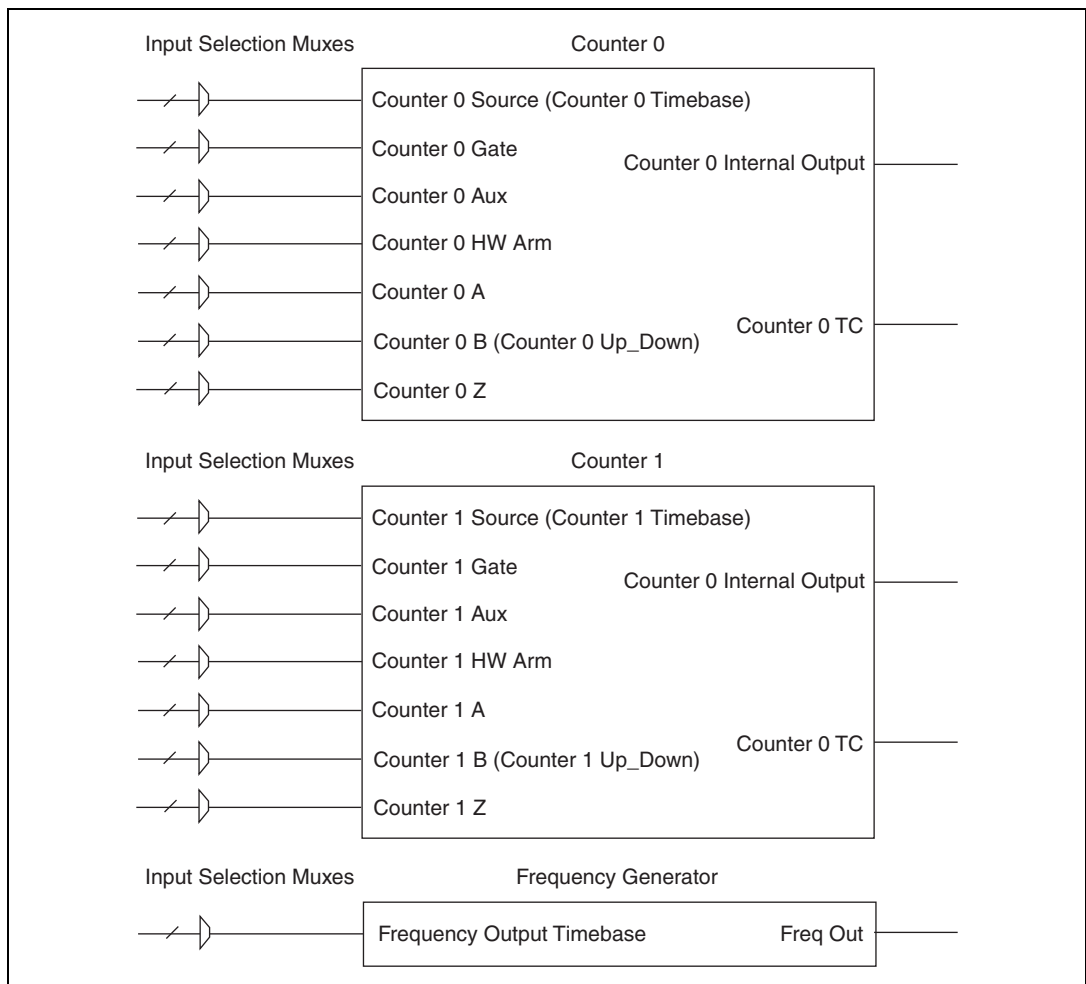

Figure 8-1. USB-621x Counters

The counters have seven input signals, although in most applications only a few inputs are used.

For information about connecting counter signals, refer to the [Default Counter/Timer Pinouts](#) section.

Counter Input Applications

Counting Edges

In edge counting applications, the counter counts edges on its Source after the counter is armed. You can configure the counter to count rising or falling edges on its Source input. You also can control the direction of counting (up or down).

The counter values can be read on demand or with a sample clock.

Single Point (On-Demand) Edge Counting

With single point (on-demand) edge counting, the counter counts the number of edges on the Source input after the counter is armed. On-demand refers to how the software can read the counter contents at any time without disturbing the counting process. Figure 8-2 shows an example of single point edge counting.

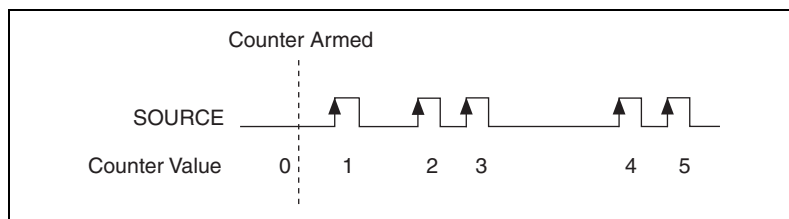

Figure 8-2. Single Point Edge Counting

You also can use a pause trigger to pause (or gate) the counter. When the pause trigger is active, the counter ignores edges on its Source input. When the pause trigger is inactive, the counter counts edges normally.

You can route the pause trigger to the Gate input of the counter. You can configure the counter to pause counting when the pause trigger is high or when it is low. Figure 8-3 shows an example of on-demand edge counting with a pause trigger.

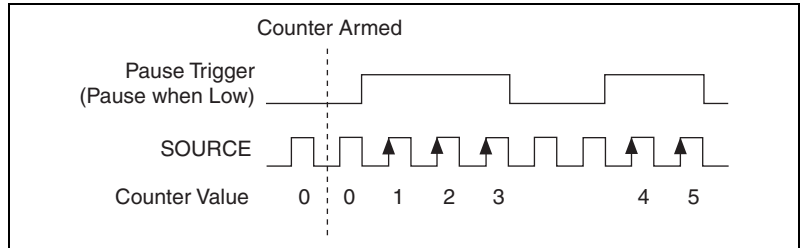

Figure 8-3. Single Point Edge Counting with Pause Trigger

Buffered (Sample Clock) Edge Counting

With buffered edge counting (edge counting using a sample clock), the counter counts the number of edges on the Source input after the counter is armed. The value of the counter is sampled on each active edge of a sample clock. A USB Signal Stream transfers the sampled values to host memory.

The count values returned are the cumulative counts since the counter armed event; that is, the sample clock does not reset the counter.

You can route the counter sample clock to the Gate input of the counter. You can configure the counter to sample on the rising or falling edge of the sample clock.

Figure 8-4 shows an example of buffered edge counting. Notice that counting begins when the counter is armed, which occurs before the first active edge on Gate.

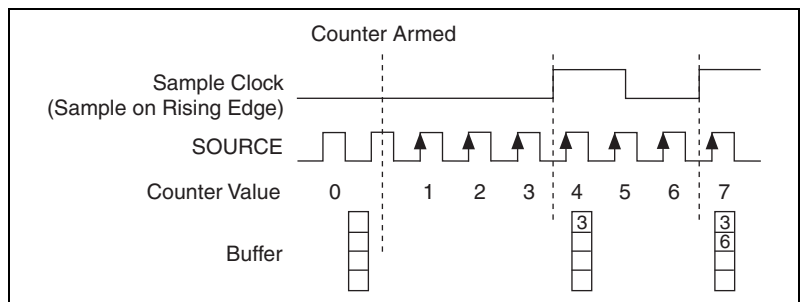

Figure 8-4. Buffered (Sample Clock) Edge Counting

Controlling the Direction of Counting

In edge counting applications, the counter can count up or down. You can configure the counter to do the following:

- Always count up
- Always count down
- Count up when the Counter n B input is high; count down when it is low

For information about connecting counter signals, refer to the [Default Counter/Timer Pinouts](#) section.

Pulse-Width Measurement

In pulse-width measurements, the counter measures the width of a pulse on its Gate input signal. You can configure the counter to measure the width of high pulses or low pulses on the Gate signal.

You can route an internal or external periodic clock signal (with a known period) to the Source input of the counter. The counter counts the number of rising (or falling) edges on the Source signal while the pulse on the Gate signal is active.

You can calculate the pulse width by multiplying the period of the Source signal by the number of edges returned by the counter.

A pulse-width measurement is accurate even if the counter is armed while a pulse train is in progress. If a counter is armed while the pulse is in the active state, it waits for the next transition to the active state to begin the measurement.

Single Pulse-Width Measurement

With single pulse-width measurement, the counter counts the number of edges on the Source input while the Gate input remains active. When the Gate input goes inactive, the counter stores the count in a hardware save register and ignores other edges on the Gate and Source inputs. Software then reads the stored count.

Figure 8-5 shows an example of a single pulse-width measurement.

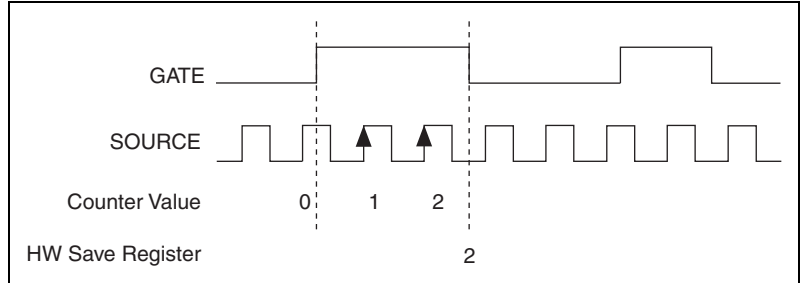

Figure 8-5. Single Pulse-Width Measurement

Buffered Pulse-Width Measurement

Buffered pulse-width measurement is similar to single pulse-width measurement, but buffered pulse-width measurement takes measurements over multiple pulses.

The counter counts the number of edges on the Source input while the Gate input remains active. On each trailing edge of the Gate signal, the counter stores the count in a hardware save register. A USB Signal Stream transfers the stored values to host memory.

Figure 8-6 shows an example of a buffered pulse-width measurement.

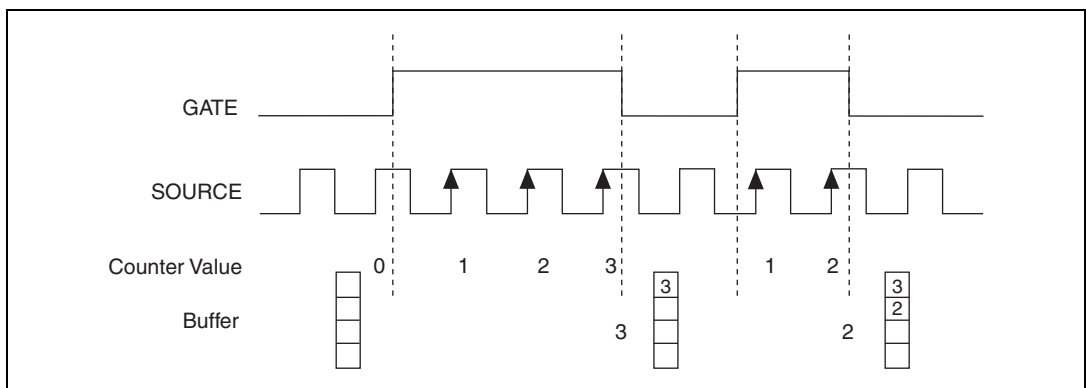

Figure 8-6. Buffered Pulse-Width Measurement

Note that if you are using an external signal as the Source, at least one Source pulse should occur between each active edge of the Gate signal. This condition ensures that correct values are returned by the counter. If this

condition is not met, consider using duplicate count prevention, described in the [Duplicate Count Prevention](#) section.

For information about connecting counter signals, refer to the [Default Counter/Timer Pinouts](#) section.

Period Measurement

In period measurements, the counter measures a period on its Gate input signal after the counter is armed. You can configure the counter to measure the period between two rising edges or two falling edges of the Gate input signal.

You can route an internal or external periodic clock signal (with a known period) to the Source input of the counter. The counter counts the number of rising (or falling) edges occurring on the Source input between the two active edges of the Gate signal.

You can calculate the period of the Gate input by multiplying the period of the Source signal by the number of edges returned by the counter.

Single Period Measurement

With single period measurement, the counter counts the number of rising (or falling) edges on the Source input occurring between two active edges of the Gate input. On the second active edge of the Gate input, the counter stores the count in a hardware save register and ignores other edges on the Gate and Source inputs. Software then reads the stored count.

Figure 8-7 shows an example of a single period measurement.

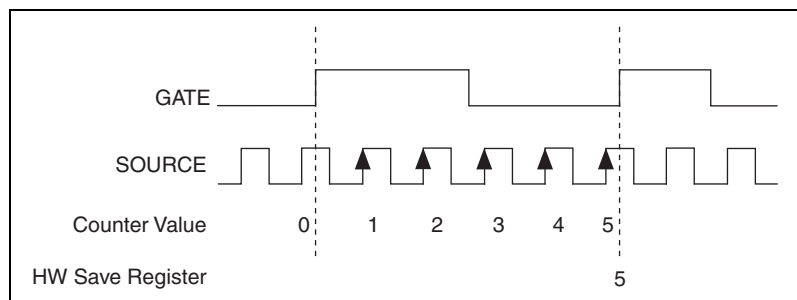

Figure 8-7. Single Period Measurement

Buffered Period Measurement

Buffered period measurement is similar to single period measurement, but buffered period measurement measures multiple periods.

The counter counts the number of rising (or falling) edges on the Source input between each pair of active edges on the Gate input. At the end of each period on the Gate signal, the counter stores the count in a hardware save register. A USB Signal Stream transfers the stored values to host memory.

The counter begins on the first active edge of the Gate after it is armed. The arm usually occurs in the middle of a period of the Gate input. The counter does not store a measurement for this incomplete period.

Figure 8-8 shows an example of a buffered period measurement. In this example, a period is defined by two consecutive rising edges.

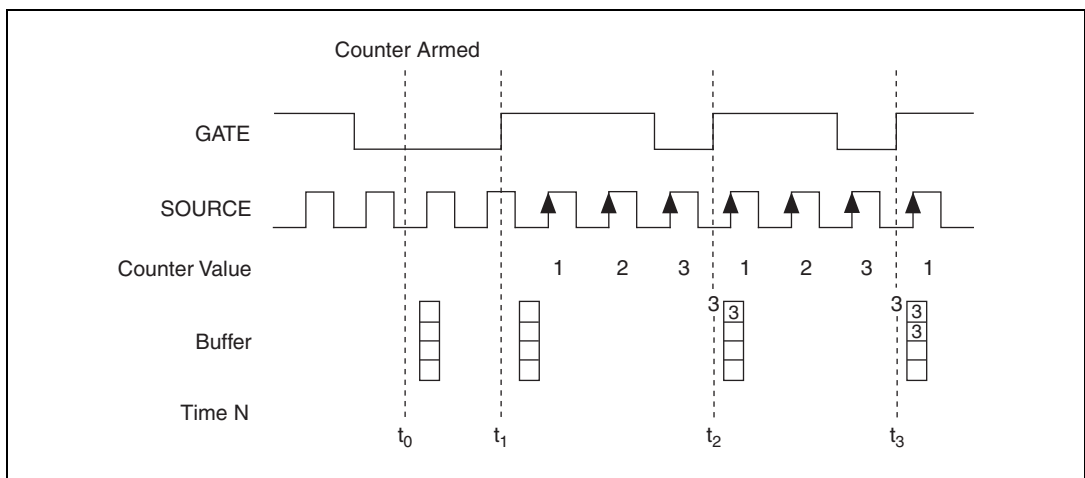

- t_0 At t_0 , the counter is armed. No measurements are taken until the counter is armed.
- t_1 The rising edge of Gate indicates the beginning of the first period to measure. The counter begins counting rising edges of Source.
- t_2 The rising edge of Gate indicates the end of the first period. The USB-621x device stores the counter value in the buffer.
- t_3 The rising edge of Gate indicates the end of the second period. The USB-621x device stores the counter value in the buffer.

Figure 8-8. Buffered Period Measurement

Note that if you are using an external signal as the Source, at least one Source pulse should occur between each active edge of the Gate signal. This condition ensures that correct values are returned by the counter. If this condition is not met, the counter returns a zero. Refer to the [Duplicate Count Prevention](#) section for more information.

For information about connecting counter signals, refer to the [Default Counter/Timer Pinouts](#) section.

Semi-Period Measurement

In semi-period measurements, the counter measures a semi-period on its Gate input signal after the counter is armed. A semi-period is the time between any two consecutive edges on the Gate input.

You can route an internal or external periodic clock signal (with a known period) to the Source input of the counter. The counter counts the number of rising (or falling) edges occurring on the Source input between two edges of the Gate signal.

You can calculate the semi-period of the Gate input by multiplying the period of the Source signal by the number of edges returned by the counter.

Single Semi-Period Measurement

Single semi-period measurement is equivalent to single pulse-width measurement.

Buffered Semi-Period Measurement

In buffered semi-period measurement, on each edge of the Gate signal, the counter stores the count in a hardware save register. A USB Signal Stream transfers the stored values to host memory.

The counter begins counting on the first active edge of the Gate after it is armed. The arm usually occurs between edges on the Gate input. The counter does not store a value for this incomplete semi-period.

Figure 8-9 shows an example of a buffered semi-period measurement.

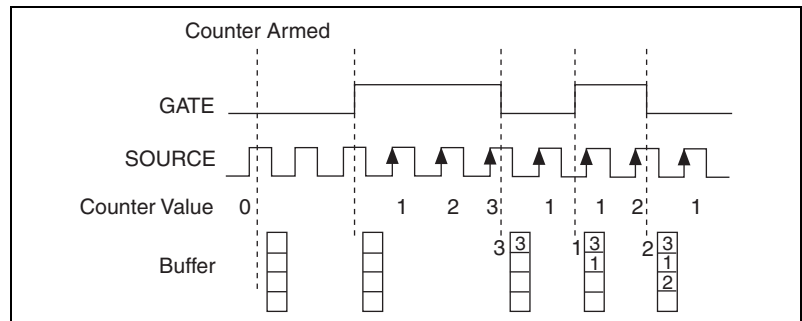

Figure 8-9. Buffered Semi-Period Measurement

Note that if you are using an external signal as the Source, at least one Source pulse should occur between each active edge of the Gate signal. This condition ensures that correct values are returned by the counter. If this condition is not met, the counter returns a zero. Refer to the [Duplicate Count Prevention](#) section for more information.

For information about connecting counter signals, refer to the [Default Counter/Timer Pinouts](#) section.

Frequency Measurement

You can use the counters to measure frequency in several different ways. You can choose one of the following methods depending on your application:

- Method 1: Measure Low Frequency with One Counter**—In this method, you measure one period of your signal using a known timebase. This method is good for low frequency signals.

You can route the signal to measure (F1) to the Gate of a counter. You can route a known timebase (Ft) to the Source of the counter. The known timebase can be 80MHzTimebase. For signals that might be slower than 0.02 Hz, use a slower known timebase.

You can configure the counter to measure one period of the gate signal. The frequency of F1 is the inverse of the period. Figure 8-10 illustrates method 1.

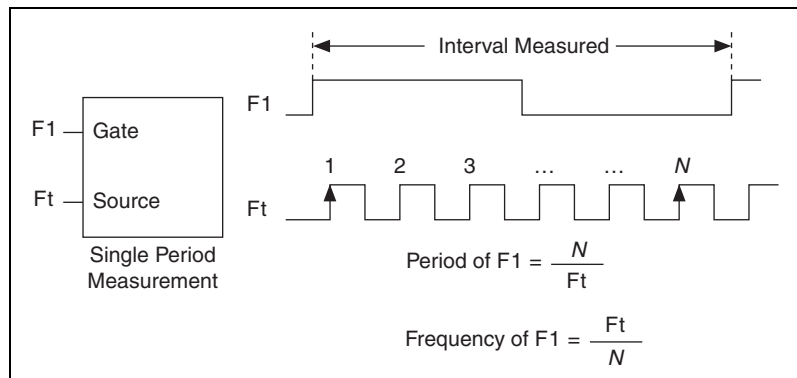

Figure 8-10. Method 1

- Method 1b: Measure Low Frequency with One Counter (Averaged)**—In this method, you measure several periods of your signal using a known timebase. This method is good for low to medium frequency signals.

You can route the signal to measure (F1) to the Gate of a counter. You can route a known timebase (Ft) to the Source of the counter. The known timebase can be 80MHzTimebase. For signals that might be slower than 0.02 Hz, use a slower known timebase.

You can configure the counter to make K + 1 buffered period measurements. Recall that the first period measurement in the buffer should be discarded.

Average the remaining K period measurements to determine the average period of F1. The frequency of F1 is the inverse of the average period. Figure 8-11 illustrates this method.

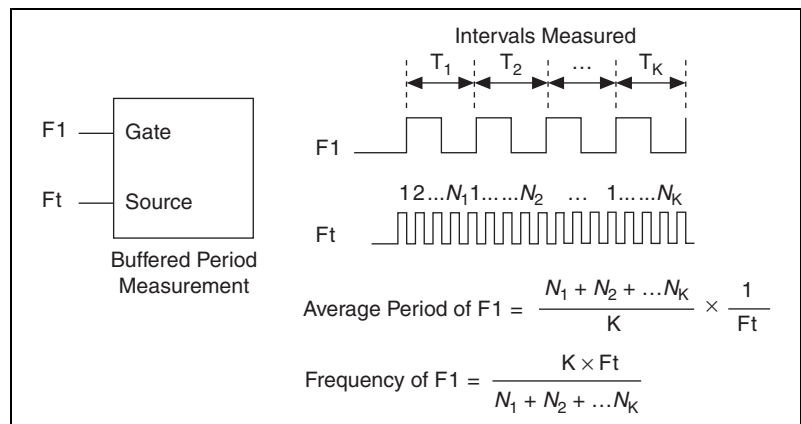

Figure 8-11. Method 1b

- Method 2: Measure High Frequency with Two Counters**—In this method, you measure one pulse of a known width using your signal and derive the frequency of your signal from the result. This method is good for high frequency signals.

In this method, you route a pulse of known duration (T) to the Gate of a counter. You can generate the pulse using a second counter. You also can generate the pulse externally and connect it to a PFI terminal. You only need to use one counter if you generate the pulse externally.

Route the signal to measure ($F1$) to the Source of the counter. Configure the counter for a single pulse-width measurement. Suppose you measure the width of pulse T to be N periods of $F1$. Then the frequency of $F1$ is N/T .

Figure 8-12 illustrates this method. Another option would be to measure the width of a known period instead of a known pulse.

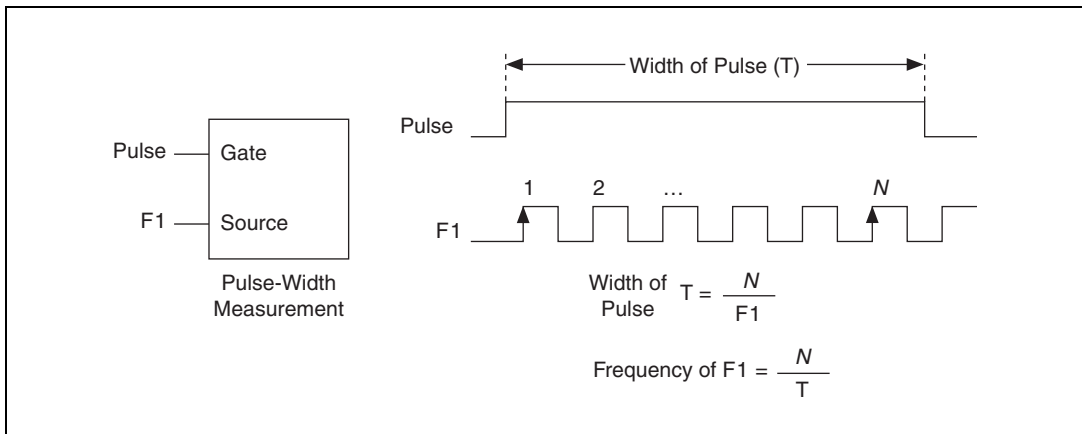

Figure 8-12. Method 2

- Method 3: Measure Large Range of Frequencies Using Two Counters**—By using two counters, you can accurately measure a signal that might be high or low frequency. This technique is called reciprocal frequency measurement. In this method, you generate a long pulse using the signal to measure. You then measure the long pulse with a known timebase. The USB-621x device can measure this long pulse more accurately than the faster input signal.

You can route the signal to measure to the Source input of Counter 0, as shown in Figure 8-13. Assume this signal to measure has frequency $F1$. Configure Counter 0 to generate a single pulse that is the width of N periods of the source input signal.

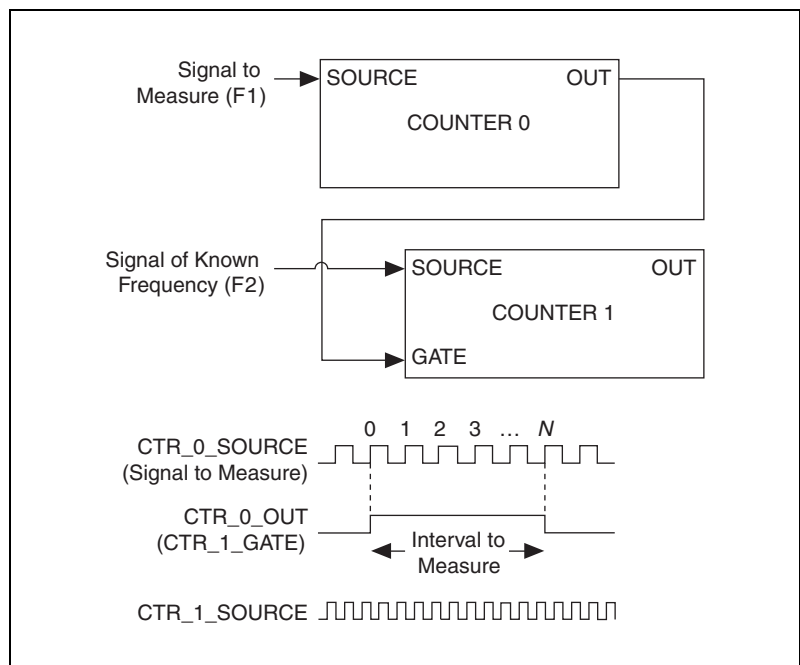

Figure 8-13. Method 3

Then route the Counter 0 Internal Output signal to the Gate input of Counter 1. You can route a signal of known frequency ($F2$) to the Counter 1 Source input. $F2$ can be 80MHzTimebase . For signals that might be slower than 0.02 Hz , use a slower known timebase. Configure Counter 1 to perform a single pulse-width measurement. Suppose the result is that the pulse width is J periods of the $F2$ clock.

From Counter 0, the length of the pulse is $N/F1$. From Counter 1, the length of the same pulse is $J/F2$. Therefore, the frequency of F1 is given by $F1 = F2 * (N/J)$.

Choosing a Method for Measuring Frequency

The best method to measure frequency depends on several factors including the expected frequency of the signal to measure, the desired accuracy, how many counters are available, and the measurement duration.

- Method 1 uses only one counter. It is a good method for many applications. However, the accuracy of the measurement decreases as the frequency increases.

Consider a frequency measurement on a 50 kHz signal using an 80 MHz Timebase. This frequency corresponds to 1,600 cycles of the 80 MHz Timebase. Your measurement may return $1,600 \pm 1$ cycles depending on the phase of the signal with respect to the timebase. As your frequency becomes larger, this error of ± 1 cycle becomes more significant; Table 8-1 illustrates this point.

Table 8-1. Frequency Measurement Method 1

Task	Equation	Example 1	Example 2
Actual Frequency to Measure	F1	50 kHz	5 MHz
Timebase Frequency	Ft	80 MHz	80 MHz
Actual Number of Timebase Periods	Ft/F1	1,600	16
Worst Case Measured Number of Timebase Periods	$(Ft/F1) - 1$	1,599	15
Measured Frequency	$Ft F1 / (Ft - F1)$	50.031 kHz	5.33 MHz
Error	$[Ft F1 / (Ft - F1)] - F1$	31 Hz	333 kHz
Error %	$[Ft / (Ft - F1)] - 1$	0.06%	6.67%

- Method 1b (measuring K periods of F1) improves the accuracy of the measurement. A disadvantage of Method 1b is that you have to take $K + 1$ measurements. These measurements take more time and consume some of the available USB bandwidth.

- Method 2 is accurate for high frequency signals. However, the accuracy decreases as the frequency of the signal to measure decreases. At very low frequencies, Method 2 may be too inaccurate for your application. Another disadvantage of Method 2 is that it requires two counters (if you cannot provide an external signal of known width). An advantage of Method 2 is that the measurement completes in a known amount of time.
- Method 3 measures high and low frequency signals accurately. However, it requires two counters.

Table 8-2 summarizes some of the differences in methods of measuring frequency.

Table 8-2. Frequency Measurement Method Comparison

Method	Number of Counters Used	Number of Measurements Returned	Measures High Frequency Signals Accurately	Measures Low Frequency Signals Accurately
1	1	1	Poor	Good
1b	1	Many	Fair	Good
2	1 or 2	1	Good	Poor
3	2	1	Good	Good

For information about connecting counter signals, refer to the [Default Counter/Timer Pinouts](#) section.

Position Measurement

You can use the counters to perform position measurements with quadrature encoders or two-pulse encoders. You can measure angular position with X1, X2, and X4 angular encoders. Linear position can be measured with two-pulse encoders. You can choose either a single point (on-demand) position measurement or a buffered (sample clock) position measurement. You must arm a counter to begin position measurements.

Measurements Using Quadrature Encoders

The counters can perform measurements of quadrature encoders that use X1, X2, or X4 encoding. A quadrature encoder can have up to three channels—channels A, B, and Z.

- X1 Encoding**—When channel A leads channel B in a quadrature cycle, the counter increments. When channel B leads channel A in a quadrature cycle, the counter decrements. The amount of increments and decrements per cycle depends on the type of encoding—X1, X2, or X4.

Figure 8-14 shows a quadrature cycle and the resulting increments and decrements for X1 encoding. When channel A leads channel B, the increment occurs on the rising edge of channel A. When channel B leads channel A, the decrement occurs on the falling edge of channel A.

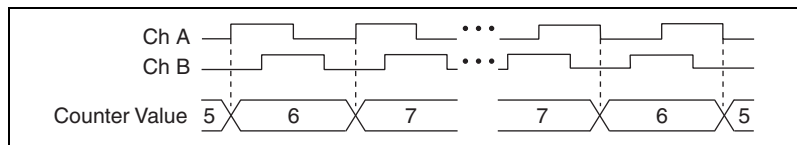

Figure 8-14. X1 Encoding

- X2 Encoding**—The same behavior for X1 encoding holds for X2 encoding except the counter increments or decrements on each edge of channel A, depending on which channel leads the other. Each cycle results in two increments or decrements, as shown in Figure 8-15.

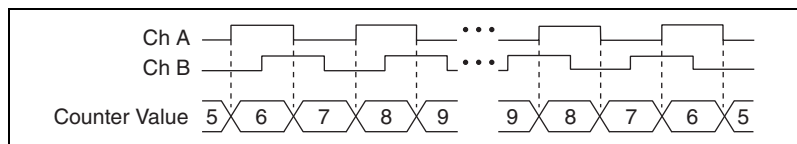

Figure 8-15. X2 Encoding

- X4 Encoding**—Similarly, the counter increments or decrements on each edge of channels A and B for X4 encoding. Whether the counter increments or decrements depends on which channel leads the other. Each cycle results in four increments or decrements, as shown in Figure 8-16.

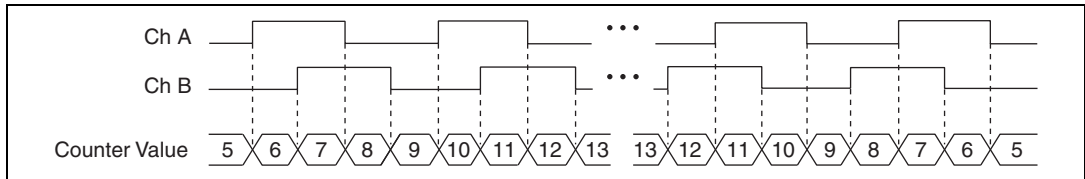

Figure 8-16. X4 Encoding

Channel Z Behavior

Some quadrature encoders have a third channel, channel Z, which is also referred to as the index channel. A high level on channel Z causes the counter to be reloaded with a specified value in a specified phase of the quadrature cycle. You can program this reload to occur in any one of the four phases in a quadrature cycle.

Channel Z behavior—when it goes high and how long it stays high—differs with quadrature encoder designs. You must refer to the documentation for your quadrature encoder to obtain timing of channel Z with respect to channels A and B. You must then ensure that channel Z is high during at least a portion of the phase you specify for reload. For instance, in Figure 8-17, channel Z is never high when channel A is high and channel B is low. Thus, the reload must occur in some other phase.

In Figure 8-17, the reload phase is when both channel A and channel B are low. The reload occurs when this phase is true and channel Z is high. Incrementing and decrementing takes priority over reloading. Thus, when the channel B goes low to enter the reload phase, the increment occurs first. The reload occurs within one maximum timebase period after the reload phase becomes true. After the reload occurs, the counter continues to count as before. The figure illustrates channel Z reload with X4 decoding.

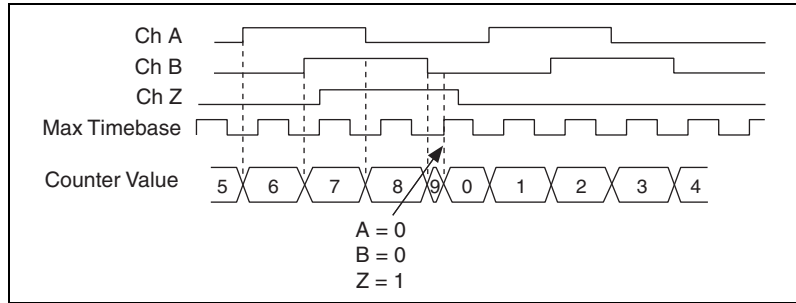

Figure 8-17. Channel Z Reload with X4 Decoding

Measurements Using Two Pulse Encoders

The counter supports two pulse encoders that have two channels—channels A and B.

The counter increments on each rising edge of channel A. The counter decrements on each rising edge of channel B, as shown in Figure 8-18.

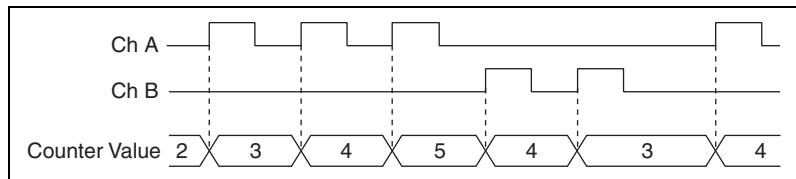

Figure 8-18. Measurements Using Two Pulse Encoders

For information about connecting counter signals, refer to the [Default Counter/Timer Pinouts](#) section.

Buffered (Sample Clock) Position Measurement

With buffered position measurement (position measurement using a sample clock), the counter increments based on the encoding used after the counter is armed. The value of the counter is sampled on each active edge of a sample clock. A DMA controller transfers the sampled values to host memory. The count values returned are the cumulative counts since the counter armed event; that is, the sample clock does not reset the counter. You can route the counter sample clock to the Gate input of the counter. You can configure the counter to sample on the rising or falling edge of the sample clock.

Figure 8-19 shows an example of a buffered X1 position measurement.

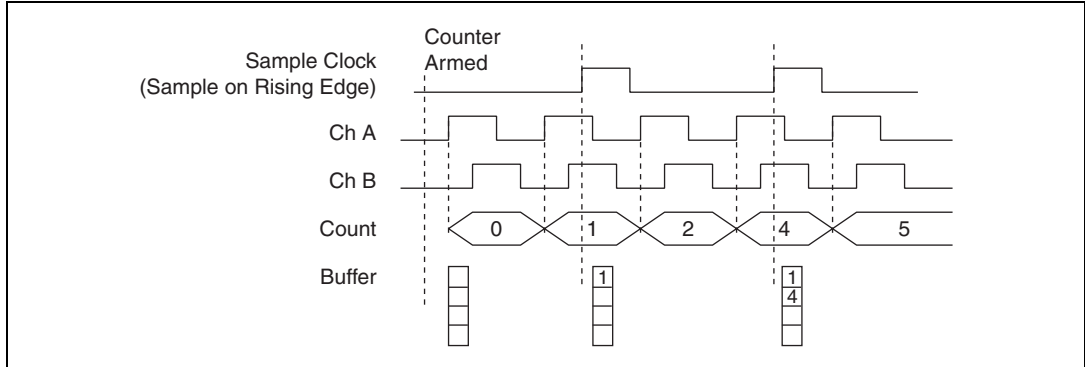

Figure 8-19. Buffered Position Measurement

Two-Signal Edge-Separation Measurement

Two-signal edge-separation measurement is similar to pulse-width measurement, except that there are two measurement signals—Aux and Gate. An active edge on the Aux input starts the counting and an active edge on the Gate input stops the counting. You must arm a counter to begin a two edge separation measurement.

After the counter has been armed and an active edge occurs on the Aux input, the counter counts the number of rising (or falling) edges on the Source. The counter ignores additional edges on the Aux input.

The counter stops counting upon receiving an active edge on the Gate input. The counter stores the count in a hardware save register.

You can configure the rising or falling edge of the Aux input to be the active edge. You can configure the rising or falling edge of the Gate input to be the active edge.

Use this type of measurement to count events or measure the time that occurs between edges on two signals. This type of measurement is sometimes referred to as start/stop trigger measurement, second gate measurement, or A-to-B measurement.

Single Two-Signal Edge-Separation Measurement

With single two-signal edge-separation measurement, the counter counts the number of rising (or falling) edges on the Source input occurring between an active edge of the Gate signal and an active edge of the Aux signal. The counter then stores the count in a hardware save register and ignores other edges on its inputs. Software then reads the stored count.

Figure 8-20 shows an example of a single two-signal edge-separation measurement.

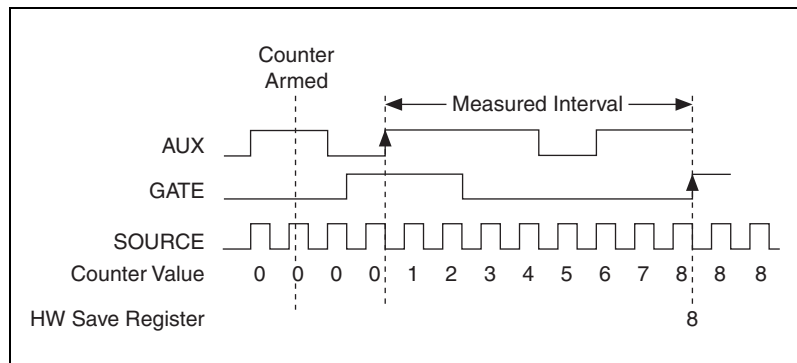

Figure 8-20. Single Two-Signal Edge-Separation Measurement

Buffered Two-Signal Edge-Separation Measurement

Buffered and single two-signal edge-separation measurements are similar, but buffered measurement measures multiple intervals.

The counter counts the number of rising (or falling) edges on the Source input occurring between an active edge of the Gate signal and an active edge of the Aux signal. The counter then stores the count in a hardware save register. On the next active edge of the Gate signal, the counter begins another measurement. A USB Signal Stream transfers the stored values to host memory.

Figure 8-21 shows an example of a buffered two-signal edge-separation measurement.

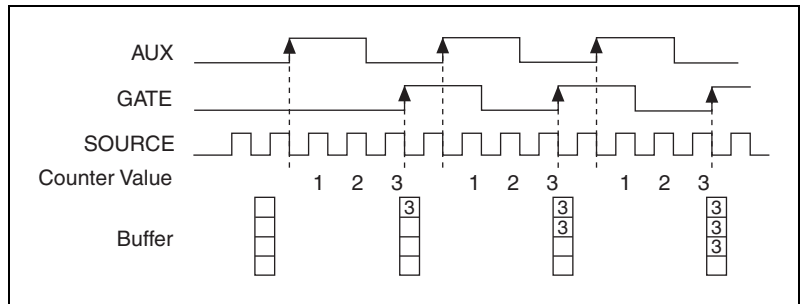

Figure 8-21. Buffered Two-Signal Edge-Separation Measurement

For information about connecting counter signals, refer to the [Default Counter/Timer Pinouts](#) section.

Counter Output Applications

Simple Pulse Generation

Single Pulse Generation

The counter can output a single pulse. The pulse appears on the Counter n Internal Output signal of the counter.

You can specify a delay from when the counter is armed to the beginning of the pulse. The delay is measured in terms of a number of active edges of the Source input.

You can specify a pulse width. The pulse width is also measured in terms of a number of active edges of the Source input. You also can specify the active edge of the Source input (rising or falling).

Figure 8-22 shows a generation of a pulse with a pulse delay of four and a pulse width of three (using the rising edge of Source).

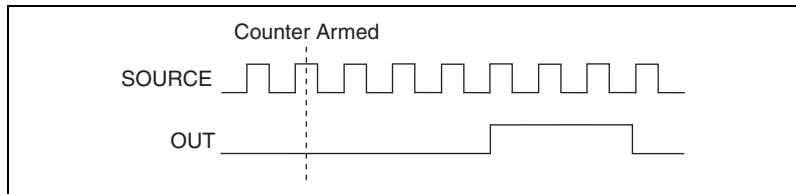

Figure 8-22. Single Pulse Generation

Single Pulse Generation with Start Trigger

The counter can output a single pulse in response to one pulse on a hardware Start Trigger signal. The pulse appears on the Counter n Internal Output signal of the counter.

You can route the Start Trigger signal to the Gate input of the counter. You can specify a delay from the Start Trigger to the beginning of the pulse. You also can specify the pulse width. The delay and pulse width are measured in terms of a number of active edges of the Source input.

After the Start Trigger signal pulses once, the counter ignores the Gate input.

Figure 8-23 shows a generation of a pulse with a pulse delay of four and a pulse width of three (using the rising edge of Source).

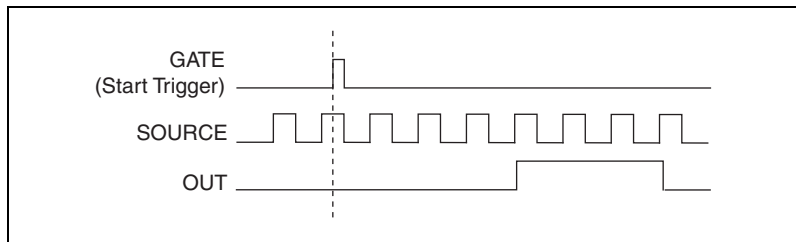

Figure 8-23. Single Pulse Generation with Start Trigger

Retriggerable Single Pulse Generation

The counter can output a single pulse in response to each pulse on a hardware Start Trigger signal. The pulses appear on the Counter n Internal Output signal of the counter.

You can route the Start Trigger signal to the Gate input of the counter. You can specify a delay from the Start Trigger to the beginning of each pulse. You also can specify the pulse width. The delay and pulse width are measured in terms of a number of active edges of the Source input.

The counter ignores the Gate input while a pulse generation is in progress. After the pulse generation is finished, the counter waits for another Start Trigger signal to begin another pulse generation.

Figure 8-24 shows a generation of two pulses with a pulse delay of five and a pulse width of three (using the rising edge of Source).

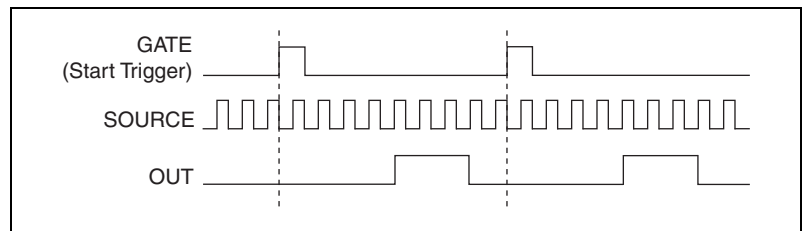

Figure 8-24. Retriggerable Single Pulse Generation

For information about connecting counter signals, refer to the [Default Counter/Timer Pinouts](#) section.

Pulse Train Generation

Continuous Pulse Train Generation

This function generates a train of pulses with programmable frequency and duty cycle. The pulses appear on the Counter *n* Internal Output signal of the counter.

You can specify a delay from when the counter is armed to the beginning of the pulse train. The delay is measured in terms of a number of active edges of the Source input.

You specify the high and low pulse widths of the output signal. The pulse widths are also measured in terms of a number of active edges of the Source input. You also can specify the active edge of the Source input (rising or falling).

The counter can begin the pulse train generation as soon as the counter is armed, or in response to a hardware start trigger. You can route the Start Trigger to the Gate input of the counter.

You also can use the Gate input of the counter as a Pause Trigger (if it is not used as a Start Trigger). The counter pauses pulse generation when the Pause Trigger is active.

Figure 8-25 shows a continuous pulse train generation (using the rising edge of Source).

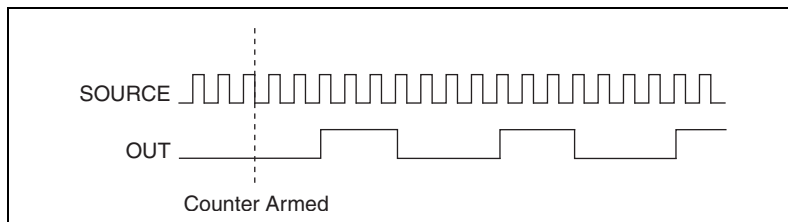

Figure 8-25. Continuous Pulse Train Generation

Continuous pulse train generation is sometimes called frequency division. If the high and low pulse widths of the output signal are M and N periods, then the frequency of the Counter n Internal Output signal is equal to the frequency of the Source input divided by $M + N$.

For information about connecting counter signals, refer to the [Default Counter/Timer Pinouts](#) section.

Finite Pulse Train Generation

This function generates a train of pulses of predetermined duration. This counter operation requires both counters. The first counter (for this example, Counter 0) generates a pulse of desired width. The second counter, Counter 1, generates the pulse train, which is gated by the pulse of the first counter. The routing is done internally. Figure 8-26 shows an example finite pulse train timing diagram.

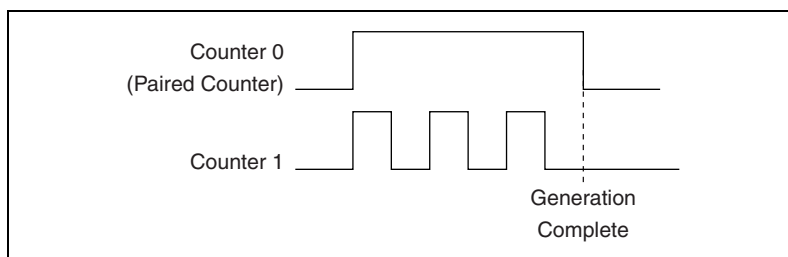

Figure 8-26. Finite Pulse Train Timing Diagram

Frequency Generation

You can generate a frequency by using a counter in pulse train generation mode or by using the frequency generator circuit.

Using the Frequency Generator

The frequency generator can output a square wave at many different frequencies. The frequency generator is independent of the two general-purpose 32-bit counter/timer modules on USB-621x devices.

Figure 8-27 shows a block diagram of the frequency generator.

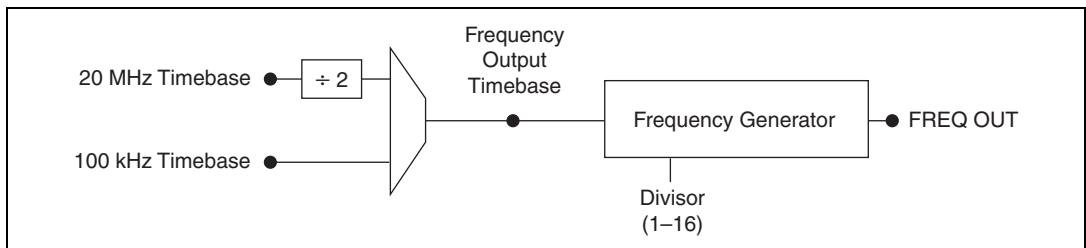

Figure 8-27. Frequency Generator Block Diagram

The frequency generator generates the Frequency Output signal. The Frequency Output signal is the Frequency Output Timebase divided by a number you select from 1 to 16. The Frequency Output Timebase can be either the 20 MHz Timebase divided by 2 or the 100 kHz Timebase.

The duty cycle of Frequency Output is 50% if the divider is either 1 or an even number. For an odd divider, suppose the divider is set to D . In this case, Frequency Output is low for $(D + 1)/2$ cycles and high for $(D - 1)/2$ cycles of the Frequency Output Timebase.

Figure 8-28 shows the frequency generator output waveform when the divider is set to 5.

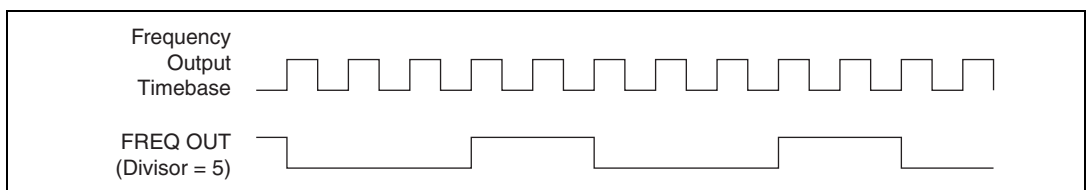

Figure 8-28. Frequency Generator Output Waveform

Frequency Output can be routed out to any output PFI terminal. All PFI terminals are set to high-impedance at startup. The **FREQ OUT** signal also can be routed to **DO Sample Clock** and **DI Sample Clock**.

In software, program the frequency generator as you would program one of the counters for pulse train generation.

For information about connecting counter signals, refer to the [Default Counter/Timer Pinouts](#) section.

Frequency Division

The counters can generate a signal with a frequency that is a fraction of an input signal. This function is equivalent to continuous pulse train generation.

For information about connecting counter signals, refer to the [Default Counter/Timer Pinouts](#) section.

Pulse Generation for ETS

In the equivalent time sampling (ETS) application, the counter produces a pulse on the output a specified delay after an active edge on Gate. After each active edge on Gate, the counter cumulatively increments the delay between the Gate and the pulse on the output by a specified amount. Thus, the delay between the Gate and the pulse produced successively increases.

The increase in the delay value can be between 0 and 255. For instance, if you specify the increment to be 10, the delay between the active Gate edge and the pulse on the output increases by 10 every time a new pulse is generated.

Suppose you program your counter to generate pulses with a delay of 100 and pulse width of 200 each time it receives a trigger. Furthermore, suppose you specify the delay increment to be 10. On the first trigger, your pulse delay is 100, on the second it is 110, on the third it is 120; the process repeats in this manner until the counter is disarmed. The counter ignores any Gate edge that is received while the pulse triggered by the previous Gate edge is in progress.

The waveform thus produced at the counter's output can be used to provide timing for undersampling applications where a digitizing system can sample repetitive waveforms that are higher in frequency than the Nyquist

frequency of the system. Figure 8-29 shows an example of pulse generation for ETS; the delay from the trigger to the pulse increases after each subsequent Gate active edge.

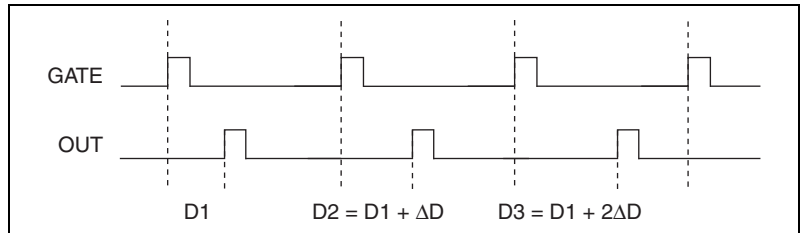

Figure 8-29. Pulse Generation for ETS

For information about connecting counter signals, refer to the [Default Counter/Timer Pinouts](#) section.

Counter Timing Signals

USB-621x devices feature the following counter timing signals:

- [Counter *n* Source Signal](#)
- [Counter *n* Gate Signal](#)
- [Counter *n* Aux Signal](#)
- [Counter *n* A Signal](#)
- [Counter *n* B Signal](#)
- [Counter *n* Z Signal](#)
- [Counter *n* Up_Down Signal](#)
- [Counter *n* HW Arm Signal](#)
- [Counter *n* Internal Output Signal](#)
- [Counter *n* TC Signal](#)
- [Frequency Output Signal](#)

In this section, *n* refers to either Counter 0 or 1. For example, Counter *n* Source refers to two signals—Counter 0 Source (the source input to Counter 0) and Counter 1 Source (the source input to Counter 1).

Counter n Source Signal

The selected edge of the Counter n Source signal increments and decrements the counter value depending on the application the counter is performing. Table 8-3 lists how this terminal is used in various applications.

Table 8-3. Counter Applications and Counter n Source

Application	Purpose of Source Terminal
Pulse Generation	Counter Timebase
One Counter Time Measurements	Counter Timebase
Two Counter Time Measurements	Input Terminal
Non-Buffered Edge Counting	Input Terminal
Buffered Edge Counting	Input Terminal
Two-Edge Separation	Counter Timebase

Routing a Signal to Counter n Source

Each counter has independent input selectors for the Counter n Source signal. Any of the following signals can be routed to the Counter n Source input:

- 80 MHz Timebase
- 20 MHz Timebase
- 100 kHz Timebase
- **(USB-6210/6211/6215 Devices)** PFI <0..3>
- **(USB-6212/6216 Devices)** PFI <0..15>
- **(USB-6218 Devices)** PFI <0..3>, PFI <8..11>

In addition, Counter 1 TC or Counter 1 Gate can be routed to Counter 0 Source. Counter 0 TC or Counter 0 Gate can be routed to Counter 1 Source.

Some of these options may not be available in some driver software.

Routing Counter n Source to an Output Terminal

You can route Counter n Source out to any output PFI terminal.

Counter n Gate Signal

The Counter n Gate signal can perform many different operations depending on the application including starting and stopping the counter, and saving the counter contents.

Routing a Signal to Counter n Gate

Each counter has independent input selectors for the Counter n Gate signal. Any of the following signals can be routed to the Counter n Gate input:

- **(USB-6210/6211/6215 Devices)** PFI <0..3>
- **(USB-6212/6216 Devices)** PFI <0..15>
- **(USB-6218 Devices)** PFI <0..3>, PFI <8..11>
- AI Reference Trigger (ai/ReferenceTrigger)
- AI Start Trigger (ai/StartTrigger)
- AI Sample Clock (ai/SampleClock)
- AI Convert Clock (ai/ConvertClock)
- AO Sample Clock (ao/SampleClock)

In addition, Counter 1 Internal Output or Counter 1 Source can be routed to Counter 0 Gate. Counter 0 Internal Output or Counter 0 Source can be routed to Counter 1 Gate.

Some of these options may not be available in some driver software.

Routing Counter n Gate to an Output Terminal

You can route Counter n Gate out to any output PFI terminal.

Counter n Aux Signal

The Counter n Aux signal indicates the first edge in a two-signal edge-separation measurement.

Routing a Signal to Counter n Aux

Each counter has independent input selectors for the Counter n Aux signal. Any of the following signals can be routed to the Counter n Aux input:

- **(USB-6210/6211/6215 Devices)** PFI <0..3>
- **(USB-6212/6216 Devices)** PFI <0..15>
- **(USB-6218 Devices)** PFI <0..3>, PFI <8..11>

- AI Reference Trigger (ai/ReferenceTrigger)
- AI Start Trigger (ai/StartTrigger)

In addition, Counter 1 Internal Output, Counter 1 Gate, Counter 1 Source, or Counter 0 Gate can be routed to Counter 0 Aux. Counter 0 Internal Output, Counter 0 Gate, Counter 0 Source, or Counter 1 Gate can be routed to Counter 1 Aux.

Some of these options may not be available in some driver software.

Counter n A, Counter n B, and Counter n Z Signals

Counter n B can control the direction of counting in edge counting applications. Use the A, B, and Z inputs to each counter when measuring quadrature encoders or measuring two pulse encoders.

Routing Signals to A, B, and Z Counter Inputs

Each counter has independent input selectors for each of the A, B, and Z inputs. You can route any input PFI signal to each input.

Counter n Up_Down Signal

Counter n Up_Down is another name for the Counter n B signal.

Counter n HW Arm Signal

The Counter n HW Arm signal enables a counter to begin an input or output function.

To begin any counter input or output function, you must first enable, or arm, the counter. In some applications, such as buffered semi-period measurement, the counter begins counting when it is armed. In other applications, such as single pulse-width measurement, the counter begins waiting for the Gate signal when it is armed. Counter output operations can use the arm signal in addition to a start trigger.

Software can arm a counter or configure counters to be armed on a hardware signal. Software calls this hardware signal the Arm Start Trigger. Internally, software routes the Arm Start Trigger to the Counter n HW Arm input of the counter.

Routing Signals to Counter n HW Arm Input

Any of the following signals can be routed to the Counter n HW Arm input:

- **(USB-6210/6211/6215 Devices)** PFI <0..3>
- **(USB-6212/6216 Devices)** PFI <0..15>
- **(USB-6218 Devices)** PFI <0..3>, PFI <8..11>
- AI Reference Trigger (ai/ReferenceTrigger)
- AI Start Trigger (ai/StartTrigger)

Counter 1 Internal Output can be routed to Counter 0 HW Arm. Counter 0 Internal Output can be routed to Counter 1 HW Arm.

Some of these options may not be available in some driver software.

Counter n Internal Output and Counter n TC Signals

The Counter n Internal Output signal changes in response to Counter n TC.

The two software-selectable output options are pulse output on TC and toggle output on TC. The output polarity is software-selectable for both options.

With pulse or pulse train generation tasks, the counter drives the pulse(s) on the Counter n Internal Output signal. The Counter n Internal Output signal can be internally routed to be a counter/timer input or an “external” source for AI, AO, DI, or DO timing signals.

Routing Counter n Internal Output to an Output Terminal

You can route Counter n Internal Output to any output PFI terminal.

Frequency Output Signal

The Frequency Output (FREQ OUT) signal is the output of the frequency output generator.

Routing Frequency Output to a Terminal

You can route Frequency Output to any output PFI terminal.

Default Counter/Timer Pinouts

By default, NI-DAQmx routes the counter/timer inputs and outputs to the USB-6210/6211/6215 device PFI pins as shown in Table 8-4.

Table 8-4. Default NI-DAQmx Counter/Timer Pins for USB-6210/6211/6215 Devices

Counter/Timer Signal	Default Terminal Number (Name)
CTR 0 SRC	1 (PFI 0)
CTR 0 GATE	2 (PFI 1)
CTR 0 AUX	1 (PFI 0)
CTR 0 OUT	6 (PFI 4)
CTR 0 A	1 (PFI 0)
CTR 0 Z	3 (PFI 2)
CTR 0 B	2 (PFI 1)
CTR 1 SRC	4 (PFI 3)
CTR 1 GATE	3 (PFI 2)
CTR 1 AUX	4 (PFI 3)
CTR 1 OUT	7 (PFI 5)
CTR 1 A	4 (PFI 3)
CTR 1 Z	2 (PFI 1)
CTR 1 B	3 (PFI 2)
FREQ OUT	8 (PFI 6)



Note You can find the default NI-DAQmx counter/timer pins for all USB-621x devices in the applicable section of Appendix A, *Device-Specific Information*.

You can use these defaults or select other sources and destinations for the counter/timer signals in NI-DAQmx. Refer to *Connecting Counter Signals* in the *NI-DAQmx Help* or the *LabVIEW Help* in version 8.0 or later for more information about how to connect your signals for common counter measurements and generations. USB-621x default PFI lines for counter functions are listed in *Physical Channels* in the *NI-DAQmx Help* or the *LabVIEW Help* in version 8.0 or later.

Counter Triggering

Counters support three different triggering actions:

- **Arm Start Trigger**—To begin any counter input or output function, you must first enable, or arm, the counter. Software can arm a counter or configure counters to be armed on a hardware signal. Software calls this hardware signal the Arm Start Trigger. Internally, software routes the Arm Start Trigger to the Counter n HW Arm input of the counter.

For counter output operations, you can use the arm start trigger in addition to the start and pause triggers. For counter input operations, you can use the arm start trigger to have start trigger-like behavior. The arm start trigger can be used for synchronizing multiple counter input and output tasks.

When using an arm start trigger, the arm start trigger source is routed to the Counter n HW Arm signal.

- **Start Trigger**—For counter output operations, a start trigger can be configured to begin a finite or continuous pulse generation. Once a continuous generation has triggered, the pulses continue to generate until you stop the operation in software. For finite generations, the specified number of pulses is generated and the generation stops unless you use the retriggerable attribute. When you use this attribute, subsequent start triggers cause the generation to restart.

When using a start trigger, the start trigger source is routed to the Counter n Gate signal input of the counter.

Counter input operations can use the arm start trigger to have start trigger-like behavior.

- **Pause Trigger**—You can use pause triggers in edge counting and continuous pulse generation applications. For edge counting acquisitions, the counter stops counting edges while the external trigger signal is low and resumes when the signal goes high or vice versa. For continuous pulse generations, the counter stops generating pulses while the external trigger signal is low and resumes when the signal goes high or vice versa.

When using a pause trigger, the pause trigger source is routed to the Counter n Gate signal input of the counter.

Other Counter Features

Sample Clock

When taking counter measurements, you can enable a sample clock. When you use a sample clock, measurements are saved after an active edge of the sample clock. Figure 8-30 shows an example of using a sample clock with a buffered period measurement. In this example, a period is defined by two consecutive rising edges of the Gate.

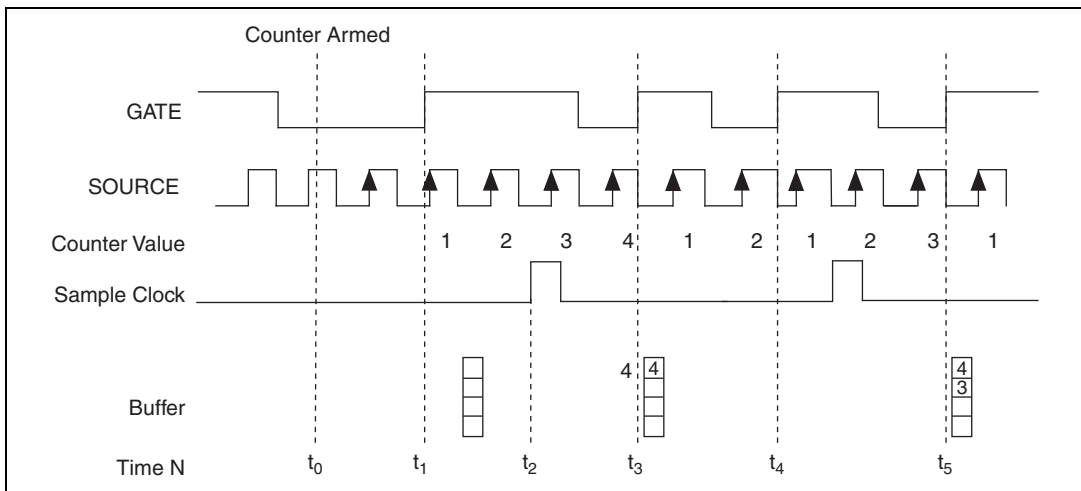

- t_0 At t_0 , the counter is armed. No measurements are taken until the counter is armed.
- t_1 The rising edge of Gate indicates the beginning of the first period to measure. The counter begins counting rising edges of Source.
- t_2 The rising edge of Sample Clock indicates that the USB-621x device should store the result of the measurement of the current period when the period ends.
- t_3 The rising edge of Gate indicates the end of the first period. The USB-621x device stores the counter value in the buffer.
- t_4 The rising edge of Gate indicates the end of the second period. Sample Clock did not assert during this period, so the counter discards the measurement of the second period.
- t_5 The rising edge of Gate indicates the end of the third period. Sample Clock asserts during this period, so the USB-621x device stores the measurement in the buffer.

Figure 8-30. Sample Clock Example

Cascading Counters

You can internally route the Counter n Internal Output and Counter n TC signals of each counter to Gate inputs of the other counter. By cascading two counters together, you can effectively create a 64-bit counter. By cascading counters, you also can enable other applications. For example, to improve the accuracy of frequency measurements, use reciprocal frequency measurement, as described in the [Method 3](#) bullet of the [Frequency Measurement](#) section.

Counter Filters

You can enable a programmable debouncing filter on each PFI signal. When the filters are enabled, your device samples the input on each rising edge of a filter clock. USB-621x devices use an onboard oscillator to generate the filter clock with a 40 MHz frequency.



Note NI-DAQmx *only* supports filters on counter inputs.

The following is an example of low-to-high transitions of the input signal. High-to-low transitions work similarly.

Assume that an input terminal has been low for a long time. The input terminal then changes from low-to-high, but glitches several times. When the filter clock has sampled the signal high on N consecutive edges, the low-to-high transition is propagated to the rest of the circuit. The value of N depends on the filter setting; refer to Table 8-5.

Table 8-5. Filters

Filter Setting	N (Filter Clocks Needed to Pass Signal)	Pulse Width Guaranteed to Pass Filter	Pulse Width Guaranteed to Not Pass Filter
125 ns	5	125 ns	100 ns
6.425 μ s	257	6.425 μ s	6.400 μ s
2.56 ms	~101,800	2.56 ms	2.54 ms
Disabled	—	—	—

The filter setting for each input can be configured independently. On power up, the filters are disabled. Figure 8-31 shows an example of a low-to-high transition on an input that has its filter set to 125 ns ($N = 5$).

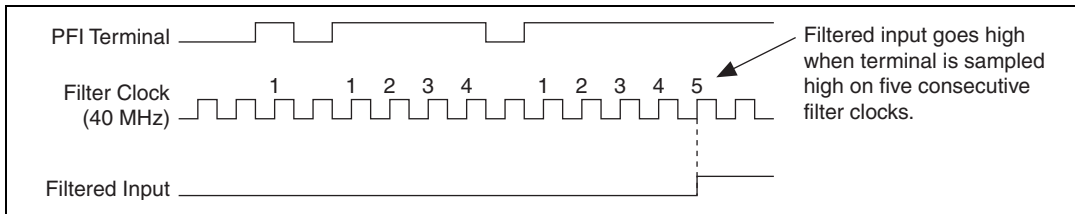

Figure 8-31. Filter Example

Enabling filters introduces jitter on the input signal. For the 125 ns and 6.425 μ s filter settings, the jitter is up to 25 ns. On the 2.56 ms setting, the jitter is up to 10.025 μ s.

Refer to the KnowledgeBase document, *Digital Filtering with M Series and CompactDAQ*, for more information about digital filters and counters. To access this KnowledgeBase, go to ni.com/info and enter the info code rddfms.

Prescaling

Prescaling allows the counter to count a signal that is faster than the maximum timebase of the counter. USB-621x devices offer 8X and 2X prescaling on each counter (prescaling can be disabled). Each prescaler consists of a small, simple counter that counts to eight (or two) and rolls over. This counter can run faster than the larger counters, which simply count the rollovers of this smaller counter. Thus, the prescaler acts as a frequency divider on the Source and puts out a frequency that is one-eighth (or one-half) of what it is accepting.

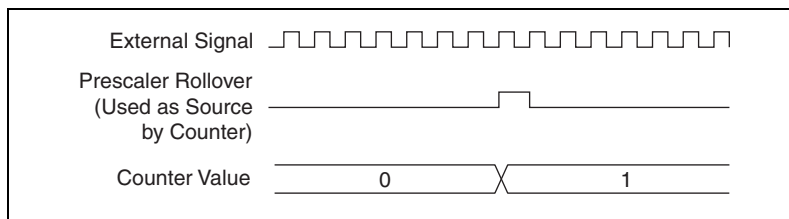

Figure 8-32. Prescaling

Prescaling is intended to be used for frequency measurement where the measurement is made on a continuous, repetitive signal. The prescaling counter cannot be read; therefore, you cannot determine how many edges have occurred since the previous rollover. Prescaling can be used for event counting provided it is acceptable to have an error of up to seven (or one). Prescaling can be used when the counter Source is an external signal.

Prescaling is not available if the counter Source is one of the internal timebases (80MHzTimebase, 20MHzTimebase, or 100kHzTimebase).

Duplicate Count Prevention

Duplicate count prevention (or synchronous counting mode) is used when taking frequency or period measurements on USB-621x devices, which ensures that a counter returns correct data in applications that use a slow or non-periodic external source. Duplicate count prevention applies only to buffered counter applications, such as measuring frequency or period. In such buffered applications, the counter should store the number of times an external Source pulses between rising edges on the Gate signal.

Example Application That Works Correctly (No Duplicate Counting)

Figure 8-33 shows an external buffered signal as the period measurement Source.

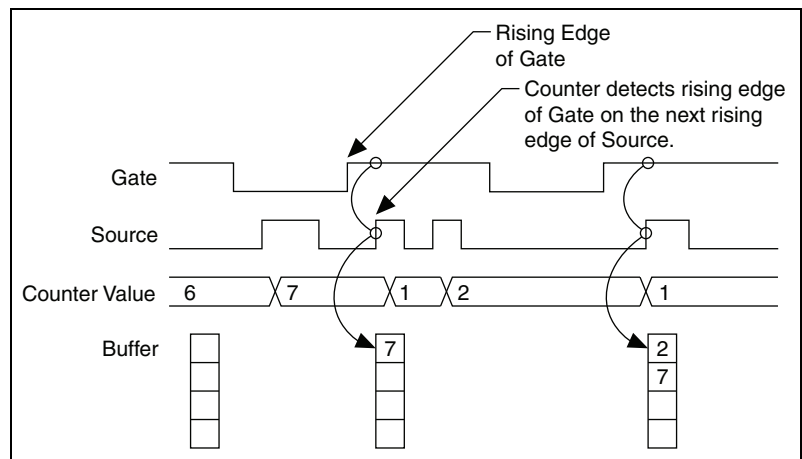

Figure 8-33. Duplicate Count Prevention Example

On the first rising edge of Gate, the current count of 7 is stored. On the next rising edge of Gate, the counter stores a 2 since two Source pulses occurred after the previous rising edge of Gate.

The counter synchronizes or samples the Gate signal with the Source signal, so the counter does not detect a rising edge in Gate until the next Source pulse. In this example, the counter stores the values in the buffer on

the first rising Source edge after the rising edge of Gate. The details of when exactly the counter synchronizes the Gate signal vary depending on the synchronization mode.

Example Application That Works Incorrectly (Duplicate Counting)

In Figure 8-34, after the first rising edge of Gate, no Source pulses occur, so the counter does not write the correct data to the buffer.

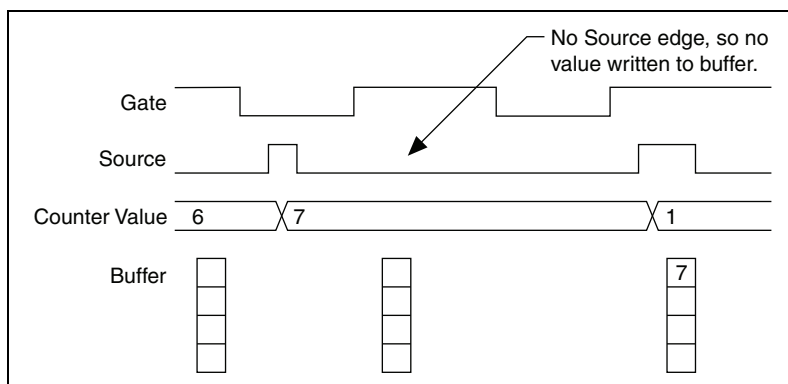

Figure 8-34. Duplicate Count Example

Example Application That Prevents Duplicate Count

With duplicate count prevention, the counter synchronizes both the Source and Gate signals to the 80 MHz Timebase. By synchronizing to the timebase, the counter detects edges on Gate even if the Source does not pulse. This enables the correct current count to be stored in the buffer even if no Source edges occur between Gate signals, as shown in Figure 8-35.

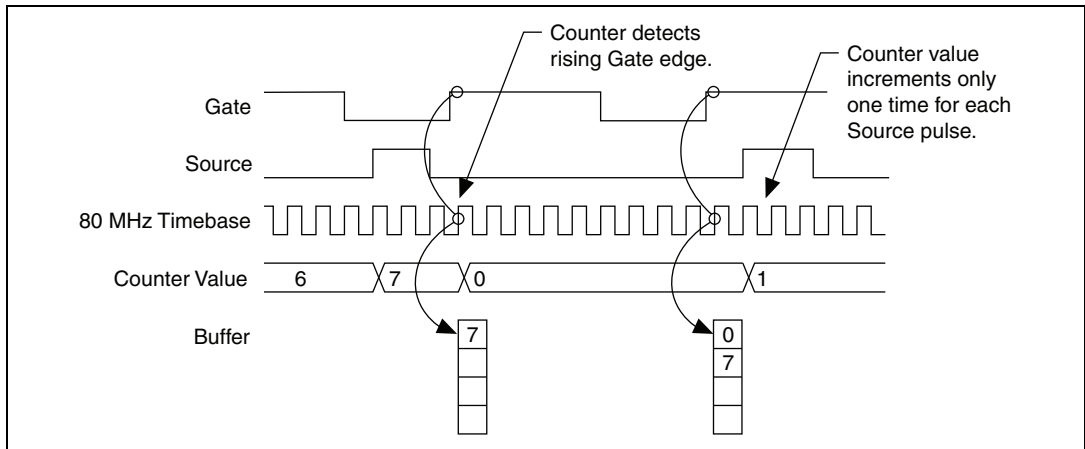

Figure 8-35. Duplicate Count Prevention Example

Even if the Source pulses are long, the counter increments only once for each Source pulse.

Normally, the counter value and Counter n Internal Output signals change synchronously to the Source signal. With duplicate count prevention, the counter value and Counter n Internal Output signals change synchronously to the 80 MHz Timebase.

Enabling Duplicate Count Prevention in NI-DAQmx

Duplicate count prevention is automatically used with USB-621x devices. Disabling duplicate count prevention is not supported.

Isolation and Digital Isolators on USB-6215/6216/6218 Devices

USB-6215/6216/6218 devices are isolated data acquisition devices. The analog input, analog output, counters, PFI/static DI, and PFI/static DO circuitry¹, and digital routing and clock generation are referenced to an isolated ground, as shown in Figure 9-1.

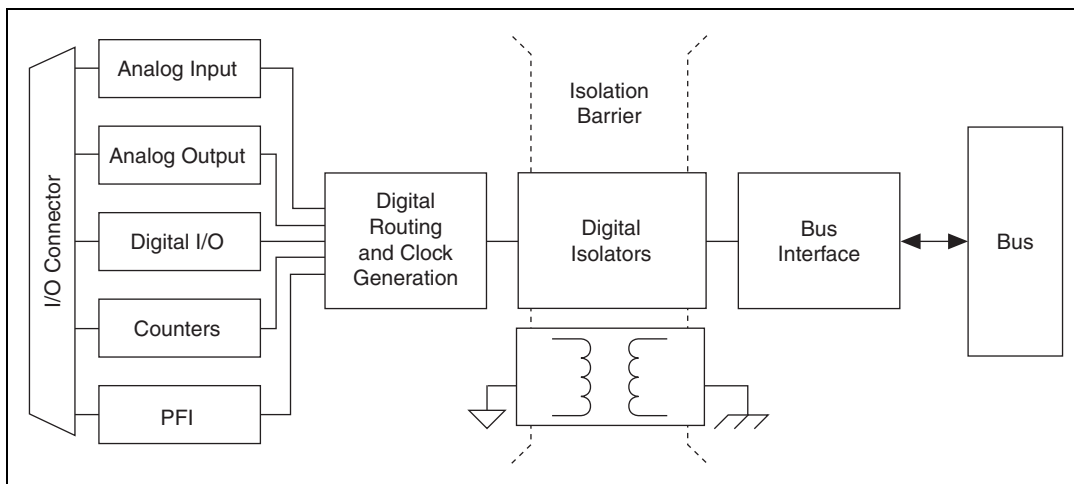

Figure 9-1. USB-6215/6216/6218 Block Diagram

The bus interface circuitry is referenced to a non-isolated ground. The following table lists the ground symbols.

Ground Type	Symbol
Isolated Ground	
Non-Isolated Ground	

¹ USB-6216 devices have PFI/static DIO circuitry.

The non-isolated ground is connected to the chassis ground of the PC.

Each isolated ground is *not* connected to the chassis ground of the PC. The isolated ground can be at a higher or lower voltage relative to the non-isolated ground. All analog measurements are made relative to the isolated ground signal.

The isolated ground is an input to the USB-6215/6216/6218 device. The user *must* connect this ground to the ground of system being measured or controlled. For more information, refer to the following:

- The [Connecting Analog Input Signals on USB-6215/6216/6218 Devices](#) section of Chapter 4, [Analog Input](#)
- The [Connecting Analog Output Signals](#) section of Chapter 5, [Analog Output](#)
- The [Connecting Digital I/O Signals on USB-6210/6211/6215/6218 Devices](#) or [Connecting Digital I/O Signals on USB-6212/6216 Devices](#) section of Chapter 6, [Digital I/O](#)
- The [Connecting PFI Input Signals](#) section of Chapter 7, [PFI](#)

Digital Isolation

USB-6215/6216/6218 devices use digital isolators. Unlike analog isolators, digital isolators do not introduce any analog error in the measurements taken by the device. The A/D converter, used for analog input, is on the isolated side of the device. The analog inputs are digitized before they are sent across the isolation barrier. Similarly, the D/A converters, used for analog output, are on the isolated side of the device.

Benefits of an Isolated DAQ Device

With isolation, engineers can safely measure a small signal in the presence of a large common-mode voltage signal. Some advantages of isolation are as follows:

- **Improved Rejection**—Isolation increases the ability of the measurement system to reject common-mode voltages. Common-mode voltage is the signal that is present or “common” to both the positive and negative input of a measurement device, but is not part of the signal to be measured.
- **Improved Accuracy**—Isolation improves measurement accuracy by physically preventing ground loops. Ground loops, a common source

of error and noise, are the result of a measurement system having multiple grounds at different potentials.

- **Improved Safety**—The isolation barrier allows you to make floating measurements while protecting the USB host computer against large transient voltage spikes.

Reducing Common-Mode Noise

Isolated products require an isolated power supply to deliver power to the isolated side from the non-isolated side. Isolated power supplies work by switching voltages through a transformer with high-speed transistors. Switching voltages through the transformer cause charging and discharging of the parasitic capacitances and inductances in the switching power supplies that occur on every switch cycle, resulting in high-speed currents flowing through the isolated side and returning to the non-isolated side, which is earth ground.

These parasitic currents interact with parasitic and non-parasitic resistances causing voltage spikes. These voltage spikes are called common-mode noise, a noise source that travels in the ground and is therefore common to both the ground and any signal referenced to the ground, such as AI, AO, and digital signals. Common-mode noise appears at the harmonics of the switching power supply frequency and can corrupt measurements depending on the system setup.

You can perform some tasks to reduce common-mode noise:

- Better grounding from the front connector AI GND to the signal source ground can reduce common-mode noise. Use low resistance cabling and connections and verify that all ground connections are kept short. Keep the number of connections to a minimum. If the device's isolated ground is being connected back to earth ground, verify that this is done in the most direct way possible.
- Reduce source impedances if possible. The parasitic currents react with these impedances.

Creating an AC Return Path



Caution Adding a capacitor will degrade the USB-6215/6216/6218 device withstand voltage and isolation specifications. Withstand voltage *must* be retested by an approved testing facility after adjustments are made to the measurement system.

Isolated Systems

A fully isolated measurement system is one where the device's isolated front end is not connected back to earth ground.

Create an AC path back to earth ground from the device's isolated ground by connecting a high voltage capacitor between the isolated board ground and earth ground. The voltage rating of the capacitor must be larger than the voltage drop between the isolated ground and earth ground.

Non-Isolated Systems

A non-isolated measurement system is one where the device's isolated front end connects to earth ground.

Add an AC return path from the device isolated ground to earth ground. For non-isolated systems, an AC return path is only needed for high or source impedances. An AC return path can be created by connecting a capacitor between the device's isolated ground and earth ground.

Digital Routing and Clock Generation

The digital routing circuitry has the following main functions:

- Manages the flow of data between the bus interface and the acquisition/generation sub-systems (analog input, analog output, digital I/O, and the counters). The digital routing circuitry uses FIFOs (if present) in each sub-system to ensure efficient data movement.
- Routes timing and control signals. The acquisition/generation sub-systems use these signals to manage acquisitions and generations. These signals can come from the following sources:
 - Your USB-621x device
 - User input through the PFI terminals
- Routes and generates the main clock signals for the USB-621x device.

80 MHz Timebase

The 80 MHz Timebase can be used as the Source input to the 32-bit general-purpose counter/timers. The 80 MHz Timebase is generated from the onboard oscillator.

20 MHz Timebase

The 20 MHz Timebase normally generates many of the AI and AO timing signals. The 20 MHz Timebase also can be used as the Source input to the 32-bit general-purpose counter/timers. The 20 MHz Timebase is generated by dividing down the 80 MHz Timebase.

100 kHz Timebase

The 100 kHz Timebase can be used to generate many of the AI and AO timing signals. The 100 kHz Timebase also can be used as the Source input to the 32-bit general-purpose counter/timers. The 100 kHz Timebase is generated by dividing down the 20 MHz Timebase by 200.

Bus Interface

The bus interface circuitry of USB-621x devices efficiently moves data between host memory and the measurement and acquisition circuits.

All USB-621x devices are jumperless for complete plug-and-play operation. The operating system automatically assigns the base address, interrupt levels, and other resources.

USB-621x devices incorporate USB-STC2 technology to implement a Hi-Speed USB interface.

USB Signal Stream

USB-621x devices have four fully-independent USB Signal Streams for high-performance transfers of data blocks. One USB Signal Stream is available for each measurement and acquisition block:

- Analog input
- Analog output
- Counter 0
- Counter 1

Data Transfer Methods

The two primary ways to transfer data across the USB bus are as follows:

- **USB Signal Stream**—A method to transfer data between the device and computer memory using USB bulk transfers without intervention of the microcontroller on the NI device. NI uses USB Signal Stream hardware and software technology to achieve high throughput rates and increase system utilization in USB devices.
- **Programmed I/O**—A data transfer mechanism where the user's program is responsible for transferring data. Each read or write call in the program initiates the transfer of data. Programmed I/O is typically used in software-timed (on-demand) operations. Refer to the [Analog Output Data Generation Methods](#) section of Chapter 5, [Analog Output](#), for more information.

Changing Data Transfer Methods

USB-621x devices have four dedicated USB Signal Stream channels. To change your data transfer mechanism between USB Signal Streams and programmed I/O, use the **Data Transfer Mechanism** property node function in NI-DAQmx.

Triggering

A trigger is a signal that causes an action, such as starting or stopping the acquisition of data. When you configure a trigger, you must decide how you want to produce the trigger and the action you want the trigger to cause. All USB-621x devices support internal software triggering, as well as external digital triggering. For information about the different actions triggers can perform for each sub-system of the device, refer to the following sections:

- The *Analog Input Digital Triggering* section of Chapter 4, *Analog Input*
- The *Analog Output Digital Triggering* section of Chapter 5, *Analog Output*
- The *Counter Triggering* section of Chapter 8, *Counters*

Triggering with a Digital Source

Your USB-621x device can generate a trigger on a digital signal. You must specify a source and an edge. The digital source can be any input PFI signal.

The edge can be either the rising edge or falling edge of the digital signal. A rising edge is a transition from a low logic level to a high logic level. A falling edge is a high to low transition. Figure 12-1 shows a falling-edge trigger.

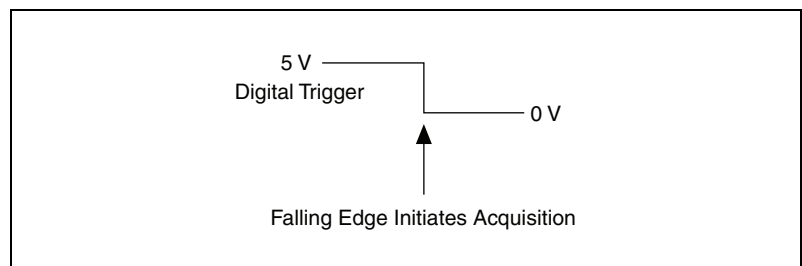

Figure 12-1. Falling-Edge Trigger

You also can program your USB-621*x* device to perform an action in response to a trigger from a digital source. The action can affect the following:

- Analog input acquisition
- Analog output generation
- Counter behavior

Device-Specific Information

This appendix contains device pinouts and other information for the following USB-621x devices:

- [*USB-6210*](#)
- [*USB-6211/6215*](#)
- [*USB-6212/6216 Screw Terminal*](#)
- [*USB-6212/6216 Mass Termination*](#)
- [*USB-6212/6216 BNC*](#)
- [*USB-6218 Screw Terminal*](#)
- [*USB-6218 BNC*](#)

Refer to the *NI USB-621x Specifications*, available on the NI-DAQ Device Documentation Browser or from ni.com/manuals, for more detailed information about USB-621x devices.

To obtain documentation for devices not listed here, refer to ni.com/manuals.

USB-6210

USB-6210 Pinout

Figure A-1 shows the pinout of the USB-6210.

For a detailed description of each signal, refer to the *I/O Connector Signal Descriptions* section of Chapter 3, *Connector and LED Information*.

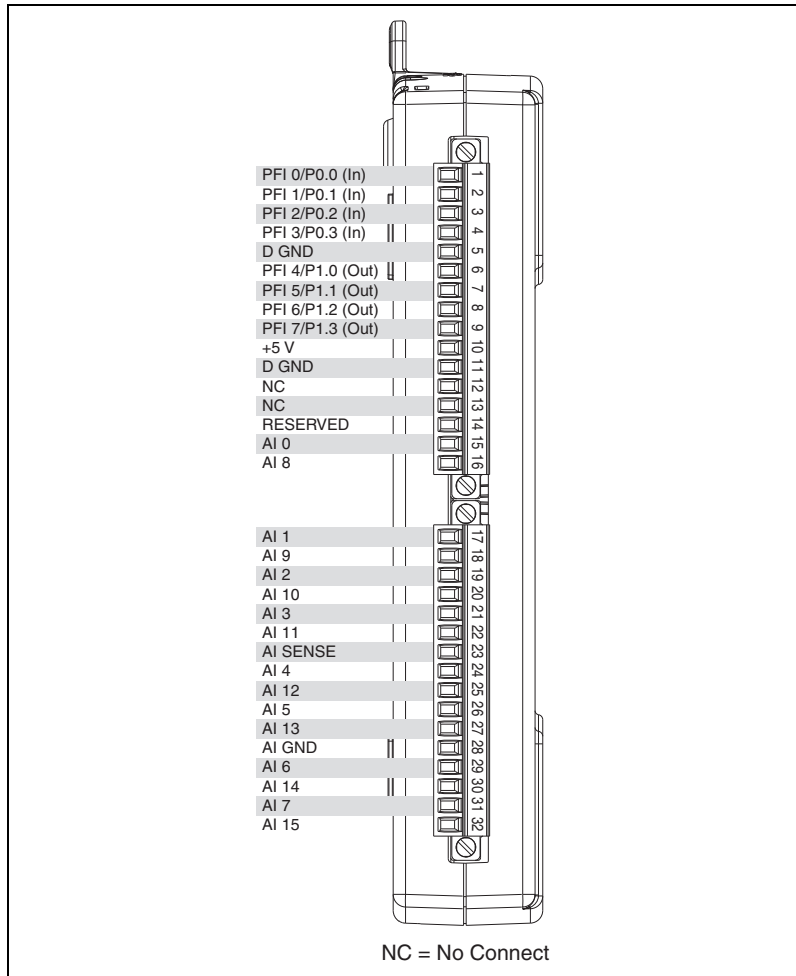

Figure A-1. USB-6210 Pinout

Table A-1. Default NI-DAQmx Counter/Timer Pins

Counter/Timer Signal	Default Terminal Number (Name)
CTR 0 SRC	1 (PFI 0)
CTR 0 GATE	2 (PFI 1)
CTR 0 AUX	1 (PFI 0)
CTR 0 OUT	6 (PFI 4)
CTR 0 A	1 (PFI 0)
CTR 0 Z	3 (PFI 2)
CTR 0 B	2 (PFI 1)
CTR 1 SRC	4 (PFI 3)
CTR 1 GATE	3 (PFI 2)
CTR 1 AUX	4 (PFI 3)
CTR 1 OUT	7 (PFI 5)
CTR 1 A	4 (PFI 3)
CTR 1 Z	2 (PFI 1)
CTR 1 B	3 (PFI 2)
FREQ OUT	8 (PFI 6)



Note For more information about default NI-DAQmx counter inputs, refer to *Connecting Counter Signals* in the *NI-DAQmx Help* or the *LabVIEW Help* in version 8.0 or later.

USB-6211/6215

USB-6211/6215 Pinout

Figure A-2 shows the pinout of the USB-6211 and USB-6215.

For a detailed description of each signal, refer to the *I/O Connector Signal Descriptions* section of Chapter 3, *Connector and LED Information*.

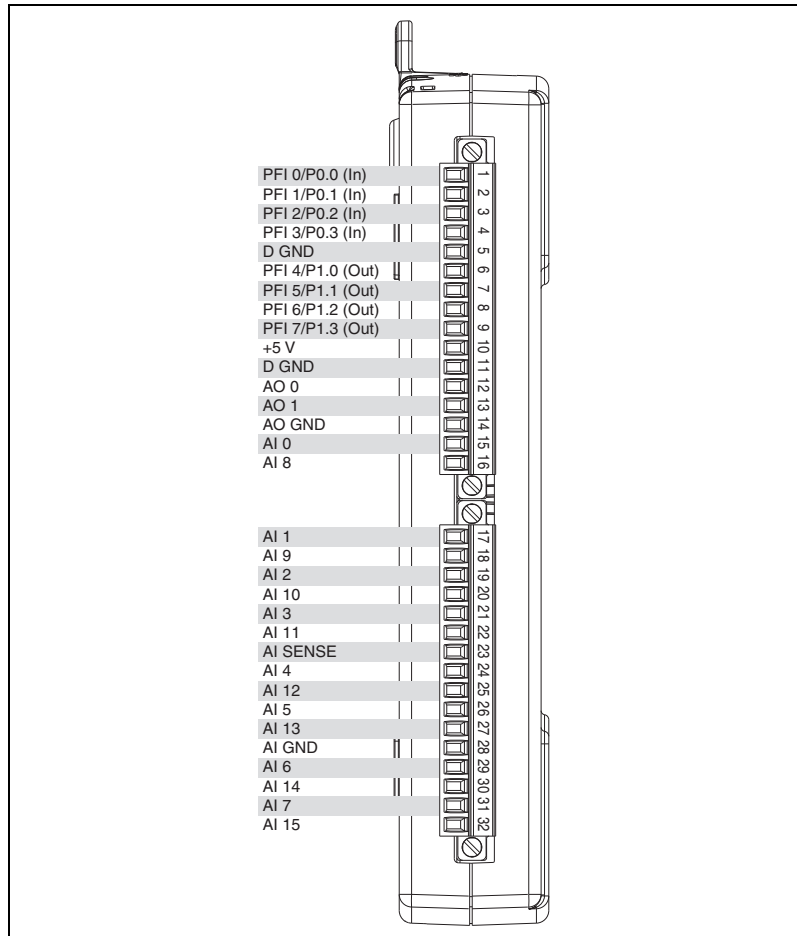

Figure A-2. USB-6211/6215 Pinout

Table A-2. Default NI-DAQmx Counter/Timer Pins

Counter/Timer Signal	Default Terminal Number (Name)
CTR 0 SRC	1 (PFI 0)
CTR 0 GATE	2 (PFI 1)
CTR 0 AUX	1 (PFI 0)
CTR 0 OUT	6 (PFI 4)
CTR 0 A	1 (PFI 0)
CTR 0 Z	3 (PFI 2)
CTR 0 B	2 (PFI 1)
CTR 1 SRC	4 (PFI 3)
CTR 1 GATE	3 (PFI 2)
CTR 1 AUX	4 (PFI 3)
CTR 1 OUT	7 (PFI 5)
CTR 1 A	4 (PFI 3)
CTR 1 Z	2 (PFI 1)
CTR 1 B	3 (PFI 2)
FREQ OUT	8 (PFI 6)



Note For more information about default NI-DAQmx counter inputs, refer to *Connecting Counter Signals* in the *NI-DAQmx Help* or the *LabVIEW Help* in version 8.0 or later.

USB-6212/6216 Screw Terminal

USB-6212/6216 Screw Terminal Pinout

Figure A-3 shows the pinout of the USB-6212 Screw Terminal and USB-6216 Screw Terminal.

For a detailed description of each signal, refer to the *I/O Connector Signal Descriptions* section of Chapter 3, *Connector and LED Information*.

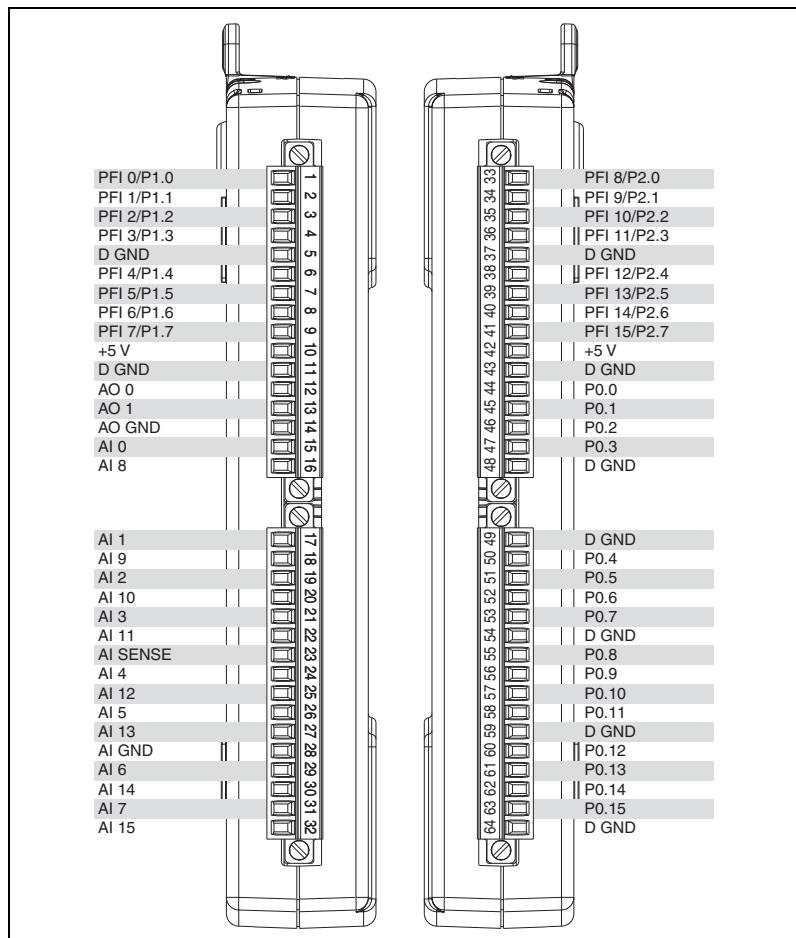

Figure A-3. USB-6212/6216 Screw Terminal Pinout

Table A-3. Default NI-DAQmx Counter/Timer Pins

Counter/Timer Signal	Default Terminal Number (Name)
CTR 0 SRC	33 (PFI 8)
CTR 0 GATE	34 (PFI 9)
CTR 0 AUX	35 (PFI 10)
CTR 0 OUT	38 (PFI 12)
CTR 0 A	33 (PFI 8)
CTR 0 Z	34 (PFI 9)
CTR 0 B	35 (PFI 10)
CTR 1 SRC	4 (PFI 3)
CTR 1 GATE	6 (PFI 4)
CTR 1 AUX	36 (PFI 11)
CTR 1 OUT	39 (PFI 13)
CTR 1 A	4 (PFI 3)
CTR 1 Z	6 (PFI 4)
CTR 1 B	36 (PFI 11)
FREQ OUT	40 (PFI 14)



Note For more information about default NI-DAQmx counter inputs, refer to *Connecting Counter Signals* in the *NI-DAQmx Help* or the *LabVIEW Help* in version 8.0 or later.

USB-6212/6216 Mass Termination

USB-6212/6216 Mass Termination Pinout

Figure A-4 shows the pinout of the USB-6212 Mass Termination and USB-6216 Mass Termination.

For a detailed description of each signal, refer to the *I/O Connector Signal Descriptions* section of Chapter 3, *Connector and LED Information*.

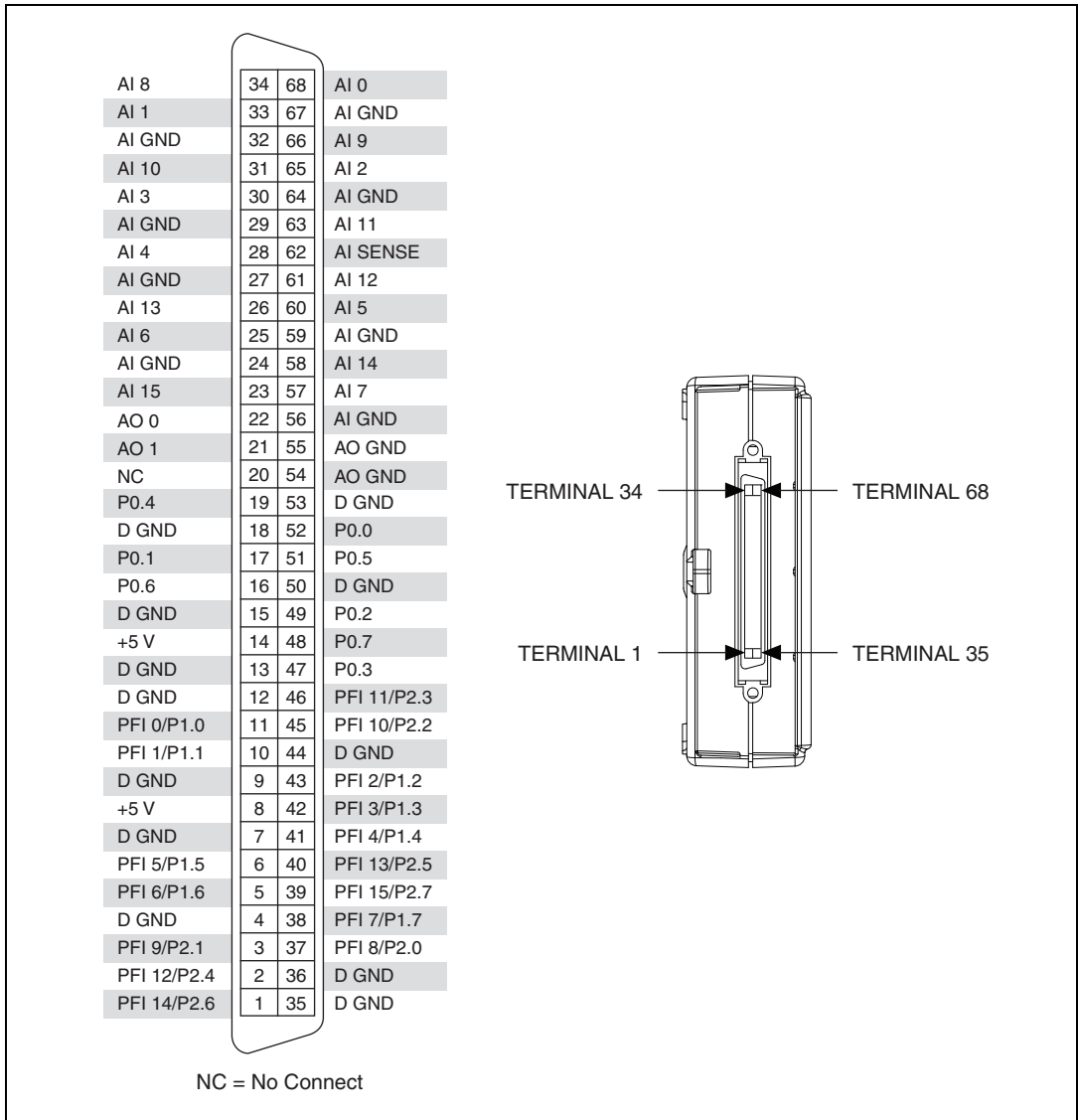

Figure A-4. USB-6212/6216 Mass Termination Pinout

Table A-4. Default NI-DAQmx Counter/Timer Pins

Counter/Timer Signal	Default Terminal Number (Name)
CTR 0 SRC	37 (PFI 8)
CTR 0 GATE	3 (PFI 9)
CTR 0 AUX	45 (PFI 10)
CTR 0 OUT	2 (PFI 12)
CTR 0 A	37 (PFI 8)
CTR 0 Z	3 (PFI 9)
CTR 0 B	45 (PFI 10)
CTR 1 SRC	42 (PFI 3)
CTR 1 GATE	41 (PFI 4)
CTR 1 AUX	46 (PFI 11)
CTR 1 OUT	40 (PFI 13)
CTR 1 A	42 (PFI 3)
CTR 1 Z	41 (PFI 4)
CTR 1 B	46 (PFI 11)
FREQ OUT	1 (PFI 14)



Note For more information about default NI-DAQmx counter inputs, refer to *Connecting Counter Signals* in the *NI-DAQmx Help* or the *LabVIEW Help* in version 8.0 or later.

USB-6212/6216 Mass Termination Cables and Accessories

This section describes some cable and accessory options for USB-6212/6216 Mass Termination devices. Refer to ni.com for other accessory options including new devices.



Caution For compliance with Electromagnetic Compatibility (EMC) requirements, this product must be operated with shielded cables and accessories. If unshielded cables or accessories are used, the EMC specifications are no longer guaranteed unless all unshielded cables and/or accessories are installed in a shielded enclosure with properly designed and shielded input/output ports.

SCC Accessories

SCC provides portable, modular signal conditioning to your DAQ system. To connect your USB-6212/6216 Mass Termination device to an SCC module carrier, such as the SC-2345, SC-2350, or SCC-68, use an SH68-68-EPM shielded cable. The SCC carrier must be externally powered when used with a USB-6212/6216 Mass Termination device. Refer to the [+5 V Power](#) section of Chapter 3, [Connector and LED Information](#), and the [NI USB-621x Specifications](#) for more information.

Refer to the *SCC Configuration Guide*, available by going to ni.com/info and entering the info code `rdscav`, for more information.

BNC Accessories

You can use the SH68-68-EPM shielded cable, to connect the USB-6212/6216 Mass Termination device to BNC accessories, such as the following:

- **BNC-2110**—Provides BNC connectivity to all analog signals, some digital signals, and spring terminals for other digital signals
- **BNC-2111**—Provides BNC connectivity to 16 single-ended analog input signals, two analog output signals, five DIO/PFI signals, and the external reference voltage for analog output
- **BNC-2120**—Similar to the BNC-2110, and also has a built-in function generator, quadrature encoder, temperature reference, and thermocouple connector
- **BNC-2090A**—Desktop/rack-mountable device with 22 BNCs for connecting analog, digital, and timing signals

Screw Terminal Accessories

National Instruments offers several styles of screw terminal connector blocks. Use an SH68-68-EPM shielded cable to connect a USB-6212/6216 Mass Termination device to a connector block, such as the following:

- **CB-68LP and CB-68LPR**—Unshielded connector blocks
- **SCC-68**—I/O connector block with screw terminals, general breadboard area, bus terminals, and four expansion slots for SCC signal conditioning modules
- **SCB-68**—Shielded connector block with temperature sensor
- **TBX-68**—DIN rail-mountable connector block

Cables

In most applications, you can use the following cables:

- **SH68-68-EPM**—High-performance cable with individual bundles separating analog and digital signals. Each differential analog input channel is routed on an individually shielded twisted pair of wires. Analog outputs are also individually shielded
- **R68-68**—Highly-flexible unshielded ribbon cable

Custom Cabling and Connectivity

The CA-1000 is a configurable enclosure that gives user-defined connectivity and flexibility through customized panelettes. Visit ni.com for more information about the CA-1000.

Refer to the [USB-621x Mass Termination Custom Cabling](#) section of Chapter 2, [DAQ System Overview](#), for more information about custom cabling solutions.

USB-6212/6216 BNC

USB-6212/6216 BNC Pinout

Figure A-5 shows the pinout of the USB-6212 BNC and USB-6216 BNC.

For a detailed description of each signal, refer to the *I/O Connector Signal Descriptions* section of Chapter 3, *Connector and LED Information*.

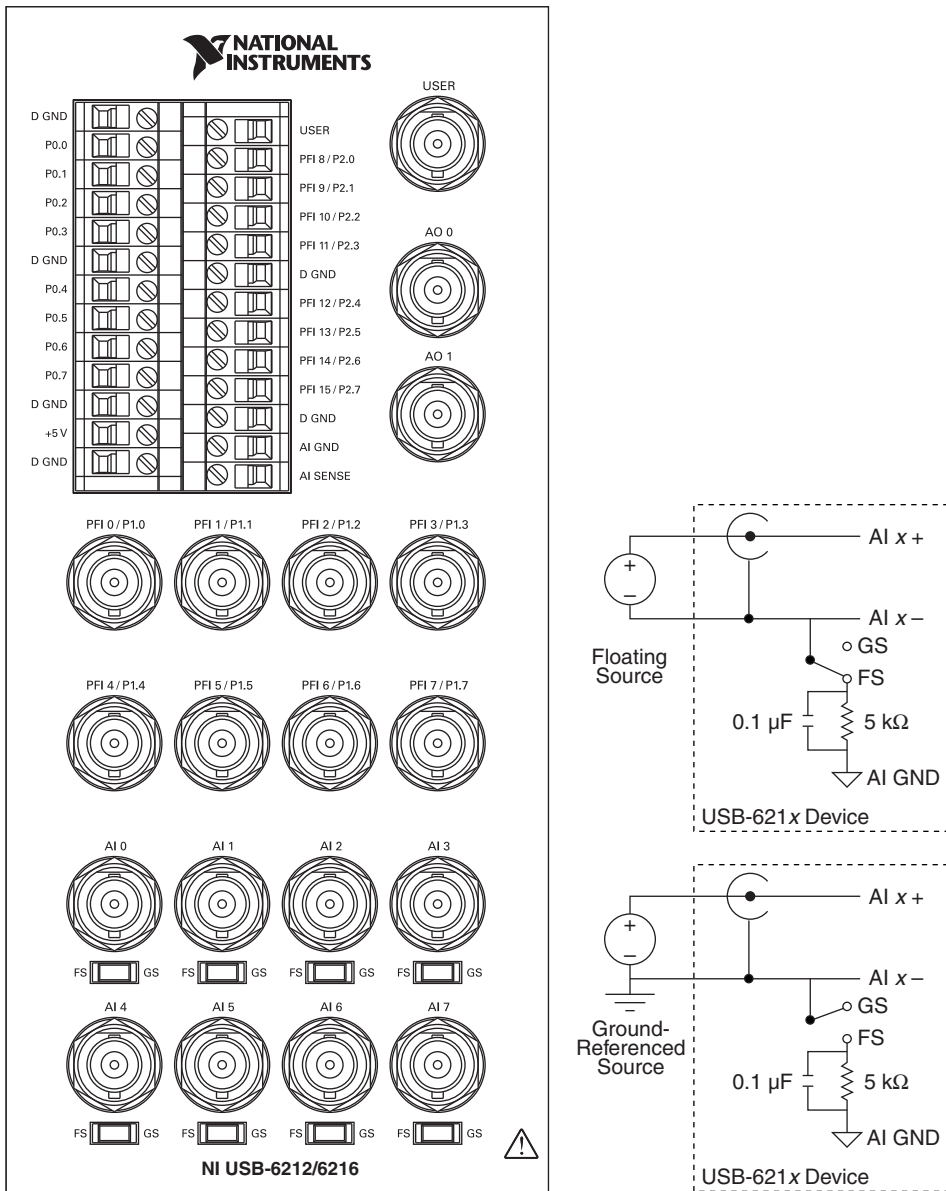

Figure A-5. USB-6212/6216 BNC Top Panel and Pinout

Table A-5. Default NI-DAQmx Counter/Timer Pins

Counter/Timer Signal	Default Terminal Name
CTR 0 SRC	PFI 8
CTR 0 GATE	PFI 9
CTR 0 AUX	PFI 10
CTR 0 OUT	PFI 12
CTR 0 A	PFI 8
CTR 0 Z	PFI 9
CTR 0 B	PFI 10
CTR 1 SRC	PFI 3
CTR 1 GATE	PFI 4
CTR 1 AUX	PFI 11
CTR 1 OUT	PFI 13
CTR 1 A	PFI 3
CTR 1 Z	PFI 4
CTR 1 B	PFI 11
FREQ OUT	PFI 14



Note For more information about default NI-DAQmx counter inputs, refer to *Connecting Counter Signals* in the *NI-DAQmx Help* or the *LabVIEW Help* in version 8.0 or later.

Connecting Signals to the USB-6212/6216 BNC

Analog Input

You can use each analog input BNC connector for one signal in differential mode or two signals in single-ended mode:

- **Differential Mode**—To connect signals in differential mode, determine the type of signal source you are using—a floating signal (FS) source or a ground-referenced signal (GS) source. Refer to the [Connecting Analog Input Signals on USB-6210/6211/6212 Devices](#) or [Connecting Analog Input Signals on USB-6215/6216/6218 Devices](#) section of Chapter 4, *Analog Input*, for more information.

To measure a floating signal source, move the switch to the FS position. To measure a ground-referenced signal source, move the switch to the GS position. Figure A-6 shows the AI 0 BNC and corresponding FS/GS switch on the top panel of the USB-6212/6216 BNC.

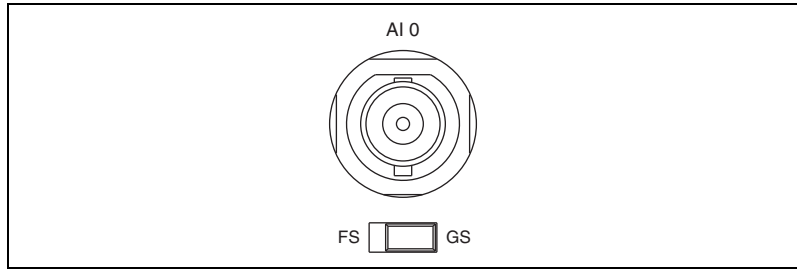

Figure A-6. FS/GS Switch

Figure A-7 shows the analog input circuitry on the USB-6212/6216 BNC. When the switch is set to the FS position, AI $x -$ is grounded through a $0.1 \mu\text{F}$ capacitor in parallel with a $5 \text{ k}\Omega$ resistor.

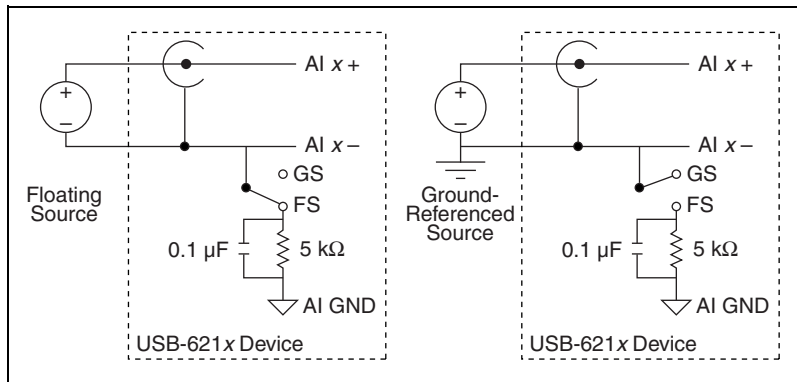

Figure A-7. Analog Input Circuitry

- Single-Ended Mode**—For each BNC connector that you use for two single-ended channels, set the source type switch to the GS position. This setting disconnects the built-in ground reference resistor from the negative terminal of the BNC connector, allowing the connector to be used as a single-ended channel, as shown in Figure A-8.

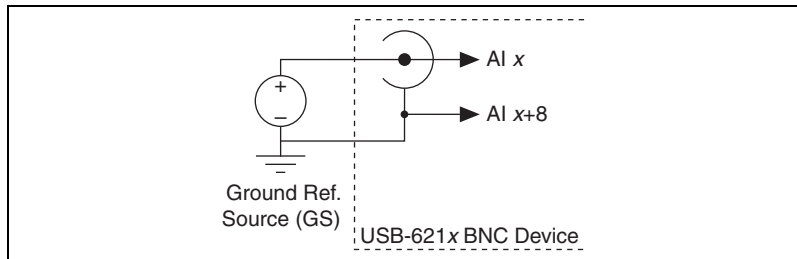

Figure A-8. Single-Ended Channels

When you set the source type to the GS position and configure the device for single-ended input in software, each BNC connector provides access to two single-ended channels, AI x and AI $x+8$. For example, the BNC connector labeled AI 0 provides access to single-ended channels AI 0 and AI 8, the BNC connector labeled AI 1 provides access to single-ended channels AI 1 and AI 9, and so on. Up to 16 single-ended channels are available in single-ended measurement modes.

For information on how to connect your signals in single-ended mode, AI GND, and/or AI SENSE, refer to the [Connecting Analog Input Signals on USB-6210/6211/6212 Devices](#) or [Connecting Analog Input Signals on USB-6215/6216/6218 Devices](#) section of Chapter 4, *Analog Input*. For a detailed description of each signal, refer to the [I/O Connector Signal Descriptions](#) section of Chapter 3, *Connector and LED Information*.

Analog Output

You can access analog output signals on the BNC connectors labeled AO 0 and AO 1. Figure A-9 shows the analog output circuitry on the USB-6212/6216 BNC.

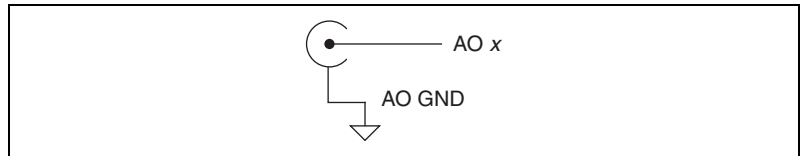

Figure A-9. Analog Output Circuitry

Refer to the [Connecting Analog Output Signals](#) section of Chapter 5, *Analog Output*, for more information.

Digital I/O and Timing I/O

You can access digital I/O and timing I/O signals on the BNC connectors labeled PFI <0..7>/P1.<0..7>. Figure A-10 shows the DIO/TIO circuitry on the USB-6212/6216 BNC.

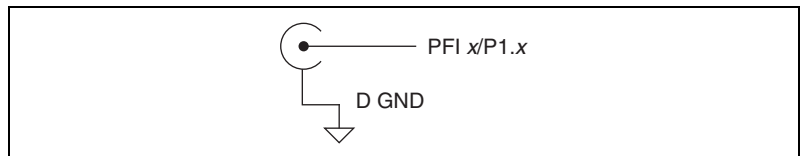

Figure A-10. Digital I/O and Timing I/O Circuitry

Refer to the [Digital I/O on USB-6212/6216 Devices](#) section of Chapter 6, [Digital I/O](#), and the [Connecting PFI Input Signals](#) section of Chapter 7, [PFI](#), for more information.

USER

The USER BNC connector allows you to use a BNC connector for a digital or timing I/O signal of your choice. The USER BNC connector is routed (internal to the USB-6212/6216 BNC) to the USER screw terminal, as shown in Figure A-11.

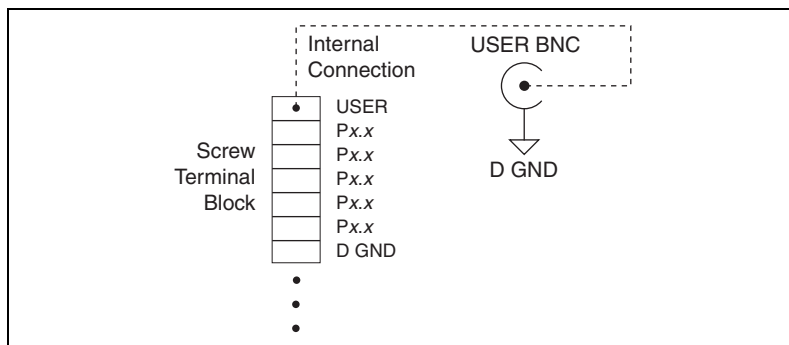

Figure A-11. USER BNC Connection

Figure A-12 shows an example of how to use the USER BNC. To access the PFI 8/P2.0 signal from a BNC, connect USER on the screw terminal block to PFI 8/P2.0 with a wire.

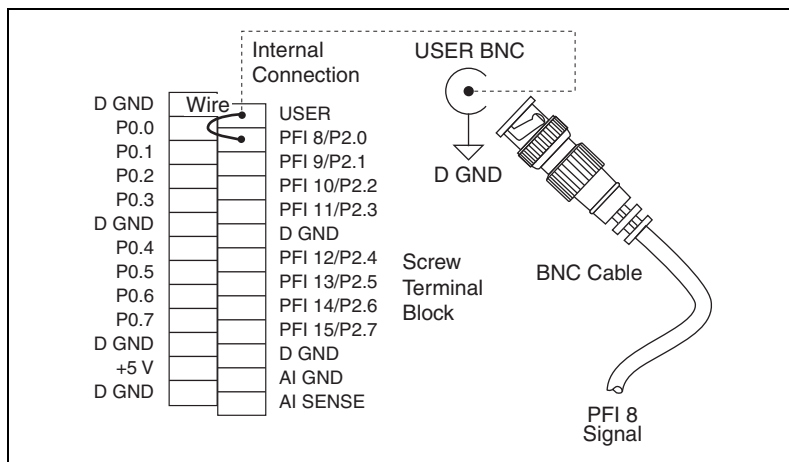

Figure A-12. Connecting PFI 8/P2.0 to USER BNC

USB-6218 Screw Terminal

USB-6218 Screw Terminal Pinout

Figure A-13 shows the pinout of the USB-6218 Screw Terminal.

For a detailed description of each signal, refer to the *I/O Connector Signal Descriptions* section of Chapter 3, *Connector and LED Information*.

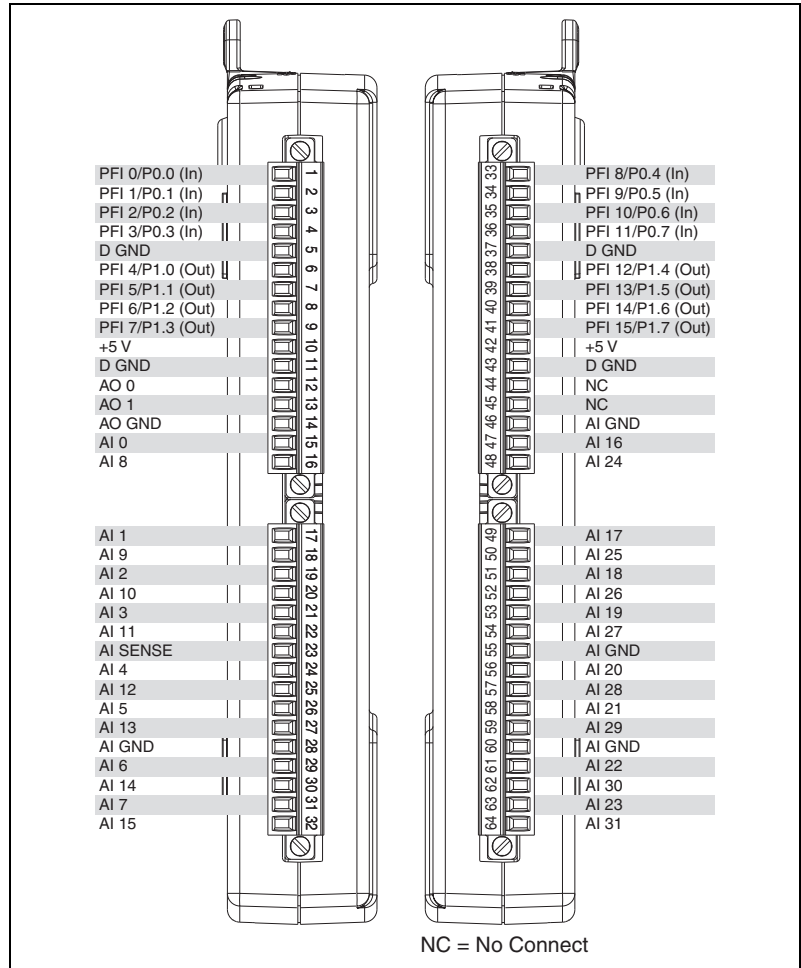

Figure A-13. USB-6218 Screw Terminal Pinout

Table A-6. Default NI-DAQmx Counter/Timer Pins

Counter/Timer Signal	Default Terminal Number (Name)
CTR 0 SRC	1 (PFI 0)
CTR 0 GATE	2 (PFI 1)
CTR 0 AUX	34 (PFI 9)
CTR 0 OUT	6 (PFI 4)
CTR 0 A	1 (PFI 0)
CTR 0 Z	2 (PFI 1)
CTR 0 B	34 (PFI 9)
CTR 1 SRC	4 (PFI 3)
CTR 1 GATE	3 (PFI 2)
CTR 1 AUX	35 (PFI 10)
CTR 1 OUT	7 (PFI 5)
CTR 1 A	4 (PFI 3)
CTR 1 Z	3 (PFI 2)
CTR 1 B	35 (PFI 10)
FREQ OUT	8 (PFI 6)



Note For more information about default NI-DAQmx counter inputs, refer to *Connecting Counter Signals* in the *NI-DAQmx Help* or the *LabVIEW Help* in version 8.0 or later.

USB-6218 BNC

USB-6218 BNC Pinout

Figure A-14 shows the pinout of the USB-6218 BNC.

For a detailed description of each signal, refer to the *I/O Connector Signal Descriptions* section of Chapter 3, *Connector and LED Information*.

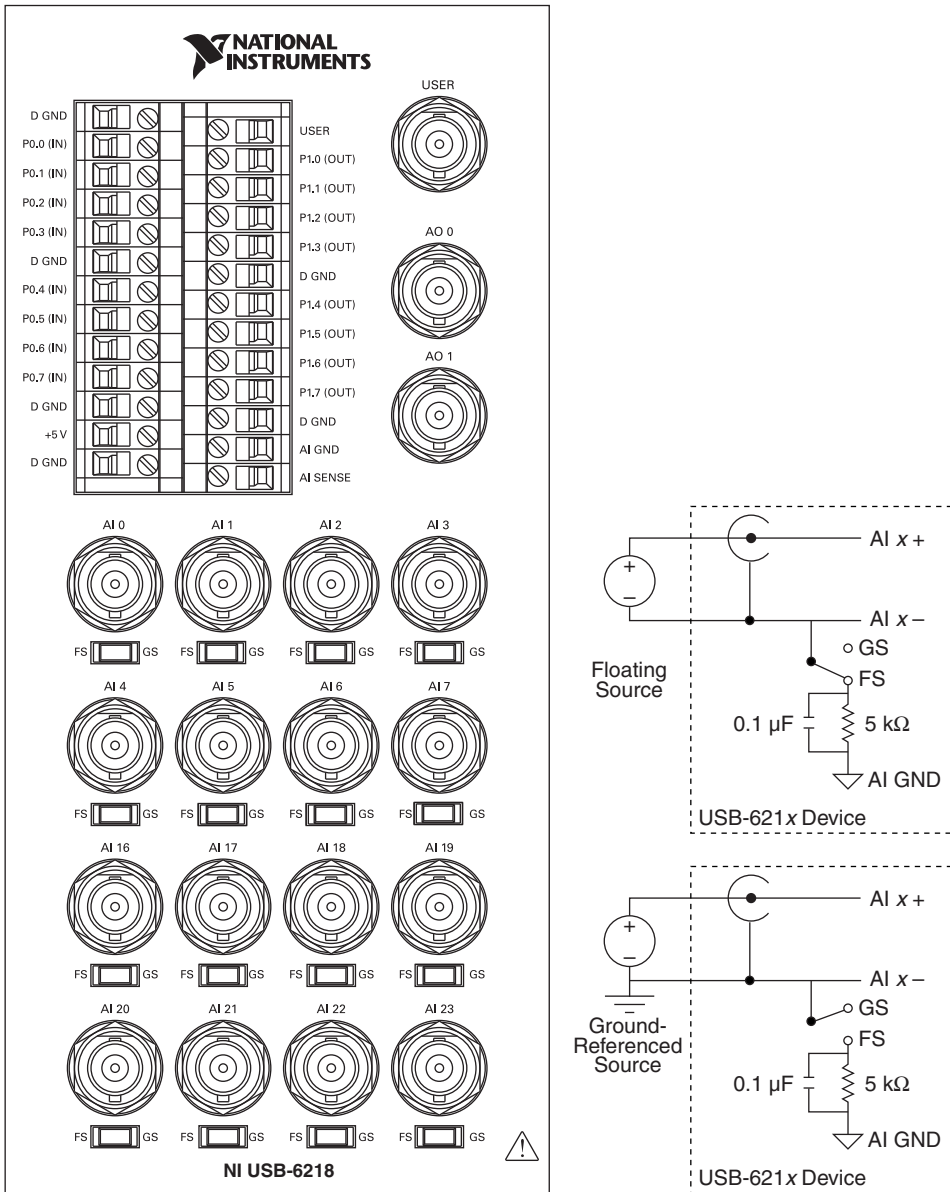

Figure A-14. USB-6218 BNC Top Panel and Pinout

Table A-7. Default NI-DAQmx Counter/Timer Pins

Counter/Timer Signal	Default Terminal Name
CTR 0 SRC	PFI 0
CTR 0 GATE	PFI 1
CTR 0 AUX	PFI 9
CTR 0 OUT	PFI 4
CTR 0 A	PFI 0
CTR 0 Z	PFI 1
CTR 0 B	PFI 9
CTR 1 SRC	PFI 3
CTR 1 GATE	PFI 2
CTR 1 AUX	PFI 10
CTR 1 OUT	PFI 5
CTR 1 A	PFI 3
CTR 1 Z	PFI 2
CTR 1 B	PFI 10
FREQ OUT	PFI 6



Note For more information about default NI-DAQmx counter inputs, refer to *Connecting Counter Signals* in the *NI-DAQmx Help* or the *LabVIEW Help* in version 8.0 or later.

Connecting Signals to the USB-6218 BNC

Analog Input

You can use each analog input BNC connector for one signal in differential mode or two signals in single-ended mode:

- Differential Mode**—To connect signals in differential mode, determine the type of signal source you are using—a floating signal (FS) source or a ground-referenced signal (GS) source. Refer to the [Connecting Analog Input Signals on USB-6215/6216/6218 Devices](#) section of Chapter 4, *Analog Input*, for more information.

To measure a floating signal source, move the switch to the FS position. To measure a ground-referenced signal source, move the switch to the GS position. Figure A-15 shows the AI 0 BNC and corresponding FS/GS switch on the top panel of the USB-6218 BNC.

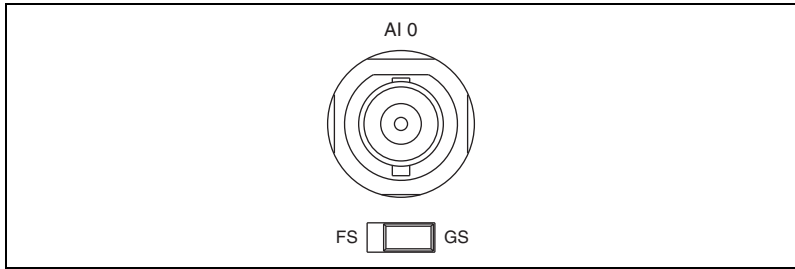

Figure A-15. FS/GS Switch

Figure A-16 shows the analog input circuitry on the USB-6218 BNC. When the switch is set to the FS position, AI x – is grounded through a 0.1 μF capacitor in parallel with a 5 k Ω resistor.

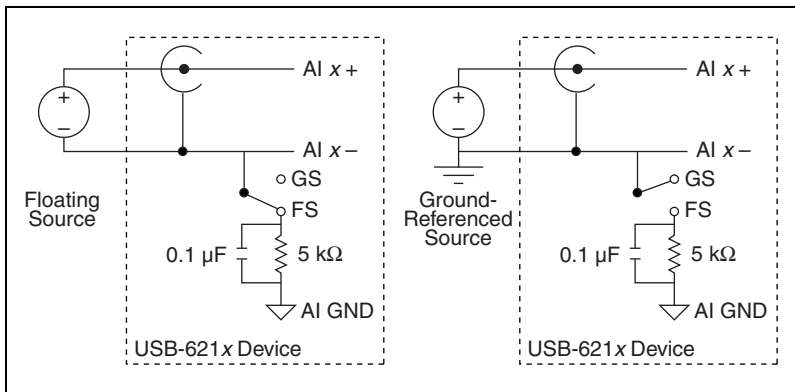

Figure A-16. Analog Input Circuitry

- Single-Ended Mode**—For each BNC connector that you use for two single-ended channels, set the source type switch to the GS position. This setting disconnects the built-in ground reference resistor from the negative terminal of the BNC connector, allowing the connector to be used as a single-ended channel, as shown in Figure A-17.

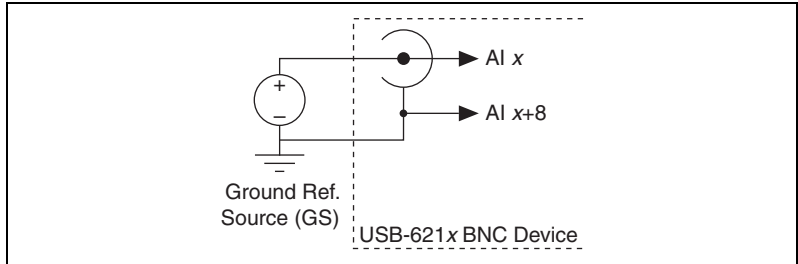

Figure A-17. Single-Ended Channels

When you set the source type to the GS position and configure the device for single-ended input in software, each BNC connector provides access to two single-ended channels, AI x and AI $x+8$. For example, the BNC connector labeled AI 0 provides access to single-ended channels AI 0 and AI 8, the BNC connector labeled AI 1 provides access to single-ended channels AI 1 and AI 9, and so on. Up to 32 single-ended channels are available in single-ended measurement modes.

For information on how to connect your signals in single-ended mode, AI GND, and/or AI SENSE, refer to the [Connecting Analog Input Signals on USB-6215/6216/6218 Devices](#) section of Chapter 4, [Analog Input](#). For a detailed description of each signal, refer to the [I/O Connector Signal Descriptions](#) section of Chapter 3, [Connector and LED Information](#).

Analog Output

You can access analog output signals on the BNC connectors labeled AO 0 and AO 1. Figure A-18 shows the analog output circuitry on the USB-6218 BNC.

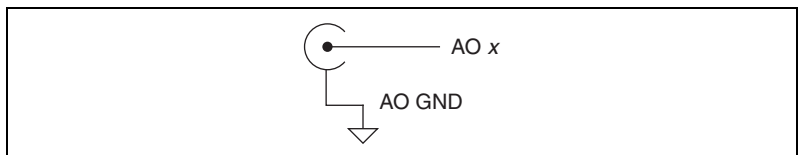

Figure A-18. Analog Output Circuitry

Refer to the [Connecting Analog Output Signals](#) section of Chapter 5, [Analog Output](#), for more information.

USER

The USER BNC connector allows you to use a BNC connector for a digital or timing I/O signal of your choice. The USER BNC connector is routed (internal to the USB-6218 BNC) to the USER screw terminal, as shown in Figure A-19.

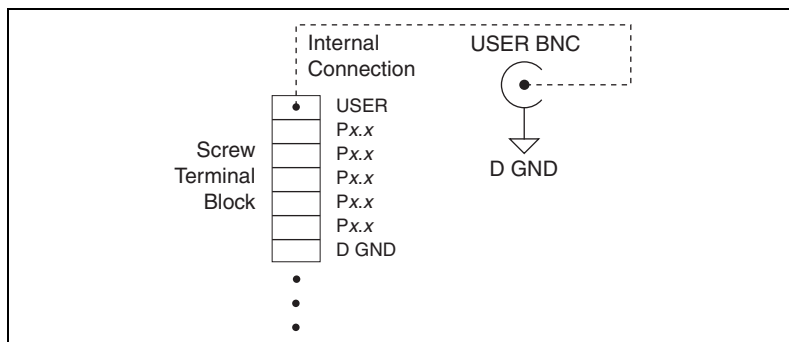

Figure A-19. USER BNC Connection

Figure A-20 shows an example of how to use the USER BNC. To access the PFI 9/P0.5 signal from a BNC, connect USER on the screw terminal block to PFI 9/P0.5 with a wire.

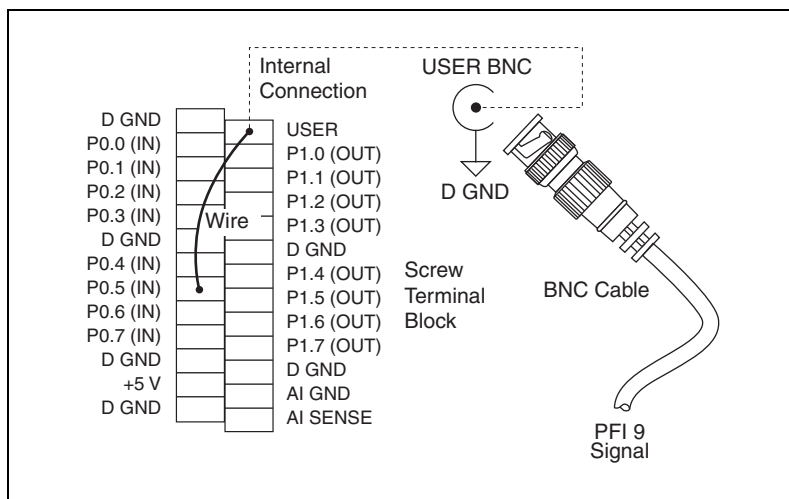

Figure A-20. Connecting PFI 9/P0.5 to USER BNC

Troubleshooting

This section contains common questions about USB-621x devices. If your questions are not answered here, refer to the National Instruments KnowledgeBase at ni.com/kb.

Analog Input

I am seeing crosstalk or ghost voltages when sampling multiple channels. What does this mean?

You may be experiencing a phenomenon called charge injection, which occurs when you sample a series of high-output impedance sources with a multiplexer. Multiplexers contain switches, usually made of switched capacitors. When a channel, for example AI 0, is selected in a multiplexer, those capacitors accumulate charge. When the next channel, for example AI 1, is selected, the accumulated current (or charge) leaks backward through channel 1. If the output impedance of the source connected to AI 1 is high enough, the resulting reading can somewhat affect the voltage in AI 0. To circumvent this problem, use a voltage follower that has operational amplifiers (op-amps) with unity gain for each high-impedance source before connecting to a USB-621x device. Otherwise, you must decrease the sample rate for each channel.

Another common cause of channel crosstalk is due to sampling among multiple channels at various gains. In this situation, the settling times can increase. For more information about charge injection and sampling channels at different gains, refer to the [Multichannel Scanning Considerations](#) section of Chapter 4, [Analog Input](#).

I am using my device in differential analog input ground-reference mode and I have connected a differential input signal, but my readings are random and drift rapidly. What is wrong?

In differential mode, if the readings from the DAQ device are random and drift rapidly, you should check the ground-reference connections. The signal can be referenced to a level that is considered floating with reference to the device ground reference. Even if you are in differential mode, you must still reference the signal to the same ground level as the device

reference. There are various methods of achieving this reference while maintaining a high common-mode rejection ratio (CMRR). These methods are outlined in the [Connecting Analog Input Signals on USB-6210/6211/6212 Devices](#) and [Connecting Analog Input Signals on USB-6215/6216/6218 Devices](#) sections of Chapter 4, *Analog Input*.

AI GND is an AI common signal that routes directly to the ground connection point on the devices. You can use this signal if you need a general analog ground connection point to the device. Refer to the [When to Use Differential Connections with Ground-Referenced Signal Sources](#) section of Chapter 4, *Analog Input*, for more information.

How can I use the AI Sample Clock and AI Convert Clock signals on a USB-621x device to sample the AI channel(s)?

USB-621x devices use AI Sample Clock and AI Convert Clock to perform interval sampling. As Figure B-1 shows, AI Sample Clock controls the sample period, which is determined by the following equation:

$$1/\text{sample period} = \text{sample rate}$$

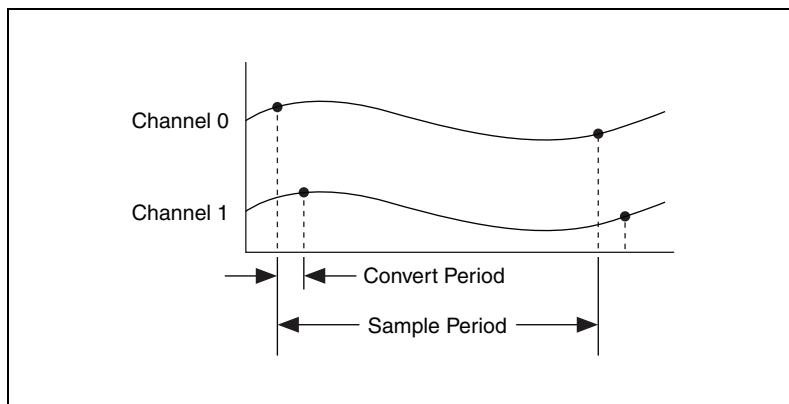

Figure B-1. AI Sample Clock and AI Convert Clock

AI Convert Clock controls the convert period, which is determined by the following equation:

$$1/\text{convert period} = \text{convert rate}$$

This method allows multiple channels to be sampled relatively quickly in relationship to the overall sample rate, providing a nearly simultaneous effect with a fixed delay between channels.

Analog Output

I am seeing glitches on the output signal. How can I minimize it?

When you use a DAC to generate a waveform, you may observe glitches on the output signal. These glitches are normal; when a DAC switches from one voltage to another, it produces glitches due to released charges. The largest glitches occur when the most significant bit of the DAC code changes. You can build a lowpass deglitching filter to remove some of these glitches, depending on the frequency and nature of the output signal. Visit ni.com/support for more information about minimizing glitches.



Technical Support and Professional Services

Visit the following sections of the award-winning National Instruments Web site at ni.com for technical support and professional services:

- **Support**—Technical support at ni.com/support includes the following resources:
 - **Self-Help Technical Resources**—For answers and solutions, visit ni.com/support for software drivers and updates, a searchable KnowledgeBase, product manuals, step-by-step troubleshooting wizards, thousands of example programs, tutorials, application notes, instrument drivers, and so on. Registered users also receive access to the NI Discussion Forums at ni.com/forums. NI Applications Engineers make sure every question submitted online receives an answer.
 - **Standard Service Program Membership**—This program entitles members to direct access to NI Applications Engineers via phone and email for one-to-one technical support as well as exclusive access to on demand training modules via the Services Resource Center. NI offers complementary membership for a full year after purchase, after which you may renew to continue your benefits.

For information about other technical support options in your area, visit ni.com/services, or contact your local office at ni.com/contact.

- **Training and Certification**—Visit ni.com/training for self-paced training, eLearning virtual classrooms, interactive CDs, and Certification program information. You also can register for instructor-led, hands-on courses at locations around the world.
- **System Integration**—If you have time constraints, limited in-house technical resources, or other project challenges, National Instruments Alliance Partner members can help. To learn more, call your local NI office or visit ni.com/alliance.

- **Declaration of Conformity (DoC)**—A DoC is our claim of compliance with the Council of the European Communities using the manufacturer’s declaration of conformity. This system affords the user protection for electromagnetic compatibility (EMC) and product safety. You can obtain the DoC for your product by visiting ni.com/certification.
- **Calibration Certificate**—If your product supports calibration, you can obtain the calibration certificate for your product at ni.com/calibration.

If you searched ni.com and could not find the answers you need, contact your local office or NI corporate headquarters. Phone numbers for our worldwide offices are listed at the front of this manual. You also can visit the Worldwide Offices section of ni.com/niglobal to access the branch office Web sites, which provide up-to-date contact information, support phone numbers, email addresses, and current events.

Glossary

Symbol	Prefix	Value
p	pico	10^{-12}
n	nano	10^{-9}
μ	micro	10^{-6}
m	milli	10^{-3}
k	kilo	10^3
M	mega	10^6

Symbols

%	Percent.
+	Positive of, or plus.
-	Negative of, or minus.
\pm	Plus or minus.
<	Less than.
>	Greater than.
\leq	Less than or equal to.
\geq	Greater than or equal to.
/	Per.
$^{\circ}$	Degree.
Ω	Ohm.

A

A	Amperes—the unit of electric current.
A/D	Analog-to-Digital. Most often used as A/D converter.
AC	Alternating current.
accuracy	A measure of the capability of an instrument or sensor to faithfully indicate the value of the measured signal. This term is not related to resolution; however, the accuracy level can never be better than the resolution of the instrument.
ADE	Application development environment.
analog	A signal whose amplitude can have a continuous range of values.
analog input signal	An input signal that varies smoothly over a continuous range of values, rather than in discrete steps.
analog output signal	An output signal that varies smoothly over a continuous range of values, rather than in discrete steps.
analog trigger	A trigger that occurs at a user-selected point on an incoming analog signal. Triggering can be set to occur at a specific level on either an increasing or a decreasing signal (positive or negative slope). Analog triggering can be implemented either in software or in hardware. When implemented in software (LabVIEW), all data is collected, transferred into system memory, and analyzed for the trigger condition. When analog triggering is implemented in hardware, no data is transferred to system memory until the trigger condition has occurred.
application	A software program that creates an end-user function.
arm	The process of getting an instrument ready to perform a function. For example, the trigger circuitry of a digitizer is armed, meaning that it is ready to start acquiring data when an appropriate trigger condition is met.
ASIC	Application-specific integrated circuit—A proprietary semiconductor component designed and manufactured to perform a set of specific functions for a specific customer.

- asynchronous
1. Hardware—A property of an event that occurs at an arbitrary time, without synchronization to a reference clock.
 2. Software—A property of a function that begins an operation and returns prior to the completion or termination of the operation.

B

- b
- Bit—One binary digit, either 0 or 1.
- B
- Byte—Eight related bits of data, an eight-bit binary number. Also used to denote the amount of memory required to store one byte of data.
- BNC
- Bayonet-Neill-Concelman—A type of coaxial connector used in situations requiring shielded cable for signal connections and/or controlled impedance applications.
- buffer
1. Temporary storage for acquired or generated data.
 2. A memory device that stores intermediate data between two devices.
- bus, buses
- The group of electrical conductors that interconnect individual circuitry in a computer. Typically, a bus is the expansion vehicle to which I/O or other devices are connected. Examples of PC buses are the PCI, AT (ISA), and EISA bus.

C

- C
- Celsius.
- calibration
- The process of determining the accuracy of an instrument. In a formal sense, calibration establishes the relationship of an instrument's measurement to the value provided by a standard. When that relationship is known, the instrument may then be adjusted (calibrated) for best accuracy.
- cascading
- Process of extending the counting range of a counter chip by connecting to the next higher counter.
- CE
- European emissions control standard.

channel	Pin or wire lead to which you apply or from which you read the analog or digital signal. Analog signals can be single-ended or differential. For digital signals, you group channels to form ports. Ports usually consist of either four or eight digital channels.
clock	Hardware component that controls timing for reading from or writing to groups.
CMOS	Complementary metal-oxide semiconductor.
CMRR	Common-mode rejection ratio—A measure of the ability of a differential amplifier to reject interference from a common-mode signal, usually expressed in decibels (dB).
common-mode rejection	The ability of an electronic system to cancel any electronic noise pick-up that is common to both the positive and negative polarities of the input leads to the instrument front end. Common mode rejection is only a relevant specification for systems having a balanced or differential input.
common-mode signal	<ol style="list-style-type: none">1. Any voltage present at the instrumentation amplifier inputs with respect to amplifier ground.2. The signal, relative to the instrument chassis or computer's ground, of the signals from a differential input. This is often a noise signal, such as 50 or 60 Hz hum.
convert rate	Reciprocal of the interchannel delay.
count	The number of events, such as zero crossings, pulses, or cycles.
counter	<ol style="list-style-type: none">1. Software. A memory location used to store a count of certain occurrences.2. Hardware. A circuit that counts events. When it refers to an instrument, it refers to a frequency counter.
counter/timer	A circuit that counts external pulses or clock pulses (timing).

D

DAC	<p>Digital-to-Analog Converter—An electronic device, often an integrated circuit, that converts a digital number into a corresponding analog voltage or current.</p> <p>In the instrumentation world, DACs can be used to generate arbitrary waveform shapes, defined by the software algorithm that computes the digital data pattern, which is fed to the DAC.</p>
DAQ	Data acquisition—The process of collecting and measuring electrical signals from sensors, transducers, and test probes or fixtures and inputting them to a computer for processing.
DAQ-STC2	Data acquisition system timing controller chip.
data acquisition	The general concept of acquiring data, as in begin data acquisition or data acquisition and control. <i>See also</i> DAQ.
data transfer	<p>A technique for moving digital data from one system to another.</p> <p>Options for data transfer are DMA, interrupt, and programmed I/O. For programmed I/O transfers, the CPU in the PC reads data from the DAQ device whenever the CPU receives a software signal to acquire a single data point. Interrupt-based data transfers occur when the DAQ device sends an interrupt to the CPU, telling the CPU to read the acquired data from the DAQ device. DMA transfers use a DMA controller, instead of the CPU, to move acquired data from the device into computer memory. Even though high-speed data transfers can occur with interrupt and programmed I/O transfers, they require the use of the CPU to transfer data. DMA transfers are able to acquire data at high speeds and keep the CPU free for performing other tasks at the same time.</p>
dB	Decibel—The unit for expressing a logarithmic measure of the ratio of two signal levels: $\text{dB} = 20\log_{10} V_1/V_2$, for signals in volts.
DC	Direct current—although the term speaks of current, many different types of DC measurements are made, including DC Voltage, DC current, and DC power.
device	An electronic board that performs general analog or digital I/O functions on one or multiple channels, connected to a PC through a bus or I/O port, such as PCI, PXI, Ethernet, USB, or serial.

differential input	An input circuit that actively responds to the difference between two terminals, rather than the difference between one terminal and ground. Often associated with balanced input circuitry, but also may be used with an unbalanced source.
digital I/O	The capability of an instrument to generate and acquire digital signals. Static digital I/O refers to signals where the values are set and held, or rarely change. Dynamic digital I/O refers to digital systems where the signals are continuously changing, often at multi-MHz clock rates.
digital signal	A representation of information by a set of discrete values according to a prescribed law. These values are represented by numbers.
digital trigger	A TTL level signal having two discrete levels—A high and a low level.
DIO	Digital input/output.
driver	Software unique to the device or type of device, and includes the set of commands the device accepts.

E

edge detection	A technique that locates an edge of an analog signal, such as the edge of a square wave.
EEPROM	Electrically Erasable Programmable Read-Only Memory—ROM that can be erased with an electrical signal and reprogrammed. Some SCXI modules contain an EEPROM to store measurement-correction coefficients.
encoder	A device that converts linear or rotary displacement into digital or pulse signals. The most popular type of encoder is the optical encoder, which uses a rotating disk with alternating opaque areas, a light source, and a photodetector.
external trigger	A voltage pulse from an external source that causes a DAQ operation to begin.

F

FIFO	<p>First-In-First-Out memory buffer—A data buffering technique that functions like a shift register where the oldest values (first in) come out first. Many DAQ products and instruments use FIFOs to buffer digital data from an A/D converter, or to buffer the data before or after bus transmission.</p> <p>The first data stored is the first data sent to the acceptor. FIFOs are often used on DAQ devices to temporarily store incoming or outgoing data until that data can be retrieved or output. For example, an analog input FIFO stores the results of A/D conversions until the data can be retrieved into system memory, a process that requires the servicing of interrupts and often the programming of the DMA controller. This process can take several milliseconds in some cases. During this time, data accumulates in the FIFO for future retrieval. With a larger FIFO, longer latencies can be tolerated. In the case of analog output, a FIFO permits faster update rates, because the waveform data can be stored on the FIFO ahead of time. This again reduces the effect of latencies associated with getting the data from system memory to the DAQ device.</p>
filter	<p>A physical device or digital algorithm that selectively removes noise from a signal, or emphasizes certain frequency ranges and de-emphasizes others. Electronic filters include lowpass, band-pass, and highpass types. Digital filters can operate on numeric data to perform equivalent operations on digitized analog data or to enhance video images.</p>
filtering	<p>A type of signal conditioning that allows you to filter unwanted frequency components from the signal you are trying to measure.</p>
floating signal sources	<p>Signal sources with voltage signals that are not connected to an absolute reference of system ground. Also called non-referenced signal sources. Some common examples of floating signal sources are batteries, transformers, and thermocouples.</p>
frequency	<p>The number of alternating signals that occur per unit time.</p>
ft	<p>Feet.</p>
function	<ol style="list-style-type: none"> <li data-bbox="427 1371 1221 1432">1. A built-in execution element, comparable to an operator, function, or statement in a conventional language. <li data-bbox="427 1449 1221 1512">2. A set of software instructions executed by a single line of code that may have input and/or output parameters and returns a value when executed.

G

glitch	An unwanted signal excursion of short duration that is usually unavoidable.
GND	<i>See</i> ground.
ground	<ol style="list-style-type: none">1. A pin.2. An electrically neutral wire that has the same potential as the surrounding earth. Normally, a noncurrent-carrying circuit intended for safety.3. A common reference point for an electrical system.

H

hardware triggering	A form of triggering where you set the start time of an acquisition and gather data at a known position in time relative to a trigger signal.
Hz	<ol style="list-style-type: none">1. Hertz—The SI unit for measurement of frequency. One hertz (Hz) equals one cycle per second.2. The number of scans read or updates written per second.

I

I/O	Input/Output—The transfer of data to/from a computer system involving communications channels, operator interface devices, and/or data acquisition and control interfaces.
impedance	<ol style="list-style-type: none">1. The electrical characteristic of a circuit expressed in ohms and/or capacitance/inductance.2. Resistance.
in.	Inch or inches.
instrument driver	A set of high-level software functions that controls a specific GPIB, VXI, or RS232 programmable instrument or a specific plug-in DAQ device. Instrument drivers are available in several forms, ranging from a function callable language to a virtual instrument (VI) in LabVIEW.

instrumentation amplifier	A circuit whose output voltage with respect to ground is proportional to the difference between the voltages at its two inputs. An instrumentation amplifier normally has high-impedance differential inputs and high common-mode rejection.
interchannel delay	Amount of time that passes between sampling consecutive channels in an AI scan list. The interchannel delay must be short enough to allow sampling of all the channels in the channel list, within the sample interval. The greater the interchannel delay, the more time the PGIA is allowed to settle before the next channel is sampled. The interchannel delay is regulated by AI Convert Clock.
interface	Connection between one or more of the following: hardware, software, and the user. For example, hardware interfaces connect two other pieces of hardware.
interrupt, interrupt request line	<ol style="list-style-type: none"> 1. A means for a device to notify another device that an event occurred. 2. A computer signal indicating that the CPU should suspend its current task to service a designated activity.
I_{OH}	Current, output high.
I_{OL}	Current, output low.
IRQ	<i>See</i> interrupt, interrupt request line.
L	
LabVIEW	A graphical programming language.
LED	Light-Emitting Diode—A semiconductor light source.
lowpass filter	A filter that passes signals below a cutoff frequency while blocking signals above that frequency.
LSB	Least Significant Bit.

M

m	Meter.
M Series	An architecture for instrumentation-class, multichannel data acquisition devices based on the earlier E Series architecture with added new features.
measurement	The quantitative determination of a physical characteristic. In practice, measurement is the conversion of a physical quantity or observation to a domain where a human being or computer can determine the value.
MIO	Multifunction I/O—DAQ module. Designates a family of data acquisition products that have multiple analog input channels, digital I/O channels, timing, and optionally, analog output channels. An MIO product can be considered a miniature mixed signal tester, due to its broad range of signal types and flexibility. Also known as multifunction DAQ.
module	A board assembly and its associated mechanical parts, front panel, optional shields, and so on. A module contains everything required to occupy one or more slots in a mainframe. SCXI and PXI devices are modules.
monotonicity	A characteristic of a DAC in which the analog output always increases as the values of the digital code input to it increase.
multichannel	Pertaining to a radio-communication system that operates on more than one channel at the same time. The individual channels might contain identical information, or they might contain different signals.
multifunction DAQ	<i>See</i> MIO.
multiplex	To assign more than one signal to a channel. <i>See also</i> mux.
mux	<p>Multiplexer—A set of semiconductor or electromechanical switches arranged to select one of many inputs to a single output. The majority of DAQ cards have a multiplexer on the input, which permits the selection of one of many channels at a time.</p> <p>A switching device with multiple inputs that sequentially connects each of its inputs to its output, typically at high speeds, in order to measure several signals with a single analog input channel.</p>

N

NI-DAQmx	The latest NI-DAQ driver with new VIs, functions, and development tools for controlling measurement devices. The advantages of NI-DAQmx over earlier versions of NI-DAQ include the DAQ Assistant for configuring channels and measurement tasks for your device for use in LabVIEW, LabWindows/CVI, and Measurement Studio; increased performance such as faster single-point analog I/O; and a simpler API for creating DAQ applications using fewer functions and VIs than earlier versions of NI-DAQ.
NI-PGIA	See instrumentation amplifier .
non-referenced signal sources	Signal sources with voltage signals that are not connected to an absolute reference or system ground. Also called floating signal sources. Some common example of non-referenced signal sources are batteries, transformers, or thermocouples.
NRSE	Non-Referenced Single-Ended mode—All measurements are made with respect to a common (NRSE) measurement system reference, but the voltage at this reference can vary with respect to the measurement system ground.

O

offset	The unwanted DC voltage due to amplifier offset voltages added to a signal.
--------	---

P

period	The period of a signal, most often measured from one zero crossing to the next zero crossing of the same slope. The period of a signal is the reciprocal of its frequency (in Hz). Period is designated by the symbol T.
PFI	Programmable Function Interface.
PGIA	Programmable Gain Instrumentation Amplifier.
physical channel	See channel .
posttriggering	The technique used on a DAQ device to acquire a programmed number of samples after trigger conditions are met.

power source	An instrument that provides one or more sources of AC or DC power. Also known as power supply.
ppm	Parts per million.
pretriggering	The technique used on a DAQ device to keep a continuous buffer filled with data, so that when the trigger conditions are met, the sample includes the data leading up to the trigger condition.
pulse	A signal whose amplitude deviates from zero for a short period of time.
pulse width	The time from the rising to the falling slope of a pulse (at 50% amplitude).

Q

quadrature encoder	An encoding technique for a rotating device where two tracks of information are placed on the device, with the signals on the tracks offset by 90° from each other. This makes it possible to detect the direction of the motion.
--------------------	---

R

range	The maximum and minimum parameters between which a sensor, instrument, or device operates with a specified set of characteristics. This may be a voltage range or a frequency range.
real time	<ol style="list-style-type: none">1. Displays as it comes in; no delays.2. A property of an event or system in which data is processed and acted upon as it is acquired instead of being accumulated and processed at a later time.3. Pertaining to the performance of a computation during the actual time that the related physical process transpires so results of the computation can be used in guiding the physical process.
RSE	Referenced Single-Ended mode—All measurements are made with respect to a common reference measurement system or a ground. Also called a grounded measurement system.

S

s	Seconds.
S	Samples.
sample counter	The clock that counts the output of the channel clock, in other words, the number of samples taken. On devices with simultaneous sampling, this counter counts the output of the scan clock and hence the number of scans.
scan	One or more analog or digital input samples. Typically, the number of input samples in a scan is equal to the number of channels in the input group. For example, one pulse from the scan clock produces one scan which acquires one new sample from every analog input channel in the group.
scan interval	Controls how often a scan is initialized; is regulated by the AI Sample Clock signal.
scan rate	Reciprocal of the scan interval.
sensor	A device that responds to a physical stimulus (heat, light, sound, pressure, motion, flow, and so on), and produces a corresponding electrical signal. Primary characteristics of sensors are sensitivity, frequency range, and linearity.
signal conditioning	<ol style="list-style-type: none"> 1. Electronic equipment that makes transducer or other signals suitable in level and range to be transmitted over a distance, or to interface with voltage input instruments. 2. The manipulation of signals to prepare them for digitizing.
signal source	A generic term for any instrument in the family of signal generators.
signals	Signals are waveforms containing information. Although physical signals can be in the form of mechanical, electromagnetic, or other forms, they are most often converted to electronic form for measurement.
single trigger mode	When the arbitrary waveform generator goes through the staging list only once.
single-buffered	Describes a device that acquires a specified number of samples from one or more channels and returns the data when the acquisition is complete.
single-ended input	A circuit that responds to the voltage on one input terminal and ground. <i>See also</i> differential input .

single-ended output	A circuit whose output signal is present between one output terminal and ground.
software triggering	A method of triggering in which you simulate an analog trigger using software. Also called <i>conditional retrieval</i> .
source impedance	A parameter of signal sources that reflects current-driving ability of voltage sources (lower is better) and the voltage-driving ability of current sources (higher is better).
synchronous	<ol style="list-style-type: none"> 1. Hardware—A property of an event that is synchronized to a reference clock. 2. Software—A property of a function that begins an operation and returns only when the operation is complete. A synchronous process is, therefore, <i>locked</i> and no other processes can run during this time.

T

task	In NI-DAQmx, a collection of one or more channels, timing, and triggering and other properties that apply to the task itself. Conceptually, a task represents a measurement or generation you want to perform.
TC	<i>See</i> terminal count.
terminal	An object or region on a node through which data passes.
terminal count	The highest value of a counter.
t_{gh}	Gate hold time.
t_{gsu}	Gate setup time.
t_{gw}	Gate pulse width.
Timebase	The reference signals for controlling the basic accuracy of time or frequency-based measurements. For instruments, timebase refers to the accuracy of the internal clock.
t_{out}	Output delay time.
transducer	A device that responds to a physical stimulus (heat, light, sound, pressure, motion, flow, and so on), and produces a corresponding electrical signal. <i>See also</i> sensor .

trigger

1. Any event that causes or starts some form of data capture.
2. An external stimulus that initiates one or more instrument functions. Trigger stimuli include a front panel button, an external input voltage pulse, or a bus trigger command. The trigger may also be derived from attributes of the actual signal to be acquired, such as the level and slope of the signal.

t_{sc} Source clock period.

t_{sp} Source pulse width.

TTL Transistor-Transistor Logic—A digital circuit composed of bipolar transistors wired in a certain manner. A typical medium-speed digital technology. Nominal TTL logic levels are 0 and 5 V.

U

USB Universal Serial Bus—A 480 Mbit/s serial bus with up to 12-Mbps bandwidth for connecting computers to keyboards, printers, and other peripheral devices. USB 2.0 retains compatibility with the original USB specification.

V

V Volts.

V_{cm} Common-mode voltage.

V_g Ground loop voltage.

V_{IH} Volts, input high.

V_{IL} Volts, input low.

V_{in} Volts in.

V_m Measured voltage.

V_{OH} Volts, output high.

V_{OL} Volts, output low.

V_{out} Volts out.

V_s Signal source voltage.

virtual channel See [channel](#).

W

waveform

1. The plot of the instantaneous amplitude of a signal as a function of time.
2. Multiple voltage readings taken at a specific sampling rate.

Index

Symbols

- +5 V power
 - input, 3-3
 - output, 3-3
 - source, 3-3

Numerics

- 100 kHz Timebase, 10-1
- 20 MHz Timebase, 10-1
- 80 MHz Timebase, 10-1

A

- A/D converter, 4-2
- AC return path, creating, 9-4
- accessories, 2-4
 - USB-6212 Mass Termination, A-10
 - USB-6216 Mass Termination, A-10
- acquisition
 - circular-buffered, 4-9
 - double-buffered, 4-9
 - hardware-timed, 4-9
 - on-demand, 4-8
 - software-timed, 4-8
- ACT LED, 3-6
- ADC, 4-2
- AI Convert Clock signal, 4-16
- AI Convert Clock Timebase signal, 4-19
- AI FIFO, 4-2
- AI Hold Complete Event signal, 4-19
- AI Pause Trigger signal, 4-22
- AI Reference Trigger signal, 4-21
- AI Sample Clock signal, 4-14
- AI Sample Clock Timebase signal, 4-15
- AI Start Trigger signal, 4-20
- ai/ConvertClock, 4-16

- ai/ConvertClockTimebase, 4-19
- ai/HoldCompleteEvent, 4-19
- ai/PauseTrigger, 4-22
- ai/ReferenceTrigger, 4-21
- ai/SampleClock, 4-14
- ai/SampleClockTimebase, 4-15
- ai/StartTrigger, 4-20
- analog input, 4-1
 - channels, sampling with AI Sample Clock and AI Convert Clock, B-2
 - charge injection, B-1
 - circuitry, 4-1
 - connecting signals on
 - USB-6210/6211/6212 devices, 4-23
 - connecting signals on
 - USB-6215/6216/6218 devices, 4-36
 - connecting through I/O connector, 4-1
 - crosstalk when sampling multiple channels, B-1
 - data acquisition methods, 4-8
 - differential, troubleshooting, B-1
 - getting started with applications in software, 4-22
 - ghost voltages when sampling multiple channels, B-1
 - ground-reference settings, 4-1
 - MUX, 4-1
 - sampling channels with AI Sample Clock and AI Convert Clock, B-2
 - signals, 4-11
 - timing signals, 4-11
 - triggering, 4-10
 - troubleshooting, B-1
- analog input signals, 4-11
 - AI Convert Clock, 4-16
 - AI Convert Clock Timebase, 4-19
 - AI Hold Complete Event, 4-19
 - AI Pause Trigger, 4-22

- AI Reference Trigger, 4-21
- AI Sample Clock, 4-14
- AI Sample Clock Timebase, 4-15
- AI Start Trigger, 4-20
- analog output, 5-1
 - circuitry, 5-1
 - connecting signals, 5-4
 - data generation methods, 5-2
 - fundamentals, 5-1
 - getting started with applications in software, 5-10
 - glitches on the output signal, 5-2
 - range, 5-2
 - signals, 5-5
 - timing signals, 5-5
 - trigger signals, 5-4
 - triggering, 5-4
 - troubleshooting, B-3
- analog output signals, 5-5
 - AO Pause Trigger, 5-6
 - AO Sample Clock, 5-8
 - AO Sample Clock Timebase, 5-9
 - AO Start Trigger, 5-5
- analog-to-digital converter, 4-2
- ANSI C documentation, *xvii*
- AO FIFO, 5-1
- AO Pause Trigger signal, 5-6
- AO Sample Clock, 5-2
- AO Sample Clock signal, 5-8
- AO Sample Clock Timebase signal, 5-9
- AO Start Trigger signal, 5-5
- ao/PauseTrigger, 5-6
- ao/SampleClock, 5-8
- ao/StartTrigger, 5-5
- applications
 - counter input, 8-2
 - counter output, 8-21
 - edge counting, 8-2
- applying rubber feet, 1-6
- arm start trigger, 8-33

B

- BNC
 - cables, 2-4
 - connecting signals, A-15, A-23
- board mounting, 1-7
- buffered
 - edge counting, 8-3
 - hardware-timed acquisitions, 4-9
 - hardware-timed generations, 5-3
 - period measurement, 8-7
 - position measurement, 8-18
 - pulse-width measurement, 8-5
 - semi-period measurement, 8-9
 - two-signal edge-separation measurement, 8-20
- bus interface, 11-1

C

- cable management, 1-5
- cables, 2-4
 - custom, 2-4
 - USB-6212 Mass Termination, A-10
 - USB-6216 Mass Termination, A-10
- calibration, 1-2, 2-2
 - certificate (NI resources), C-2
 - circuitry, 2-2
- cascading counters, 8-35
- changing data transfer methods
 - between USB Signal Stream and programmed I/O, 11-2
- channel scanning order, 4-6
- channel Z behavior, 8-17
- channels, sampling with AI Sample Clock and AI Convert Clock, B-2
- charge injection, B-1
- chassis ground, 3-4
- choosing frequency measurement, 8-14
- circular-buffered acquisition, 4-9

- clock
 - generation, 10-1
 - sample, 8-34
- combicon, 2-4
- common-mode noise, 9-3
- configuring AI ground-reference settings in software, 4-5
- connecting
 - analog input signals
 - on USB-6210/6211/6212 devices, 4-23
 - on USB-6215/6216/6218 devices, 4-36
 - analog output signals, 5-4
 - digital I/O signals
 - on USB-6210/6211/6215/6218, 6-3
 - on USB-6212/6216, 6-6
 - floating signal sources, 4-25
 - ground-referenced signal sources, 4-31
 - PFI input signals, 7-4
 - to earth ground, 3-4
- connections
 - for floating signal sources, 4-31
 - single-ended for floating signal sources, 4-31
 - single-ended, referenced configuration, 4-31
- connector
 - information, 3-1
 - labels for USB-621x Screw Terminal, 1-3
 - USB-6210 pinout, A-2
 - USB-6211 pinout, A-4
 - USB-6212 BNC pinout, A-13
 - USB-6212 Mass Termination pinout, A-8
 - USB-6212 Screw Terminal pinout, A-6
 - USB-6215 pinout, A-4
 - USB-6216 BNC pinout, A-13
 - USB-6216 Mass Termination pinout, A-8
 - USB-6216 Screw Terminal pinout, A-6
 - USB-6218 BNC pinout, A-21
 - USB-6218 Screw Terminal pinout, A-19
 - USB-6259 BNC pinout, A-13, A-21
- considerations
 - for field wiring, 4-10
 - for multichannel scanning, 4-5
- continuous pulse train generation, 8-23
- controlling counting direction, 8-2
- conventions used in the manual, *xiii*
- counter input and output, 8-32
- Counter *n* A signal, 8-30
- Counter *n* Aux signal, 8-29
- Counter *n* B signal, 8-30
- Counter *n* Gate signal, 8-29
- Counter *n* HW Arm signal, 8-30
- Counter *n* Internal Output signal, 8-31
- Counter *n* Source signal, 8-28
- Counter *n* TC signal, 8-31
- Counter *n* Up_Down signal, 8-30
- Counter *n* Z signal, 8-30
- counter signals
 - Counter *n* A, 8-30
 - Counter *n* Aux, 8-29
 - Counter *n* B, 8-30
 - Counter *n* Gate, 8-29
 - Counter *n* HW Arm, 8-30
 - Counter *n* Internal Output, 8-31
 - Counter *n* Source, 8-28
 - Counter *n* TC, 8-31
 - Counter *n* Up_Down, 8-30
 - FREQ OUT, 8-31
 - Frequency Output, 8-31
- counters, 8-1
 - cascading, 8-35
 - connecting terminals, 8-32
 - duplicate count prevention, 8-37
 - edge counting, 8-2
 - filters, 8-35
 - generation, 8-21
 - input applications, 8-2
 - other features, 8-34
 - output applications, 8-21

- prescaling, 8-36
 - pulse train generation, 8-23
 - retriggerable single pulse generation, 8-22
 - simple pulse generation, 8-21
 - single pulse generation, 8-21
 - single pulse generation with start trigger, 8-22
 - terminals, default, 8-32
 - timing signals, 8-27
 - triggering, 8-33
 - counting edges, 8-2
 - creating an AC return path, 9-4
 - crosstalk when sampling multiple channels, B-1
 - custom cabling, 2-4
- D**
- DACs, 5-1
 - DAQ
 - hardware, 2-1
 - system, 2-1
 - DAQ-STC2, 2-2
 - data
 - acquisition methods, 4-8
 - generation methods, 5-2
 - transfer methods, 11-1
 - changing, 11-2
 - programmed I/O, 11-1
 - USB Signal Stream, 11-1
 - Declaration of Conformity (NI resources), C-2
 - default
 - counter terminals, 8-32
 - NI-DAQmx counter/timer pins, 8-32
 - pins, 8-32
 - desktop use, 1-6
 - device
 - information, A-1
 - pinouts, 1-2
 - specifications, 1-2, A-1
 - USB-6210, A-2
 - USB-6211, A-4
 - USB-6212 BNC, A-13
 - USB-6212 Mass Termination, A-8
 - USB-6212 Screw Terminal, A-6
 - USB-6215, A-4
 - USB-6216 BNC, A-13
 - USB-6216 Mass Termination, A-8
 - USB-6216 Screw Terminal, A-6
 - USB-6218 BNC, A-21
 - USB-6218 Screw Terminal, A-19
 - diagnostic tools (NI resources), C-1
 - differential connections
 - analog input, troubleshooting, B-1
 - using with floating signal sources, 4-27
 - using with ground-referenced signal sources, 4-34
 - when to use with floating signal sources, 4-25
 - when to use with ground-referenced signal sources, 4-32
 - digital
 - isolation, 9-2
 - isolators, 4-2, 5-2, 9-1
 - routing, 10-1
 - signals, connecting
 - USB-6210/6211/6215/6218, 6-3
 - USB-6212/6216, 6-6
 - source, triggering, 12-1
 - digital I/O
 - triggering, 12-1
 - USB-6210/6211/6215/6218, 6-1
 - block diagram, 6-2
 - circuitry, 6-2
 - connecting signals, 6-3
 - getting started with applications in software, 6-4
 - I/O protection, 6-2
 - static DIO, 6-2

- USB-6212/6216, 6-4
 - block diagram, 6-5
 - circuitry, 6-5
 - connecting signals, 6-6
 - getting started with applications in software, 6-7
 - I/O protection, 6-5
 - programmable power-up states, 6-6
 - static DIO, 6-5
- DIN rail mounting kit, 1-6
- documentation
 - conventions used in manual, *xiii*
 - NI resources, C-1
 - related documentation, *xiv*
- double-buffered acquisition, 4-9
- drivers (NI resources), C-1
- duplicate count prevention, 8-37
 - enabling in NI-DAQmx, 8-39
 - example, 8-37
 - prevention example, 8-38

E

- earth ground, connecting, 3-4
- edge counting, 8-2
 - buffered, 8-3
 - on-demand, 8-2
 - sample clock, 8-3
 - single point, 8-2
- edge-separation measurement
 - buffered two-signal, 8-20
 - single two-signal, 8-20
- enabling duplicate count prevention in NI-DAQmx, 8-39
- encoders, quadrature, 8-16
- encoding
 - X1, 8-16
 - X2, 8-16
 - X4, 8-17
- equivalent time sampling, 8-26

- examples (NI resources), C-1
- exporting timing output signals using PFI terminals, 7-3

F

- features, counter, 8-34
- field wiring considerations, 4-10
- filters
 - counter, 8-35
 - PFI, 7-4
- finite pulse train timing generation, 8-24
- floating signal sources
 - connecting, 4-25
 - description, 4-25
 - using in differential mode, 4-27
 - using in non-referenced single-ended mode, 4-30
 - using in referenced single-ended mode, 4-31
 - when to use in differential mode, 4-25
 - when to use in non-referenced single-ended mode, 4-26
 - when to use in referenced single-ended mode, 4-25
- FREQ OUT signal, 8-31
- frequency
 - division, 8-26
 - generation, 8-25
 - generator, 8-25
 - measurement, 8-10
- Frequency Output signal, 8-31
- front panel
 - USB-6212/6216, A-13
 - USB-6218, A-21
- fuse replacement (USB devices), 3-4

G

- generations
 - analog output data, 5-2
 - buffered hardware-timed, 5-3
 - clock, 10-1
 - continuous pulse train, 8-23
 - frequency, 8-25
 - hardware-timed, 5-2
 - pulse for ETS, 8-26
 - pulse train, 8-23
 - retriggerable single pulse, 8-22
 - simple pulse, 8-21
 - single pulse, 8-21
 - single pulse with start trigger, 8-22
 - software-timed, 5-2
- getting started, 1-1
 - AI applications in software, 4-22
 - AO applications in software, 5-10
 - DIO applications in software
 - USB-6210/6211/6215/6218, 6-4
 - USB-6212/6216, 6-7
- ghost voltages when sampling multiple channels, B-1
- ground-reference
 - connections, checking, B-1
 - settings, 4-1, 4-3
 - analog input, 4-3
- ground-referenced signal sources
 - connecting, 4-31
 - description, 4-31
 - using in differential mode, 4-34
 - using in non-referenced single-ended mode, 4-35
 - when to use in differential mode, 4-32
 - when to use in non-referenced single-ended mode, 4-32
 - when to use in RSE mode, 4-33

H

- hardware, 1-1, 2-1
- hardware-timed
 - acquisitions, 4-9
 - generations, 5-2
- help, technical support, C-1

I

- I/O connector, 3-1
 - USB-6210 pinout, A-2
 - USB-6211 pinout, A-4
 - USB-6212 BNC pinout, A-13
 - USB-6212 Mass Termination pinout, A-8
 - USB-6212 Screw Terminal pinout, A-6
 - USB-6215 pinout, A-4
 - USB-6216 BNC pinout, A-13
 - USB-6216 Mass Termination pinout, A-8
 - USB-6216 Screw Terminal pinout, A-6
 - USB-6218 BNC pinout, A-21
 - USB-6218 Screw Terminal pinout, A-19
- I/O protection, 6-2, 6-5, 7-6
- input signals, using PFI terminals as, 7-2
- insertion of grounded channels between signal channels, 4-7
- installation
 - hardware, 1-1
 - NI-DAQ, 1-1
 - other software, 1-1
- instrument drivers (NI resources), C-1
- instrumentation amplifier, 4-2
- interface, bus, 11-1
- isolated DAQ devices, 9-1
 - benefits, 9-3
 - common-mode noise, 9-3
- isolation barrier, 4-2, 5-2
- isolators, 9-1

K

KnowledgeBase, C-1

L

LabVIEW

documentation, *xv*

Mobile Module 8.x, *xiv*

Touch Panel Module 8.x, *xiv*

LabWindows/CVI documentation, *xvi*

LED, 3-6

Linux, *xiv*

low impedance sources, 4-6

M

Mac OS X, *xiv*

Measurement Studio documentation, *xvi*

measurements

buffered period, 8-7

buffered pulse-width, 8-5

buffered semi-period, 8-9

buffered two-signal edge-separation, 8-20

choosing frequency, 8-14

frequency, 8-10

period, 8-6

position, 8-15

pulse-width, 8-4

semi-period, 8-8

single period, 8-6

single pulse-width, 8-4

single semi-period, 8-8

single two-signal edge-separation, 8-20

two-signal edge-separation, 8-19

using quadrature encoders, 8-16

using two pulse encoders, 8-18

measuring

high frequency with two counters, 8-12

large range of frequencies using two
counters, 8-13

low frequency with one counter, 8-10

averaged, 8-11

methods, data transfer, 11-1

minimizing

glitches on the output signal, 5-2

output signal glitches, B-3

voltage step between adjacent
channels, 4-7

mounting

DIN rail, 1-6

panel, 1-7

multichannel scanning considerations, 4-5

MUX, 4-1

N

National Instruments support and
services, C-1

.NET languages documentation, *xvii*

NI support and services, C-1

NI-DAQmx

default counter terminals, 8-32

documentation, *xiv*

device documentation browser, *xviii*

enabling duplicate count prevention, 8-39

NI-DAQmx Base documentation, *xiv*

NI-PGIA, 4-2

non-referenced single-ended connections

using with floating signal sources, 4-30

using with ground-referenced signal
sources, 4-35

when to use with floating signal
sources, 4-26

when to use with ground-referenced
signal sources, 4-32

O

- on-demand
 - acquisitions, 4-8
 - edge counting, 8-2
 - timing, 4-8
- order of channels for scanning, 4-6
- other software, 1-1
- output signal
 - glitches, B-3
 - minimizing glitches, 5-2
- overview, 2-1

P

- panel mounting, 1-7
- pause trigger, 8-33
- period measurement, 8-6
 - buffered, 8-7
 - single, 8-6
- PFI, 7-1
 - connecting input signals, 7-4
 - exporting timing output signals using PFI terminals, 7-3
 - filters, 7-4
 - I/O protection, 7-6
 - programmable power-up states, 7-6
 - terminals as static digital I/Os, 7-3
 - using terminals as static digital I/Os, 7-3
 - using terminals as timing input signals, 7-2
- pin assignments. *See* pinouts
- pinouts
 - counter default, 8-32
 - device, 1-2
 - USB-6210, A-2
 - USB-6211, A-4
 - USB-6212 BNC, A-13
 - USB-6212 Mass Termination, A-8
 - USB-6212 Screw Terminal, A-6
 - USB-6215, A-4

- USB-6216 BNC, A-13
- USB-6216 Mass Termination, A-8
- USB-6216 Screw Terminal, A-6
- USB-6218 BNC, A-21
- USB-6218 Screw Terminal, A-19
- pins, default, 8-32
- position measurement, 8-15
 - buffered, 8-18
- power, +5 V, 3-3
 - input, 3-3
 - output, 3-3
- power-up states
 - PFI, 7-6
 - USB-6212/6216, 6-6
- prescaling, 8-36
- programmable
 - function interface, 7-1
 - power-up states
 - PFI, 7-6
 - USB-6212/6216, 6-6
- programmed I/O, 11-1
 - changing data transfer methods, 11-2
- programming devices in software, 2-5
- programming examples (NI resources), C-1
- pulse
 - encoders, 8-18
 - generation for ETS, 8-26
 - train generation, 8-23
 - continuous, 8-23
- pulse-width measurement, 8-4
 - buffered, 8-5
 - single, 8-4
- PWR LED, 3-6

Q

- quadrature encoders, 8-16

R

- reciprocal frequency measurement, 8-13
- referenced single-ended configuration, 4-31
- referenced single-ended connections
 - using with floating signal sources, 4-31
 - when to use with floating signal sources, 4-25
 - when to use with ground-referenced signal sources, 4-33
- related documentation, *xiv*
- retriggerable single pulse generation, 8-22
- routing, digital, 10-1
- RSE connections
 - when to use with ground-referenced signal sources, 4-33
- rubber feet, 1-6

S

- sample clock, 8-34
 - edge counting, 8-3
 - measurement, 8-18
- scan speed, 4-8
- scanning speed, 4-8
- self-calibration, 1-2
- semi-period measurement, 8-8
 - buffered, 8-9
 - single, 8-8
- sensors, 2-3
- settings, analog input ground-reference, 4-3
- short high-quality cabling, 4-6
- signal
 - conditioning, 2-3
 - descriptions, 3-1
 - labels for USB-621x Screw Terminal, 1-3
 - sources
 - floating, 4-25
 - ground-referenced, 4-31
- Signal Stream, USB, 11-1

signals

- AI Convert Clock, 4-16
- AI Convert Clock Timebase, 4-19
- AI Hold Complete Event, 4-19
- AI Pause Trigger, 4-22
- AI Reference Trigger, 4-21
- AI Sample Clock, 4-14
- AI Sample Clock Timebase, 4-15
- AI Start Trigger, 4-20
- analog input, 4-11
- analog output, 5-5
- AO Pause Trigger, 5-6
- AO Sample Clock, 5-8
- AO Sample Clock Timebase, 5-9
- AO Start Trigger, 5-5
- connecting analog input
 - on USB-6210/6211/6212 devices, 4-23
 - on USB-6215/6216/6218 devices, 4-36
- connecting analog output, 5-4
- connecting digital I/O
 - on USB-6210/6211/6215/6218, 6-3
 - on USB-6212/6216, 6-6
- connecting PFI input, 7-4
- Counter *n* A, 8-30
- Counter *n* Aux, 8-29
- Counter *n* B, 8-30
- Counter *n* Gate, 8-29
- Counter *n* HW Arm, 8-30
- Counter *n* Internal Output, 8-31
- Counter *n* Source, 8-28
- Counter *n* TC, 8-31
- Counter *n* Up_Down, 8-30
- Counter *n* Z, 8-30
- counters, 8-27
- exporting timing output using PFI terminals, 7-3
- FREQ OUT, 8-31
- Frequency Output, 8-31

- minimizing output glitches, B-3
 - output, minimizing glitches on, 5-2
- simple pulse generation, 8-21
- single
 - period measurement, 8-6
 - point edge counting, 8-2
 - pulse generation, 8-21
 - retriggerable, 8-22
 - with start trigger, 8-22
 - pulse-width measurement, 8-4
 - semi-period measurement, 8-8
 - two-signal edge-separation measurement, 8-20
- single-ended connections
 - for floating signal sources, 4-31
 - referenced single-ended configuration, 4-31
- software
 - configuring AI ground-reference settings, 4-5
 - NI resources, C-1
 - programming devices, 2-5
- software-timed
 - acquisitions, 4-8
 - generations, 5-2
- specifications, A-1
 - device, 1-2
- stacking, 1-6
- start trigger, 8-33
- static DIO
 - USB-6210/6211/6215/6218, 6-2
 - USB-6212/6216, 6-5
 - using PFI terminals as, 7-3
- strain relief, 1-4
- support, technical, C-1
- switching from a large to a small input range, 4-6
- synchronous counting mode, 8-37

T

- technical support, C-1, *xviii*
- terminal configuration, 4-3
 - analog input, 4-1
- terminals
 - connecting counter, 8-32
 - NI-DAQmx default counter, 8-32
- Timebase
 - 100 kHz, 10-1
 - 20 MHz, 10-1
 - 80 MHz, 10-1
- timed acquisitions, 4-8
- timing output signals, exporting using PFI terminals, 7-3
- top panel
 - USB-6212 BNC, A-13
 - USB-6216 BNC, A-13
 - USB-6218 BNC, A-21
- training, *xviii*
- training and certification (NI resources), C-1
- transducers, 2-3
- trigger, 12-1
 - arm start, 8-33
 - pause, 8-33
 - start, 8-33
- triggering, 12-1
 - analog input, 4-10
 - counter, 8-33
 - with a digital source, 12-1
- troubleshooting
 - analog input, B-1
 - analog output, B-3
 - NI resources, C-1
- two-signal edge-separation measurement, 8-19
 - buffered, 8-20
 - single, 8-20

U**USB**

- bulk transfers, 11-1
- cable strain relief, 1-4, 1-8
- chassis ground, 3-4
- Signal Stream, 11-1
- USB Signal Stream
 - as a transfer method, 11-1
 - changing data transfer methods, 11-2
- USB-6210, A-2
 - analog input signals, 4-23
 - default counter/timer pins, A-3
 - digital I/O, 6-1
 - pinout, A-2
- USB-6211, A-4
 - analog input signals, 4-23
 - default counter/timer pins, A-5
 - digital I/O, 6-1
 - pinout, A-4
- USB-6212 BNC, A-13
 - analog input signals, 4-23
 - chassis ground, 3-4
 - connecting signals, A-15
 - default counter/timer pins, A-15
 - digital I/O, 6-4
 - pinout, A-13
- USB-6212 Mass Termination, A-8
 - accessories, A-10
 - analog input signals, 4-23
 - cables, A-10
 - default counter/timer pins, A-10
 - digital I/O, 6-4
 - pinout, A-8
- USB-6212 Screw Terminal, A-6
 - analog input signals, 4-23
 - default counter/timer pins, A-7
 - digital I/O, 6-4
 - pinout, A-6
- USB-6215, A-4
 - analog input signals, 4-36
 - default counter/timer pins, A-5
 - digital I/O, 6-1
 - pinout, A-4
- USB-6216 BNC, A-13
 - analog input signals, 4-23
 - chassis ground, 3-4
 - connecting signals, A-15
 - default counter/timer pins, A-15
 - digital I/O, 6-4
 - pinout, A-13
- USB-6216 Mass Termination, A-8
 - accessories, A-10
 - analog input signals, 4-36
 - cables, A-10
 - default counter/timer pins, A-10
 - digital I/O, 6-4
 - pinout, A-8
- USB-6216 Screw Terminal, A-6
 - analog input signals, 4-36
 - default counter/timer pins, A-7
 - digital I/O, 6-4
 - pinout, A-6
- USB-6218 BNC, A-21
 - analog input signals, 4-36
 - chassis ground, 3-4
 - connecting signals, A-23
 - digital I/O, 6-1
 - pinout, A-21
- USB-6218 Screw Terminal, A-19
 - analog input signals, 4-36
 - default counter/timer pins, A-20, A-23
 - digital I/O, 6-1
 - pinout, A-19
- USB-621x
 - cable management, 1-5
 - cables and accessories, 2-4
 - cabling, 2-4
 - chassis ground, 3-4

- combicon, 2-4
- desktop use, 1-6
- device security, 1-8
- DIN rail mounting kit, 1-6
- fuse replacement, 3-4
- information, A-1
- labeling, 1-3
- LED, 3-6
- panel mounting, 1-7
- signal labels, 1-3
- signal wire management, 1-5
- specifications, *xviii*
- stacking, 1-6
 - USB cable strain relief, 1-4
- using low impedance sources, 4-6
- using PFI terminals
 - as static digital I/Os, 7-3
 - as timing input signals, 7-2
 - to export timing output signals, 7-3
- using short high-quality cabling, 4-6

W

- waveform generation signals, 5-5
- Web resources, C-1

X

- X1 encoding, 8-16
- X2 encoding, 8-16
- X4 encoding, 8-17